



Dormer & 3-Story Zoning Amendment

Land Use Committee - 4/17/2025

The Problem

- Current dormer rules are onerous, expensive, and less energy efficient
- Current rules are not in keeping with existing dormers throughout the city
- Current rules limit how much living space we can add to the city

Our amendment lifts all of these restrictions and simplifies the zoning rules

Current Zoning

k. Gable Dormer

- i. A gable dormer is a window space with a GABLE, HIP, or arched roof that projects perpendicularly from a pitched roof. Dormer windows provide light to the HABITABLE space of a half-STORY.

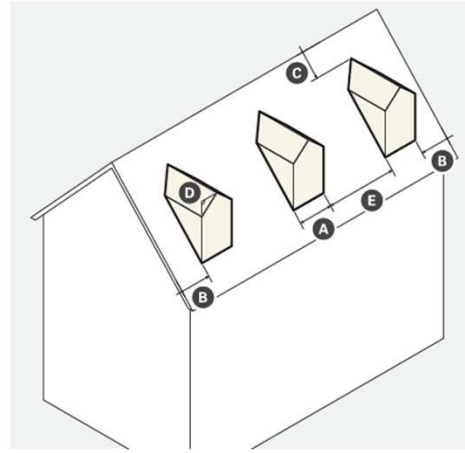

Dimensions	
A Face Width (max)	window(s) width +18 in
Side Wall SETBACK (min)	--
Roof with eave	0 ft
Roof without eave	1 ft
B Facade & Rear Wall SETBACK (min)	3 ft
C Ridge SETBACK (min)	1 ft
D Dormer Separation (min)	50% of width

- ii. Standards
 - a). The face wall of a gable dormer may not project beyond the exterior wall of the BUILDING and may not interrupt the eave of the roof.
 - b). Gable dormers may be combined with a shed dormer(s) to create a Nantucket dormer.
 - c). The cumulative width of a single, multiple, or attached combinations of dormers may equal up to fifty percent (50%) of the eave/ridge length of the roof.
 - d). Flat roofs are prohibited.

l. Shed Dormer

- i. A shed dormer is window space with a shed roof that projects perpendicularly from a pitched roof. Shed dormers provide light and additional HABITABLE space to a half-STORY.

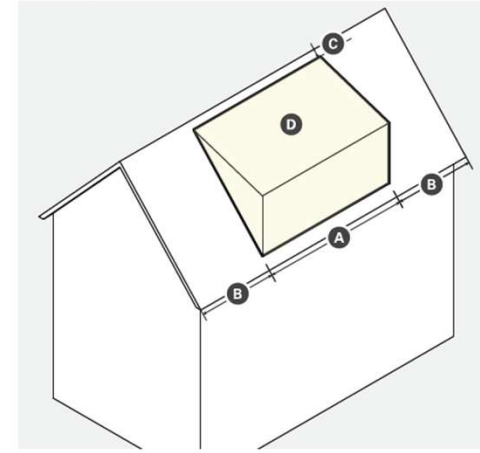

Dimensions	
A Face Width (max)	window(s) width +36 in
Side Wall SETBACK (min)	--
Roof with eave	0 ft
Roof without eave	1 ft
B Facade & Rear Wall SETBACK (min)	3 ft
C Ridge SETBACK (min)	1 ft
Dormer Separation (min)	50% of width

- ii. Standards
 - a). The face wall of a shed dormer may not project beyond the exterior wall of the BUILDING and may not interrupt the eave of the roof.
 - b). Shed dormers may be combined with a dormer window(s) to create a Nantucket dormer.
 - c). The cumulative width of a single, multiple, or attached combinations of dormers may equal up to fifty percent (50%) of the eave/ridge length of the roof.
 - d). Flat roofs are prohibited.

Face Width

- Requires dormers to be mostly windows
- Decreases energy efficiency
- Causes strange window configurations
 - Meeting the letter of the rule, but probably not the spirit
- Makes it harder to partition the new space
 - Why have a bank of windows if you expect a bed against the wall?
- Adds significant cost
 - Windows are expensive, especially efficient ones
 - Framing has to be more complex to carry snow loads
- Doesn't match every other floor
 - Zoning requires all floors to have 15% fenestration, which is what we propose for dormers

Dimensions		Dimensions	
A Face Width (max)	window(s) width +18 in	A Face Width (max)	window(s) width +36 in
Side Wall SETBACK (min)	--	Side Wall SETBACK (min)	--
Roof with eave	0 ft	Roof with eave	0 ft
Roof without eave	1 ft	Roof without eave	1 ft
B Facade & Rear Wall SETBACK (min)	3 ft	B Facade & Rear Wall SETBACK (min)	3 ft
C Ridge SETBACK (min)	1 ft	C Ridge SETBACK (min)	1 ft
D Dormer Separation (min)	50% of width	Dormer Separation (min)	50% of width

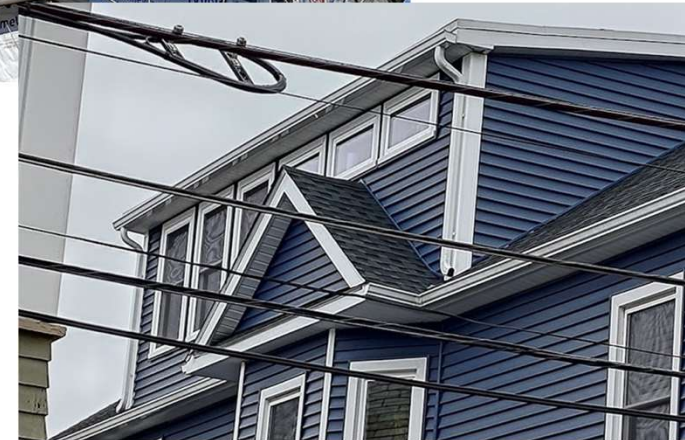

Non-Conforming Examples



Setbacks

- Purely aesthetic restrictions
 - That don't match existing dormers
- Limit flexibility for our older housing stock
 - 3ft can be the difference between a bedroom and a large closet
- More expensive to build
 - Ridge setbacks require complex framing to handle snow loads

Dimensions		Dimensions	
A Face Width (max)	window(s) width +18 in	A Face Width (max)	window(s) width +36 in
Side Wall SETBACK (min)	--	Side Wall SETBACK (min)	--
Roof with eave	0 ft	Roof with eave	0 ft
Roof without eave	1 ft	Roof without eave	1 ft
B Facade & Rear Wall SETBACK (min)	3 ft	B Facade & Rear Wall SETBACK (min)	3 ft
C Ridge SETBACK (min)	1 ft	C Ridge SETBACK (min)	1 ft
D Dormer Separation (min)	50% of width	D Dormer Separation (min)	50% of width



More Non-Conforming Examples



Cumulative Width

- Allows half of each side of the roof to be a dormer
- Greatly limits flexibility
- Many existing dormers are larger
- Doesn't allow for a full dormer on any side
 - Many homes have these
 - Some even have them on both sides

<p>ii. Standards</p> <p>a). The face wall of a gable dormer may not project beyond the exterior wall of the BUILDING and may not interrupt the eave of the roof.</p> <p>b). Gable dormers may be combined with a shed dormer(s) to create a Nantucket dormer.</p> <p>c). The cumulative width of a single, multiple, or attached combinations of dormers may equal up to fifty percent (50%) of the eave/ridge length of the roof.</p> <p>d). Flat roofs are prohibited.</p>	<p>ii. Standards</p> <p>a). The face wall of a shed dormer may not project beyond the exterior wall of the BUILDING and may not interrupt the eave of the roof.</p> <p>b). Shed dormers may be combined with a dormer window(s) to create a Nantucket dormer.</p> <p>c). The cumulative width of a single, multiple, or attached combinations of dormers may equal up to fifty percent (50%) of the eave/ridge length of the roof.</p> <p>d). Flat roofs are prohibited.</p>
--	--



Full Width Examples

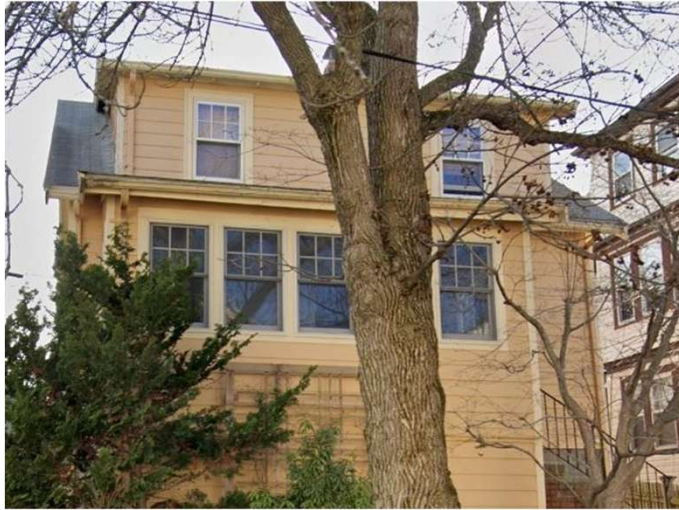

Full Width Examples



Aesthetic Restrictions

- Interrupting the eave
 - Purely aesthetic restriction
- Flat roofs (2:12 roof slope)
 - Limits indoor space on low-ceiling attics
- Goal: Prohibit 3-story houses (even though we now allow 3-story triple-deckers)

A non-conforming example of interrupting the eave

ii. Standards	ii. Standards
a). The face wall of a gable dormer may not project beyond the exterior wall of the BUILDING and may not interrupt the eave of the roof.	a). The face wall of a shed dormer may not project beyond the exterior wall of the BUILDING and may not interrupt the eave of the roof.
b). Gable dormers may be combined with a shed dormer(s) to create a Nantucket dormer.	b). Shed dormers may be combined with a dormer window(s) to create a Nantucket dormer.
c). The cumulative width of a single, multiple, or attached combinations of dormers may equal up to fifty percent (50%) of the eave/ridge length of the roof.	c). The cumulative width of a single, multiple, or attached combinations of dormers may equal up to fifty percent (50%) of the eave/ridge length of the roof.
d). Flat roofs are prohibited.	d). Flat roofs are prohibited.



Example - Jeff Byrnes

- Initially built matching older dormers
- Required to add ridge setback and eaveline continuation post-construction
 - “Face Width” requirement waived by variance



Our Amendment

- 15% Fenestration instead of “Face Width”
 - In-line with all other levels of buildings
- Remove setback minimums and cumulative width maximums
 - Let building code and house type dictate any needed restrictions
 - Let people build what works for their home
- Remove minor aesthetic restrictions
- Allow 3 stories on all NR homes
 - Match house & triple-decker building types
 - Allows easier accessibility (like elevators)
 - Brings other building types in-line with recently legalized triple deckers

k. Gable Dormer

- i. A gable dormer is a space with a GABLE, HIP, or arched roof that projects perpendicularly from a pitched roof. Gable dormers provide light and additional HABITABLE space to a half-story.

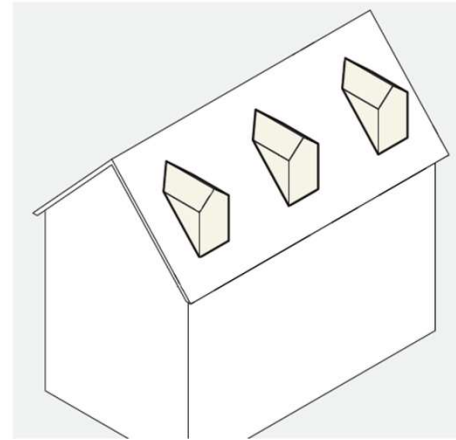

Dimensions	
Dormer Fenestration (min, cumulative)	15%

- ii. Standards
 - a). The face wall of a gable dormer may not project beyond the exterior wall of the building.
 - b). Gable dormers may be combined with a shed dormer(s) to create a Nantucket dormer.

l. Shed Dormer

- i. A shed dormer is a space with a shed roof that projects perpendicularly from a pitched roof. Shed dormers provide light and additional HABITABLE space to a half-story.

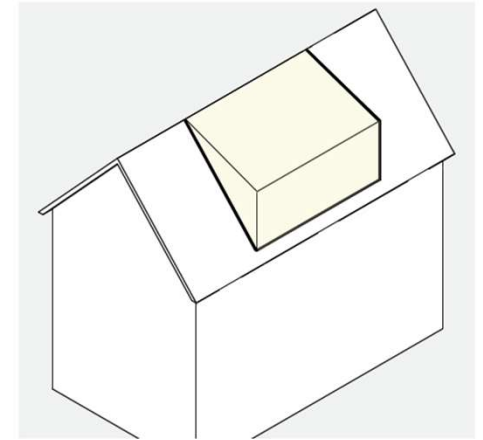

Dimensions	
Dormer Fenestration (min, cumulative)	15%

- ii. Standards
 - a). The face wall of a shed dormer may not project beyond the exterior wall of the building.
 - b). Shed dormers may be combined with a gable dormer(s) to create a Nantucket dormer.
 - c). Full-width shed dormers are permitted.

Benefits

- More flexibility with less cost
 - People can expand their homes upward in a way that fits their needs more easily
- Less strain on city resources
 - Fewer projects will need drawn-out ZBA hearings, freeing city staff
- Meets climate goals
 - Fewer mandatory windows allows more insulation and efficiency
- Meets housing goals
 - More space to help growing families stay in their homes
 - More bedrooms for tenants to live in

k. Gable Dormer

- i. A gable dormer is a space with a GABLE, HIP, or arched roof that projects perpendicularly from a pitched roof. Gable dormers provide light and additional HABITABLE space to a half-story.

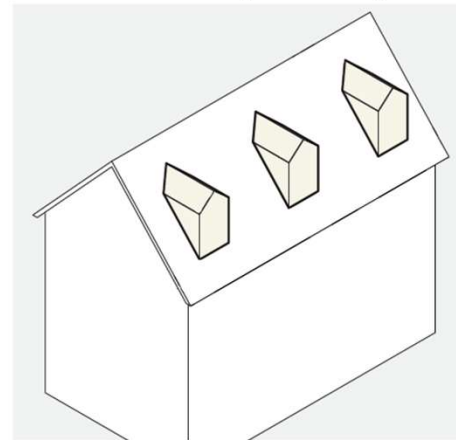

Dimensions	
Dormer Fenestration (min, cumulative)	15%

- ii. Standards
 - a). The face wall of a gable dormer may not project beyond the exterior wall of the building.
 - b). Gable dormers may be combined with a shed dormer(s) to create a Nantucket dormer.

l. Shed Dormer

- i. A shed dormer is a space with a shed roof that projects perpendicularly from a pitched roof. Shed dormers provide light and additional HABITABLE space to a half-story.

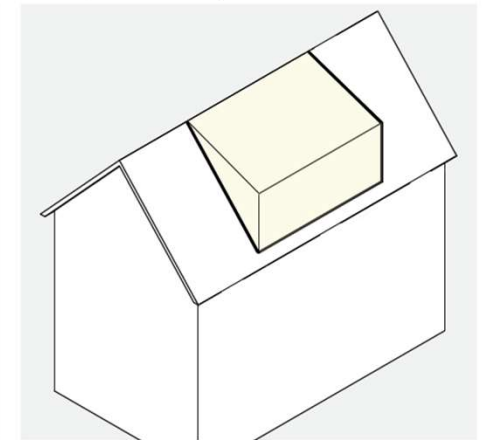

Dimensions	
Dormer Fenestration (min, cumulative)	15%

- ii. Standards
 - a). The face wall of a shed dormer may not project beyond the exterior wall of the building.
 - b). Shed dormers may be combined with a gable dormer(s) to create a Nantucket dormer.
 - c). Full-width shed dormers are permitted.