

6.5 RESEARCH & DEVELOPMENT (R&D)

6.5.1 Description

The Research & Development district is characterized by large floor plate buildings up to four (4) stories in height. The district is entirely commercial with a concentration of business incubator and scientific research & development principal uses with supporting businesses located to encourage communal community development. Forecourts, courtyards, multi-use alleys, and multi-purpose shared spaces are common.

6.5.2 Intent

- a. To implement the objectives of the Comprehensive Plan of the City of Somerville for commercial development.
- b. To create, maintain, and enhance areas appropriate for moderately scaled single- and multi-use commercial buildings; neighborhood-, community-serving uses; and employment opportunities in the scientific research sector.

6.5.3 Purpose

- a. To permit the development of single- and multi-use commercial buildings that do not exceed four (4) stories in height.
- b. To provide quality commercial spaces and permit a mix of uses common to the scientific research & development economy and supporting commercial activities.
- c. To prohibit residential principal uses.

6.5.4 Applicability

- a. The section is applicable to all real property within the Research & Development district as shown on maps of the Official Zoning Atlas of the City of Somerville.

6.5.5 Development Review

- a. Development review is subject to the provisions of Article 15: Administration of this Ordinance.
- b. This Ordinance may also require Subdivision Plan Approval, Site Plan Approval, a Special Permit, or a Hardship Variance based on the nature of a development proposal. In such cases, additional development review is required in accordance with Article 15: Administration.
 - i. The Planning Board is the decision-making authority for all development that requires Site Plan Approval or a Special Permit.
 - ii. The Zoning Board of Appeals is the Review Board for all Hardship Variances.

6.5.6 Building Types

- a. One (1) principal building is permitted on each lot.
- b. The following principal building types are permitted by Site Plan Approval in the Research & Development district:
 - i. Commercial Building
- c. Accessory structures are regulated according to Article 10: Development Standards of this Ordinance.

6.5.7 Commercial Building

A large floor plate, single- to multi-story principal building type purpose built for occupation by commercial uses. Buildings typically provide high bay ceilings and open floor plans that can be customized to meet the specific business needs of tenants. Ground story commercial space may include permitted uses from the arts & creative enterprise, civic or institutional, commercial service, or food & beverage service use categories. Floor space of upper stories is typically occupied by permitted uses from the office use category.

The following images are examples of the commercial building type and are intended only for illustrative purposes.



a. Lot Standards

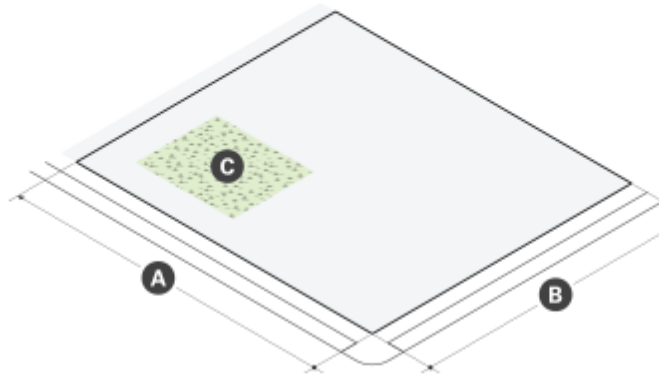

Lot Dimensions	
A Lot Width (min)	30 ft

Lot Development	
Lot Coverage (max)	100%
Green Score (min)	0.20

b. Building Placement

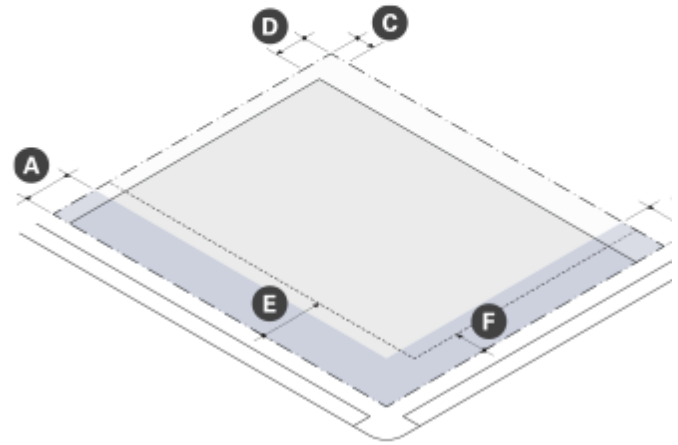

Building Setbacks	
Curb Setback (min)	12 ft
A Primary Front Setback (min/max)	2 ft 15 ft
B Secondary Front Setback (min/max)	2 ft 15 ft
C Side Setback (min)	0 ft
Abutting an Alley or R-ROW	0 ft
Abutting any non-NR or -LHD	0 ft
1 st – 3 rd Story Abutting NR or LHD	10 ft
4 th Story Abutting NR or LHD	30 ft
D Rear Setback (min)	–
Abutting an Alley or R-ROW	0 ft
Abutting any non-NR or -LHD	10 ft
1 st – 3 rd Story Abutting NR or LHD	20 ft
4 th Story Abutting NR or LHD	30 ft

Parking Setbacks	
E Primary Front Setback (min)	–
Surface Parking	20 ft
Structured Parking	20 ft
F Secondary Front Setback (min)	–
Surface Parking	10 ft
Structured Parking	2 ft

c. Massing & Height

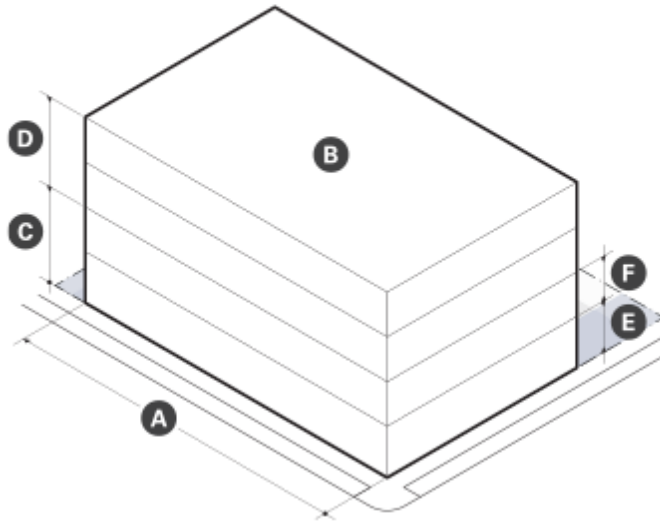

d. Uses & Features

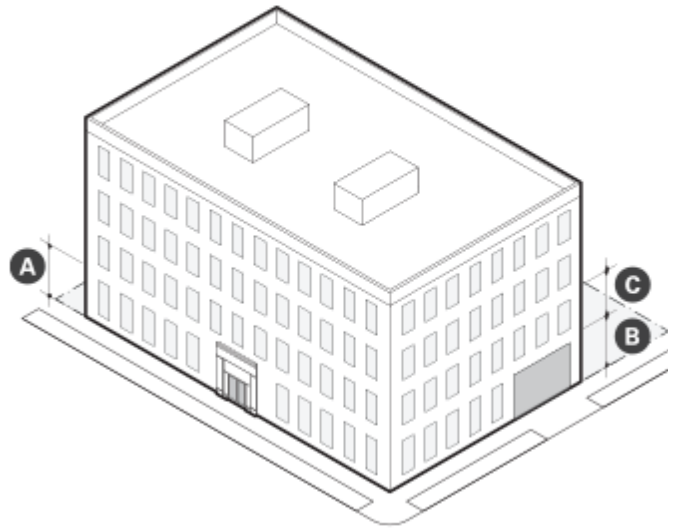

Main Mass	
A Building Width (max)	n/a
Facade Build Out (min)	–
Primary Front (min)	65%
Secondary Front (min)	65%
B Floor Plate (max)	45,000 sf
C Ground Story Height (min)	15 ft
D Upper Story Height (min)	10 ft
E Number of Stories (min/max)	2 4
F Building Height, Feet (max)	78 ft
Roof Type	Flat

Facade Composition	
Ground Story Fenestration	–
A Primary Facade (min)	50%
B Secondary Facade (min/max)	15%
C Upper Story Fenestration (min/max)	15% 70%
Blank Wall (max)	50 ft

Use & Occupancy	
Ground Story Entrance Spacing (max)	n/a
Commercial Space Depth (min)	30 ft

e. Development Benefits

- i. Development is subject to the provisions of Article 12: Development Benefits of this Ordinance. Where the provisions of this section conflict with those of Article 12, the provisions of Article 12 apply.
- ii. Development of a Commercial Building must provide linkage payments in accordance with Section 12.2 Linkage.

6.5.8 Building Components

- a. Building components are accessory elements attached to the main mass of a building.
- b. Building components are permitted by Site Plan Approval as specified on Table 6.1.8.
 - i. At least one (1) storefront is required for each ground story commercial space.
- c. Building components not identified on Table 6.5.8 are prohibited.
- d. Unless otherwise specified, building components may attach to other building components to create assemblies of components.

Table 6.5.8 Building Components

	Commercial Building
Awning	P
Entry Canopy	P
Lobby Entrance	P
Storefront	P
Bay Window	P
Arcade	P

P - Permitted • SP - Special Permit Required • N - Not Permitted

e. Awning

- i. An awning is a wall mounted frame covered with fabric or other material that provides shade and weather protection over a storefront or building entrance.

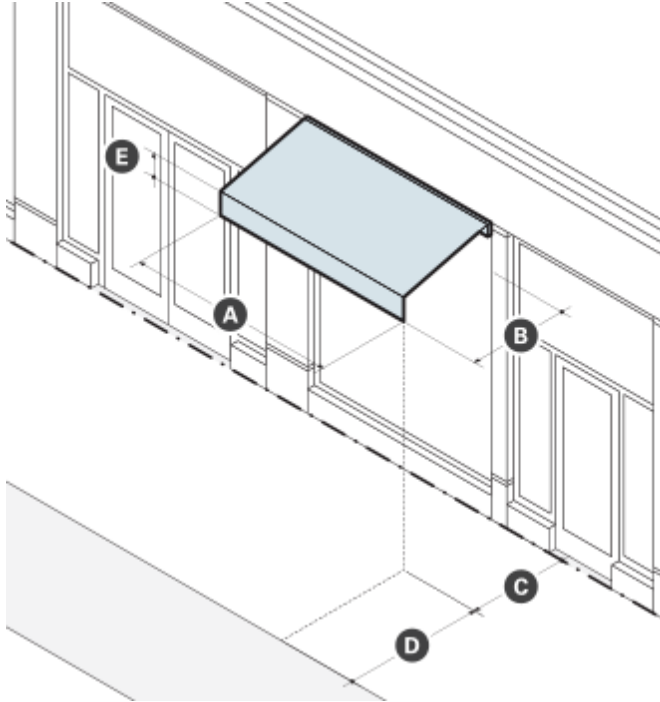

Dimensions	
A Width (min)	See ii. Standards
B Projection (min)	3 ft
C Clearance (min)	8 ft
Front Setback Encroachment (max)	100%
D Setback from Curb (min)	2 ft
E Valance Height (max)	12 in

- ii. Standards
 - a). Awnings must be securely attached to and supported by the building and must fit the windows or doors the awning is attached to.
 - b). An awning must be made of durable, weather-resistant material that is water repellent.
 - c). Internally illuminated or back-lit awnings are prohibited.
 - d). An awning that projects over the sidewalk of a public thoroughfare requires compliance with all City Ordinances.

f. Entry Canopy

- i. An entry canopy is a wall-mounted structure that provides shade and weather protection over a storefront or building entrance.

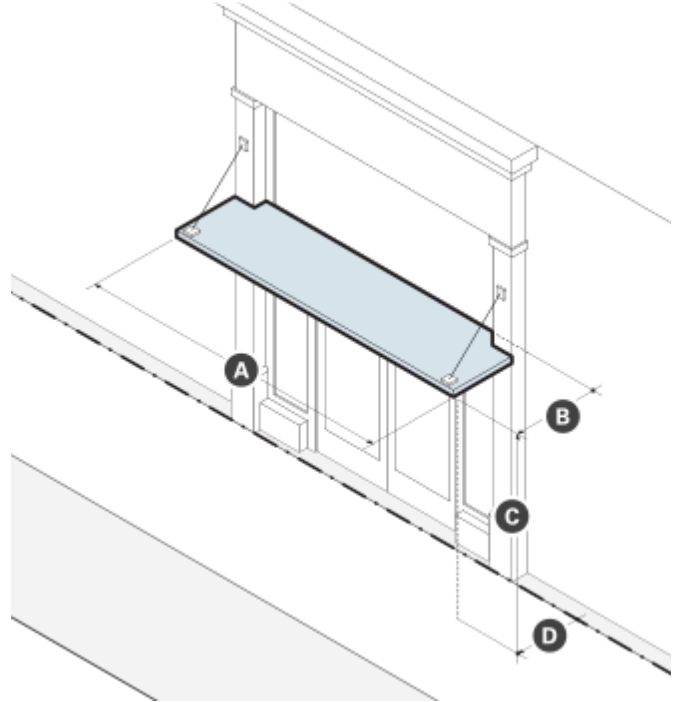

Dimensions	
A Width (min)	See ii. Standards
B Projection (min)	3 ft
C Clearance (min)	8 ft
D Front Setback Encroachment (max)	100%
Setback from Curb (min)	2 ft

- ii). Standards
 - a). Entry canopies must be visually supported by brackets, cables, or rods.
 - b). The width of an entry canopy must be equal to or greater than the width of the doorway surround or exterior casing it is mounted over.

g. Lobby Entrance

- i. A lobby entrance is a non-load bearing assembly of entry doors and windows providing access and light to the lobby of a building.

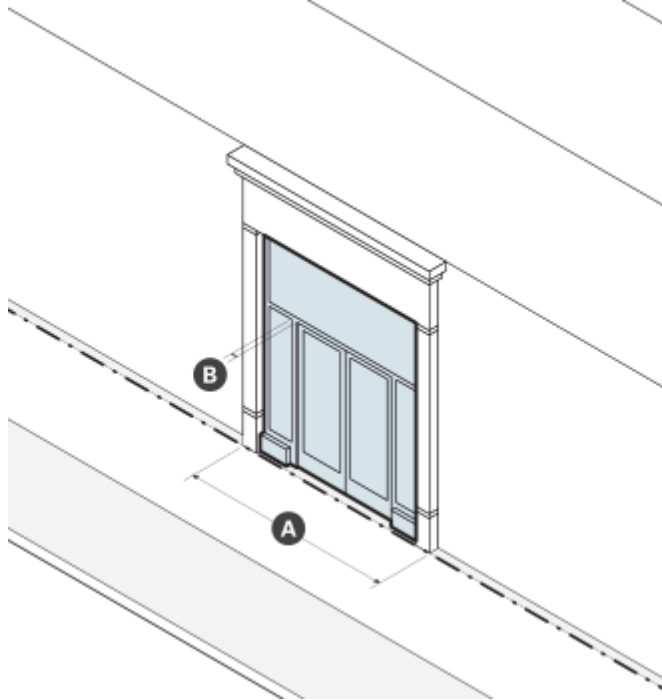

Dimensions	
A Width (min/max)	15 ft 30 ft
B Height (min)	80% of Ground Story Height
Recessed Entrance Width (max)	15 ft
Recessed Entrance Depth (max)	5 ft

- ii. Standards
 - a). When a lobby entrance is set back from the front lot line, the frontage area must be paved.

h. Storefront

- i. A storefront is a non-load bearing assembly of commercial doors and windows providing access and light to a commercial space and a place to display goods, services, and signs.

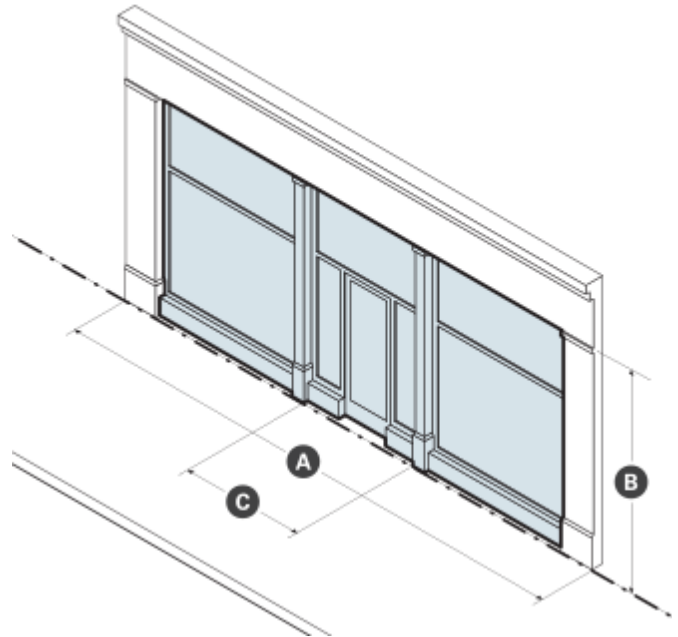

Dimensions	
A Width (min/max)	15 ft 30 ft
B Height (min)	80% of Ground Story Height
Display Window Height (min)	8 ft
Recessed Entrance Width (max)	15 ft
Recessed Entrance Depth (max)	5 ft

- ii. Standards
 - a). An unobstructed view of the interior space or a lighted and maintained merchandise display(s) must be provided for a depth of

at least four (4) feet behind storefront display windows.

- b). When storefronts are set back from the front lot line, the frontage area must be paved.
- c). When present, awnings and canopies must be mounted between columns, pilasters, or piers; above doorways and display windows; and below the sign band.
- d). Exterior security grilles, gates, and roll-down security doors and windows are prohibited.

i. Bay Window

i. A bay window is an assembly of windows projecting from a building to provide additional habitable space, increased light, multi-directional views, and articulation to an exterior wall.

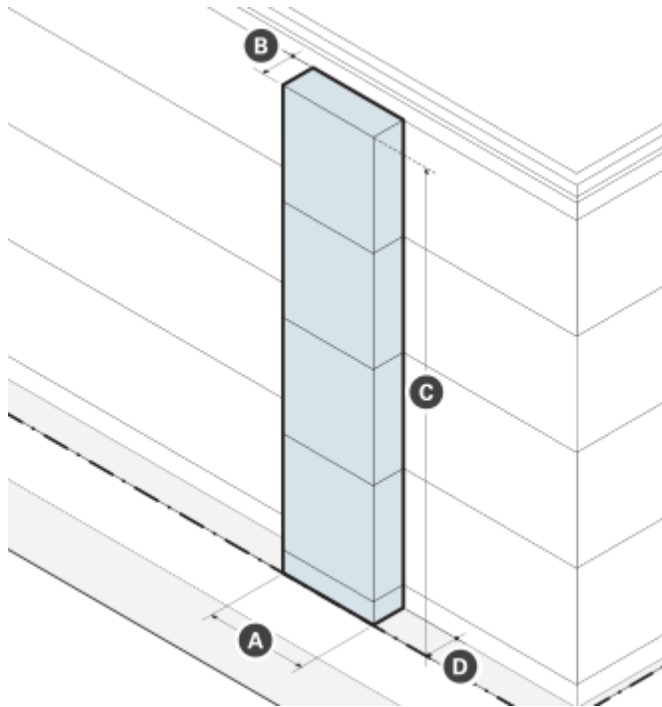

Dimensions	
A Width (min)	16 ft
B Projection (max)	3 ft
C Height (min)	Height of Building in Stories
D Setback Encroachment (max)	–
Front	3 ft
Side	0 ft
Rear	0 ft

j. Arcade

i. An arcade is a pedestrian walkway covered by the upper floors of a building. The ground story facade is setback and upper floors are supported by a colonnade or supports.

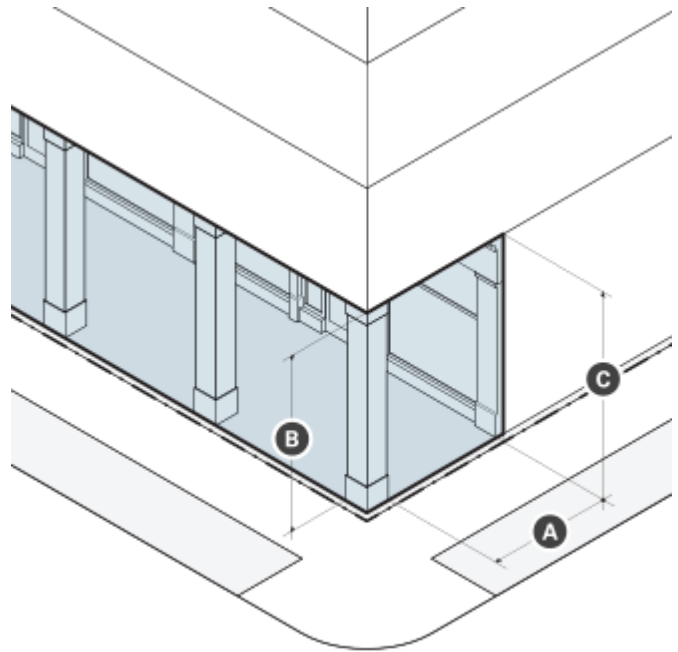

Dimensions	
A Depth (min/max)	10 ft 15 ft
B Height (max)	1 story

ii. Standards

- a). Arcades must extend the entire width of a building and must have a consistent depth.
- b). Support columns or piers may be spaced no farther apart than they are tall.
- c). Arcades are considered part of the building for the purpose of measuring facade build

ii. Standards

- a). Bay windows, including box and bow windows, must include at least three (3) windows for each story of the bay window.
- b). The cumulative width of multiple bays may equal up to fifty percent (50%) of the width of the exterior wall from which the bays project.
- c). Bays projecting over the sidewalk of a public thoroughfare must have at least two (2) stories of clearance and be compliant with all City Ordinances.
- d). Bay windows may have integrated recessed balconies, terraces, or roof decks.

out.

- d). Arcades may be combined only with storefront and lobby entrance frontages.
 - e). The finished ceiling of an arcade interior may be arched or flat, but must have a greater clearance than the openings between columns or piers.
-

6.5.9 Facade Design

- a. Facades must provide solid material framing each storefront and lobby entrance as follows:
 - i. pilasters or columns supporting a horizontal lintel and cornice;
 - ii. a spandrel positioned between pilasters or columns that extend from upper stories of the building to the ground; or
 - iii. flat wall above and to either side of a void or punched opening.
- b. Storefronts and lobby entrances must be set within the resulting frame provided for each by the facade.
- c. Materials framing each storefront or lobby entrance may be integrated into the design of the facade or customized for individual storefronts and lobby entrances.
- d. Mechanical louvers necessary for venting purposes are not permitted in the required frame, but may be incorporated into any storefront or lobby entrance system.

6.5.10 Architectural Design Guidelines

- a. Facades should be visually divided into a series of architectural bays that are derived, in general, from the building's structural bay spacing.
- b. Piers, pilasters, or other features defining each architectural bay should either extend all the way to the ground or terminate at any horizontal articulation defining the base of the building.
- c. Architectural bays should align, in general, with individual or groups of storefronts and lobby entrances.
- d. Piers, pilasters, or other features defining each architectural bay should always project forward and be uninterrupted by any horizontal articulation.
- e. Vents, exhausts, and other utility features on building facades should be architecturally integrated into the design of the building and should be located to minimize adverse effects on pedestrian comfort along sidewalks and within open spaces.
- f. Buildings at terminated vistas should be articulated with design features that function as focal points.
- g. Fenestration glazing should be inset from the plane of exterior wall surfaces.
- h. Ribbon windows should be avoided.
- i. Monotonous and repetitive storefront or lobby systems, awnings, canopies, sign types, colors, or designs should be avoided.
- j. Storefronts and lobby entrances should include awnings or canopies to provide weather protection for pedestrians and reduce glare for storefront display areas. Awnings should be open-ended and operable.
- k. Lobby entrances for upper story uses should be optimally located, well defined, clearly visible, and separate from the entrance for other ground story uses.
- l. Lobbies should be limited in both width and total area to preserve floor space and frontage for other ground story uses. Buildings should use any combination of facade articulation, a double-height ceiling, a distinctive doorway, a change in wall material, a change in paving material within the frontage area, or some other architectural element(s) to make lobbies visual and materially distinctive.

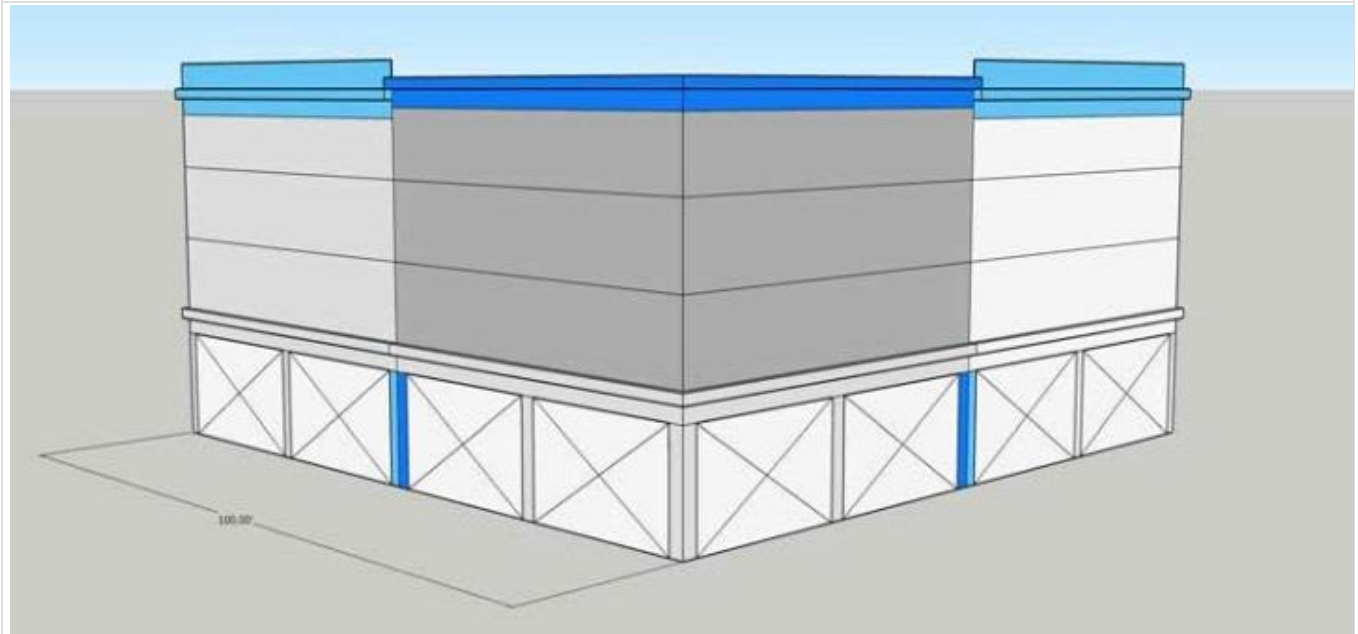
Figure 6.1.9 Storefront Framing

- m. The selection of materials, fenestration, and ornamentation should result in a consistent and harmonious composition that appears as a unified whole rather than a collection of unrelated parts.
- n. The type and color of materials should be kept to a minimum, preferably three (3) or fewer.
- o. Two (2) or more wall materials should be combined only one above the other, except for bay windows.
- p. Wall materials appearing heavier in weight should be used below wall materials appearing lighter in weight (wood and metal above brick, and all three above stone).
- q. Horizontal or vertical board siding or shingles, regardless of material, should be avoided.
- r. Architectural details and finish materials for the base of a building should be constructed of architectural concrete or pre-cast cementitious panels, natural or cast stone, heavy gauge metal panels, glazed or unglazed architectural terracotta, or brick.
- s. Exterior Insulation and Finish Systems (EIFS) should be avoided.

6.5.11 Use Provisions

- a. General
 - i. The use of real property is subject to the provisions of Article 9: Use Provisions of this Ordinance. Where the provisions of this section conflict with those of Article 9, the provisions of Article 9 apply.
 - ii. Unless otherwise specified, use categories are permitted as specified in the first column on Table 6.5.11.
 - iii. Use categories not identified on Table 6.5.11 are prohibited.
 - iv. All uses must comply with any use-specific standards applicable for each use in Section 9.2 Use Definitions & Standards.
 - v. Uses permitted by Special Permit require additional development review in accordance with §15.2.1 Special Permits.
- b. Additional Permitted Uses
 - i. For any building with two (2) or more stories, occupancy of a ground story commercial space fronting a pedestrian street is permitted as specified in the second column on Table 6.5.11.
 - a. Unless otherwise specified, only services associated with personal grooming such as barbers, hair salons, nail salons, or their subsequent equivalents are permitted from the Personal Services category.
- c. Required uses
 - i. At least ten percent (10%) of the gross leasable commercial floor space in any building must be provided as leasable floor area for principal uses from the Arts & Creative Enterprise use categories.

Table 6.5.11 Permitted Uses

Use Category Specific Use	1	2
Arts & Creative Enterprise Categories		
Artisanal Production	P	P
Artist Studios & Creative Incubators	P	P
Arts Education	P	P
Arts Exhibition	P	P
Arts Sales or Services	P	P
Design Services	P	P
Civic & Institutional Categories		
Community Center	P	P
Library	P	P
Minor Utility Facility	SP	N
Museum	P	P
Public Service	P	P
Religious & Educational Uses Protected by M.G.L. 40A. Sec. 3	P	P
Commercial Services Categories		
Assembly or Entertainment	SP	SP
Day Care Service (as noted below)	--	--
Child Day Care	P	P
Maintenance or Repair Services	P	P
Personal Services (except as follows)	P	P
Fitness Services	SP	SP
Funeral Services	N	N
Health Care Services	N	N
Recreation Services (except as follows)	SP	SP
Recreational Camp for Children	P	P
Vehicle Parking (as noted below)	--	--
Bike Share Parking	P	N
Car Share Parking (3 or less)	P	N
Car Share Parking (4 or more)	P	N
Commercial Parking Facility	P	N
Food and Beverage Service Categories		
Bar, Restaurant, Food Hall	SP	SP
Café or Coffee Shop	SP	SP
Industrial Categories		
Manufacturing	P	N
Office Categories		
Business Incubator	P	P

Table 6.5.11 Permitted Uses

Use Category Specific Use	1	2
Co-Working	P	P
General Office	N	N
Scientific Research and Development (except as follows)	P	N
Biomedical Technology	N	N
Medical or Diagnostic Laboratory	N	N
Testing Laboratory	P	N
Retail Sales Categories		
Fresh Food Market or Grocery Store	SP	SP
Farm/Vendor Market	SP	SP
Urban Agriculture Categories		
Farming (as noted below)	--	--
Commercial Farming	P	N
Community Farming	P	N
Community Gardening	P	N
Accessory Uses Categories		
Urban Agriculture (as noted below)	--	--
Commercial Farming	P	N
Vehicle Parking, Accessory	P	N
P - Permitted • SP - Special Permit Required • N - Not Permitted • (P or SP) - Permitted as specified per §6.1.11.b		

6.5.12 Development Standards

- a. General
 - i. Development is subject to the provisions of Article 10: Development Standards of this Ordinance. Where the provisions of this section conflict with those of Article 10, the provisions of Article 10 apply.
- b. Land Platting
 - i. Lots abutting rail rights-of-way may have frontage on an alley.
- c. Signs
 - i. A sign, individual numerals or letters, or a nonelectrical nameplate identifying the property address is required for all real property as follows:
 - a). Each ground story non-residential use must identify the street address either on the principal entrance door or above or beside the principal entrance of the use.
 - b). All residential building types must identify the street address either on the principal entrance door, above or beside the principal entrance, or on a mailbox.
 - ii. Address signs must be made easily visible through the use of colors or materials that contrast with the background material they are attached to and must be conspicuously located to provide visibility from the thoroughfare that the building faces.
 - iii. Address signs must be twelve (12) inches in height or less and may include the name of the occupant.

6.5.13 Parking & Mobility

- a. General
 - i. Vehicular parking must be provided as specified on Table 6.5.13.
 - ii. There are no parking requirements for accessory uses.
- b. Type
 - i. Motor vehicle parking may be provided as above ground structured parking or underground structured parking. Surface parking spaces are prohibited.
- c. Driveways
 - i. New driveways require a permit from the City Engineer.
 - ii. Driveways must be compliant with all City Ordinances and constructed in accordance with all standards established by relevant City Departments.
 - iii. Driveways are not permitted in the frontage area between a building and the front lot line.
 - iv. Driveways may be no wider than twenty four (24) feet in the frontage area of a lot.
 - v. Driveways may provide access in whole or in part on or across an abutting lot(s), provided that an access easement exists between all property owners.
- d. Parking Design
 - i. The design of all parking is subject to Section [11.1](#) Bicycle Parking and Section [11.2](#) Motor Vehicle Parking of this Ordinance.
- e. Unbundled Parking
 - i. Motor vehicle parking spaces must be rented or leased as an option rather than a requirement of the rental, lease, or purchase of a dwelling unit or non-residential floor space.
 - ii. Bicycle parking must be provided at no cost or fee to customers, visitors, employees, tenants, and residents.
- f. Parking Relief
 - i. Relief from the parking standards of Table 6.5.13 requires a Special Permit.
 - a). In addition to the review criteria for all Special Permits specified in [§15.2.1.e](#). Review Criteria, the review board shall make findings considering the following in its discretion to approve or deny a Special Permit authorizing relief from the parking standards of Table 6.1.13:
 - i). The supply and demand of on-street parking in the neighborhood, as determined through a parking study.
 - ii). Mobility management programs and services provided by the applicant to reduce the demand for parking.
 - iii). That parking provided in excess of any maximum permitted does not result in the increase in impervious lot area.

Table 6.5.13 Vehicular Parking

Use Category Specific Use	BICYCLE		MOTOR VEHICLE
	Short-Term (min)	Long-Term (min)	Within a Transit Area ¹ (max)
Arts & Creative Enterprise			
All Permitted Use Categories	0.10/1,000 sf	0.33/1,000 sf	1.20/1,000 sf
Civic & Institutional			
All Permitted Use Categories (except as follows)	0.50/1,000 sf	0.10/1,000 sf	5.00/1,000 sf
Minor Utility Facility	n/a	n/a	n/a
Commercial Services			
All Permitted Use Categories	0.40/1,000 sf	0.10/1,000 sf	1.20/1,000 sf
Food and Beverage Service			
All Permitted Use Categories	1.00 / 1,000 sf	0.20/1,000 sf	3.33/1,000 sf
Industrial			
All Permitted Use Categories	0.10/1,000 sf	0.33/1,000 sf	1.10/1,000 sf
Office			
All Permitted Use Categories	0.05/1,000 sf	0.33/1,000 sf	1.10/1,000 sf
Retail Sales			
All Permitted Use Categories (except as follows)	1.00 / 1,000 sf	0.10/1,000 sf	2.00/1,000 sf
Farm/Vendor Market	n/a	n/a	n/a

sf - Gross Leasable Square Footage • U - Dwelling Unit • RU - Rooming Unit
¹ See the Transit Area Map

6.5.14 Public Realm

- a. Sidewalks
 - i. For any lot abutting a sidewalk that is less than twelve (12) feet in width, the frontage area must be paved to provide a sidewalk that is at least twelve (12) feet in total width.
- b. Sidewalk Curb Cuts
 - i. A curb cut requires a permit from the City Engineer and must be compliant with all City Ordinances.
 - ii. Unless otherwise specified, the City Engineer may not permit more than one (1) curb cut per front lot line of a lot.
 - iii. Curb cuts are prohibited along all thoroughfares designated as a pedestrian street.
 - iv. Curb cuts must be located to minimize conflicts with pedestrians and bicyclists and must have a clear distance from fire hydrants, street trees, utility poles, and other furnishings as deemed necessary by the City Engineer.
 - a). Curb cuts for commercial or high-volume driveways should be at least one-hundred (100) feet from an unsignalized or signalized intersection.
 - b). Curb cuts for residential driveways should be at least twenty (20) feet from an unsignalized intersection and at least forty (40) feet from a signalized intersection.
 - v. The interior width of a curb cut (between curb stones) may be no wider than the driveway, vehicular entrance, or loading facility it serves.
 - vi. A driveway apron may be installed only within the furnishing zone of a sidewalk and must be constructed in accordance with all standards established by relevant City Departments.
 - vii. The grade, cross slope, and clear width of the walkway of a sidewalk must be maintained between the driveway apron and the abutting driveway. The appearance of the walkway (ie. scoring pattern or paving material) must indicate that, although a vehicle may cross, the area traversed by a vehicle remains part of the sidewalk.

Figure 6.5.14 Sidewalk Curb Cuts

Table 9.1.1

Table 9.1.1 Permitted Uses													
Use Category Specific Use	NR	UR	MR3	MR4	MR5	MR6	HR	FAB	R&D	CC	CI	CB	CIV
Arts & Creative Enterprise Categories													
Artisanal Production	N	N	P	P	P	P	P	P	<u>P</u>	P	P	P	N
Artist Studios & Creative Incubators	N	N	P	P	P	P	P	P	<u>P</u>	P	P	P	N
Arts Education	N	N	P	P	P	P	P	P	<u>P</u>	P	P	P	N
Arts Exhibition	N	N	P	P	P	P	P	P	<u>P</u>	P	P	P	N
Arts Sales or Services	N	N	P	P	P	P	P	P	<u>P</u>	P	P	P	N
Design Services	N	N	P	P	P	P	P	P	<u>P</u>	P	P	P	N
Auto-Oriented Categories													
Commercial Vehicle Repair or Maintenance	N	N	N	N	N	N	N	N	<u>N</u>	N	SP	SP	N
Dispatch Service (except as follows)	N	N	N	N	N	N	N	N	<u>N</u>	N	P	P	N
Towing Service	N	N	N	N	N	N	N	N	<u>N</u>	N	SP	SP	N
Gasoline Station	N	N	N	N	N	N	N	N	<u>N</u>	N	N	N	N
Personal Vehicle Repair or Maintenance	N	N	N	N	N	N	N	N	<u>N</u>	N	SP	SP	N
Recharging Station	N	N	P	P	P	P	P	N	<u>N</u>	P	P	P	N
Vehicle Sales	N	N	N	N	N	N	N	N	<u>N</u>	N	SP	SP	N
Cannabis Establishment Categories													
Cannabis Cultivation	N	N	SP	SP	SP	SP	SP	SP	<u>N</u>	SP	SP	SP	N
Cannabis Product Manufacturing	N	N	N	N	N	N	N	P	<u>N</u>	N	P	N	N
Cannabis Retail Sales	N	N	SP	SP	SP	SP	SP	N	<u>N</u>	SP	SP	SP	N
Cannabis Research & Development	N	N	P	P	P	P	P	N	<u>N</u>	P	P	P	N
Cannabis Testing Laboratory	N	N	P	P	P	P	P	N	<u>N</u>	P	P	P	N
Civic & Institutional Categories													
Community Center	N	N	P	P	P	P	P	P	<u>P</u>	P	N	N	N
Hospital	N	N	SP	SP	SP	SP	SP	N	<u>N</u>	SP	SP	N	N
Library	N	N	P	P	P	P	P	P	<u>P</u>	P	N	N	N
Minor Utility Facility	SP	SP	SP	SP	SP	SP	SP	SP	<u>SP</u>	SP	SP	SP	SP
Major Utility Facility	N	N	N	N	N	N	N	N	<u>N</u>	N	N	N	N
Museum	N	N	P	P	P	P	P	P	<u>P</u>	P	N	N	N
Private Non-Profit Club or Lodge	N	N	SP	SP	SP	SP	SP	N	<u>N</u>	SP	N	N	N
Public Service	P	P	P	P	P	P	P	P	<u>P</u>	P	P	P	P
Religious & Educational Uses Protected by M.G.L. 40A. Sec. 3	P	P	P	P	P	P	P	P	<u>P</u>	P	P	P	P
Commercial Services Categories													
Animal Services (as noted below)	-	-	-	-	-	-	-	-	<u>--</u>	-	-	-	-
Commercial Kennel	N	N	SP	SP	SP	SP	SP	N	<u>N</u>	SP	P	P	N
Pet Grooming	N	N	P	P	P	P	P	N	<u>N</u>	P	P	P	N
Pet Day Care or Training	N	N	SP	SP	SP	SP	SP	N	<u>N</u>	SP	P	P	N

Table 9.1.1 Permitted Uses

Use Category Specific Use	NR	UR	MR3	MR4	MR5	MR6	HR	FAB	R&D	CC	CI	CB	CIV
Veterinarian	N	N	SP	SP	SP	SP	SP	N	<u>N</u>	SP	P	P	N
Assembly or Entertainment	N	N	SP	SP	SP	SP	SP	N	<u>SP</u>	SP	SP	SP	N
Banking or Financial Services (except as follows)	N	N	P	P	P	P	P	N	<u>N</u>	P	P	P	N
Personal Credit	N	N	SP	SP	SP	SP	SP	N	<u>N</u>	SP	SP	SP	N
Building or Home Repair Services	N	N	SP	SP	SP	SP	SP	N	<u>N</u>	SP	P	P	N
Business Support Services	N	N	P	P	P	P	P	N	<u>N</u>	P	P	P	N
Caterer or Wholesale Food Production	N	N	SP	SP	SP	SP	SP	P	<u>N</u>	SP	P	P	N
Day Care Services (as noted below)	–	–	–	–	–	–	–	–	<u>–</u>	–	–	–	–
Adult Day Care	N	N	P	P	P	P	P	N	<u>P</u>	P	P	P	N
Child Day Care	P	P	P	P	P	P	P	P	<u>P</u>	P	P	P	N
Educational Services	N	N	P	P	P	P	P	P	<u>N</u>	P	P	P	N
Maintenance or Repair Services	N	N	P	P	P	P	P	N	<u>P</u>	P	P	P	N
Personal Services (except as follows)	N	N	P	P	P	P	P	N	<u>P</u>	P	P	P	N
Fitness Services	N	N	P	P	P	P	P	P	<u>SP</u>	P	P	P	N
Funeral Services	N	N	SP	SP	SP	SP	SP	N	<u>N</u>	SP	P	P	N
Health Care Services	N	N	SP	SP	SP	SP	SP	N	<u>N</u>	SP	SP	SP	N
Recreation Services (except as follows)	N	N	SP	SP	SP	SP	SP	SP	<u>SP</u>	SP	P	P	P
Recreational Camp for Children	P	P	P	P	P	P	P	P	<u>P</u>	P	P	P	P
Vehicle Parking (as noted below)	–	–	–	–	–	–	–	–	<u>–</u>	–	–	–	–
Bike Share Parking	N	P	P	P	P	P	P	P	<u>P</u>	P	P	P	P
Car Share Parking (3 or less)	N	P	P	P	P	P	P	P	<u>P</u>	P	P	P	N
Car Share Parking (4 or more)	N	SP	P	P	P	P	P	P	<u>P</u>	P	P	P	N
Commercial Parking	N	N	P	P	P	P	P	P	<u>P</u>	P	P	P	N
Food and Beverage Services Categories													
Bar, Restaurant, or Food Hall	N	N	P	P	P	P	P	N	<u>SP</u>	P	P	P	N
Café or Coffee Shop	N	N	P	P	P	P	P	N	<u>SP</u>	P	P	P	N
Industrial Categories													
Dry Cleaning or Laundry Services	N	N	N	N	N	N	N	N	<u>N</u>	N	SP	N	N
Data Center	N	N	N	N	N	N	N	N	<u>N</u>	N	SP	N	N
Manufacturing	N	N	N	N	N	N	N	P	<u>P</u>	N	P	N	N
Moving or Storage Services (except as follows)	N	N	N	N	N	N	N	N	<u>N</u>	N	P	N	N
Self-Storage	N	N	N	N	N	N	N	N	<u>N</u>	N	SP	SP	N
Recycling Collection	N	N	N	N	N	N	N	N	<u>N</u>	N	SP	N	N
Salvage Yard	N	N	N	N	N	N	N	N	<u>N</u>	N	N	N	N
Trucking or Transportation Depot	N	N	N	N	N	N	N	N	<u>N</u>	N	SP	N	N
Wholesale Trade or Distribution	N	N	N	N	N	N	N	P	<u>N</u>	N	P	N	N
Lodging Categories													

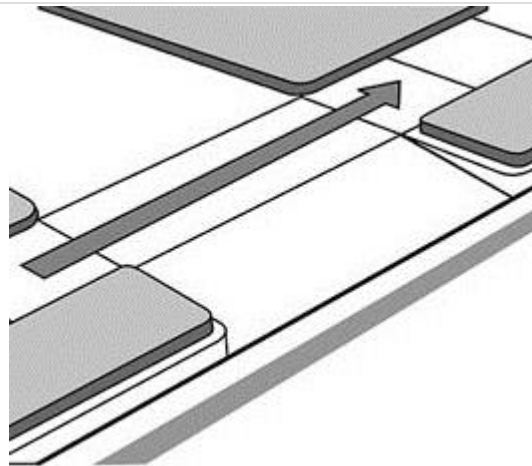
Table 9.1.1 Permitted Uses

Use Category Specific Use	NR	UR	MR3	MR4	MR5	MR6	HR	FAB	R&D	CC	CI	CB	CIV
Bed & Breakfast	SP	SP	SP	SP	SP	SP	SP	N	<u>N</u>	SP	N	N	N
Hotel or Hostel	N	N	SP	SP	SP	SP	SP	N	<u>N</u>	SP	SP	SP	N
Office Categories													
Business Incubator	N	N	P	P	P	P	P	N	<u>P</u>	P	P	P	N
Co-Working	N	N	P	P	P	P	P	N	<u>P</u>	P	P	P	N
General Office	N	N	P	P	P	P	P	N	<u>N</u>	P	P	P	N
Scientific Research and Development (except as follows)	N	N	P	P	P	P	P	N	<u>P</u>	P	P	P	N
Biomedical Technology	N	N	N	N	N	P	P	N	<u>N</u>	P	P	P	N
Medical Laboratory	N	N	P	P	P	P	P	N	<u>N</u>	P	P	P	N
Testing Laboratory	N	N	P	P	P	P	P	N	<u>P</u>	P	P	P	N
Residential Categories													
Residential Housing	P	P	SP	SP	SP	SP	SP	N	<u>N</u>	N	N	N	N
Artist Housing	P	P	SP	SP	SP	SP	SP	N	<u>N</u>	N	N	N	N
Institutional Housing (except as follows)	N	SP	SP	SP	SP	SP	SP	N	<u>N</u>	N	N	N	N
Community or Group Residence	P	P	P	P	P	P	P	N	<u>N</u>	N	N	N	N
Retail Sales Categories													
Building/Home Supplies or Equipment	N	N	SP	SP	SP	SP	SP	N	<u>N</u>	SP	P	P	N
Consumer Goods (except as follows)	P	P	P	P	P	P	P	N	<u>N</u>	P	P	P	N
Alcohol Sales	N	N	SP	SP	SP	SP	SP	N	<u>N</u>	SP	SP	SP	N
Firearms Sales	N	N	N	N	N	N	N	N	<u>N</u>	N	N	N	N
Pet Store	N	N	SP	SP	SP	SP	SP	N	<u>N</u>	SP	SP	SP	N
Fresh Food Market or Grocery Store	P	P	P	P	P	P	P	N	<u>SP</u>	P	SP	P	N
Farm/Vendor Market	N	N	P	P	P	P	P	N	<u>SP</u>	P	P	P	N
Urban Agriculture Categories													
Farming (as noted below)	-	-	-	-	-	-	-	-	<u>-</u>	-	-	-	-
Commercial Farming	N	N	P	P	P	P	P	P	<u>P</u>	P	P	P	N
Community Farming	P	P	P	P	P	P	P	P	<u>P</u>	P	P	P	P
Community Gardening	P	P	P	P	P	P	P	P	<u>P</u>	P	P	P	P
Accessory Use Categories													
Home Occupations (as noted below)	-	-	-	-	-	-	-	-	<u>-</u>	-	-	-	-
Hobby Kennel	SP	N	N	N	N	N	N	N	<u>N</u>	N	N	N	N
Home-Based Business	P	P	N	N	N	N	N	N	<u>N</u>	N	N	N	N
Home-Based Day Care	SP	N	N	N	N	N	N	N	<u>N</u>	N	N	N	N
Home Office	P	P	P	P	P	P	P	N	<u>N</u>	N	N	N	N
Urban Agriculture (as noted below)	-	-	-	-	-	-	-	-	<u>-</u>	-	-	-	-

Table 9.1.1 Permitted Uses

Use Category Specific Use	NR	UR	MR3	MR4	MR5	MR6	HR	FAB	R&D	CC	CI	CB	CIV
Apiculture	P	P	P	P	P	P	P	N	<u>P</u>	N	N	N	N
Aviculture	P	P	P	P	P	P	P	N	<u>N</u>	N	N	N	N
Commercial Farming	P	P	P	P	P	P	P	P	<u>P</u>	P	P	P	N
Residential Gardening	P	P	P	P	P	P	P	N	<u>N</u>	N	N	N	N
Vehicle Parking, Accessory (except as follows)	P	P	P	P	P	N	N	P	<u>P</u>	N	P	P	N
Home Business Vehicle Parking	SP	SP	N	N	N	N	N	P	<u>N</u>	N	N	N	N

P - Permitted • SP - Special Permit Required • N - Not Permitted

9.2.2 Arts & Creative Enterprise Use Categories

a. Artisanal Production

The on-site production of hand-fabricated or hand-manufactured parts and custom or craft consumer goods based on the skill and knowledge of the artisan and the use of hand tools or small-scale, light mechanical equipment. The artisanal production category includes apparel manufacturing, breweries, cabinetry, chocolatiers, confectionery, furniture making, glass working, jewelry making, metal working, pottery, sculpture, wood working, and their substantial equivalents. Showrooms and the ancillary sales of goods produced on-site are permitted. The following standards apply:

- i. The production of offensive noise, vibration, smoke, dust or other particulate matter, heat, humidity, glare, or other objectionable effect is prohibited, except in the Fabrication~~and~~, Commercial Industry~~,~~ and Research & Development districts.

10.1.4 Lots

- c. ~~All~~ Unless otherwise specified, all lots must have frontage on a civic space or a thoroughfare, excluding alleys.
 - i. Lots abutting only a civic space at the front lot line must also abut an alley at the rear or side.
- d. Unless otherwise specified, lots must have ~~a~~ dimensions appropriate for one or more of the building type(s) or civic space types permitted for the district where the lot is located.
 - i. Corner, interior, and key lots are permitted.
 - ii. Flag lots are prohibited.
 - iii. Through lots are prohibited in the Neighborhood Residence and Urban Residence districts.
- e. To avoid creating irregular lot shapes, lots must be platted to be generally rectilinear, where the side lot lines are within 45 degrees of perpendicular to the front lot line or to the tangent of a curved front lot line, and generally straight throughout their length.