

ALD DAVIS
2 UTILITY REPS.



CITY OF SOMERVILLE, MASSACHUSETTS
CITY CLERK'S OFFICE
JOSEPH A. CURTATONE
MAYOR

JOHN J. LONG
CITY CLERK

October 17, 2017

NOTICE

You are hereby notified that the Board of Aldermen will hold a Public Hearing on the following Petition. You are receiving this Notice because City records indicate that you own property that abuts the work that is being proposed. You and other members of the public are invited to attend and be heard at this Hearing.

PETITION: Patriot Custom Homes requests a Grant of Location to install 36 feet of conduit in Chandler Street, from Pole 227/9 to a point of pickup at 74 Chandler Street.

PLACE: Aldermanic Chambers, 2nd Floor, City Hall, 93 Highland Avenue, Somerville.

TIME: Thursday, October 26, 2017, at 7:00 PM.

PURPOSE: The work is necessary to provide telecommunications services to 74 Chandler Street.

John J. Long
City Clerk



CITY OF SOMERVILLE, MASSACHUSETTS

DEPARTMENT OF PUBLIC WORKS

JOSEPH A. CURTATONE

MAYOR

STAN KOTY
Commissioner

RICK WILLETTE
Director of Operations

October 13, 2017

The Honorable Board of Aldermen
City Hall
93 Highland Avenue
Somerville MA, 02143

**RE: Grant of Location
Patriot Custom Homes
74 Chandler Street**

Dear Board Members:

Preliminary approval is recommended for the petition and plan of Patriot Custom Homes to install approximately 36 feet of (2) 1.5 inch PVC conduit from pole 227/9 on Chandler Street to 74 Chandler Street. This conduit will be used to house communication cables. Chandler Street is a public way in Somerville, MA.

This recommendation is made with reference to Patriot Custom Homes plans of October 4, 2017 and October 12, 2017, upon stipulation that the Grant of Location is subject to: a reservation of rescission by the Board of Aldermen; indemnification of the City for all liability arising from said Grant; all permit procedures, conditions and approvals of municipal utilities; protection of existing infrastructure; and complete surface repair, restoration and maintenance. A public hearing will be required.

Respectfully requested,

Department of Public Works

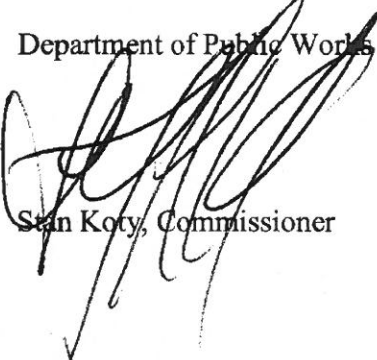
Stan Koty, Commissioner

1 Franey Road Somerville, Massachusetts 02145

(617) 625-6600 Ext 5100 TTY (866) 808-4851 Fax (617) 623-7649

www.somervillema.gov



CITY OF SOMERVILLE
Commonwealth of Massachusetts
93 Highland Avenue
Somerville, MA 02143
(617) 625-6600

BUSINESS LICENSE APPLICATION - Grant of Location

File #: 17-018534

License #: BL17-000139

Address: 74 CHANDLER ST

Licensee: Dylan James Patriot Custom Homes, LLC

DBA Name: Patriot Custom Homes

Business Ownership Type: LLC

Legal Name of Entity: Patriot Custom Homes, LLC.

Owners/Officers: Dylan F. James, , ,

License Information:

Grant of location issued to: Patriot Custom Homes, LLC

Describe the reason for the work, and the intended beneficiaries: Installing electrical conduit for low voltage communication wires to provide service to 74 Chandler Street.

Insert here the same detailed description of the work as appears in the attached Grant of Location Order: In Chandler Street, northwesterly from Pole 227/9, approximately 197 feet north of William Street, installing conduit a distance of about 36 feet from the Pole to a point of pickup at 74 Chandler Street, for communications use.

Approval Conditions:

**ORDER FOR GRANT OF LOCATION FOR
WIRES, CABLES, POLES, PIERS, ABUTMENTS, CONDUITS OR FIXTURES**

**City of Somerville, Massachusetts
In Board of Aldermen**

WHEREAS, Patriot Custom Homes, LLC (hereinafter known as the PETITIONER) has petitioned for permission to construct upon, along, under or across the public way(s) of the City of Somerville, the following (describe work):

In Chandler Street, northwesterly from Pole 227/9, approximately 197 feet north of William Street, installing conduit a distance of about 36 feet from the Pole to a point of pickup at 74 Chandler Street. This conduit is being installed for communication use.

AND WHEREAS, notice has been given and a hearing held on said petition as provided by law; NOW THEREFORE BE IT

ORDERED that the PETITIONER be and hereby is granted permission by the Board of Aldermen to complete the construction described above, all in accordance with the following conditions:

1. PETITIONER shall locate and complete all work as shown by plan(s) dated September 30, 2017, by Patriot Custom Homes, LLC, and as may have been amended by the City.
2. PETITIONER shall comply with the requirements of existing ordinances and such as may hereafter be adopted governing the construction.
3. PETITIONER shall perform all work to the requirements and satisfaction of the Department of Public Works or other such officer(s) as may be hereafter appointed by the City.

Approved by the Board of Aldermen on the _____ day of _____, 20____,

A True Record. Attest: _____ Date: _____
City Clerk

Certificate

I hereby certify that the foregoing Order was adopted by the Board of Aldermen on the _____ day of _____, 20____, after due notice and public hearing as prescribed by Section 22 of Chapter 166 of the General Laws and any additions or amendments thereto, said public hearing held in said City on the _____ day of _____, 20____, and recorded with the records of Grant of Location Orders of said City, in Book _____, Page _____.

Certified. Attest: _____ Date: _____
City Clerk

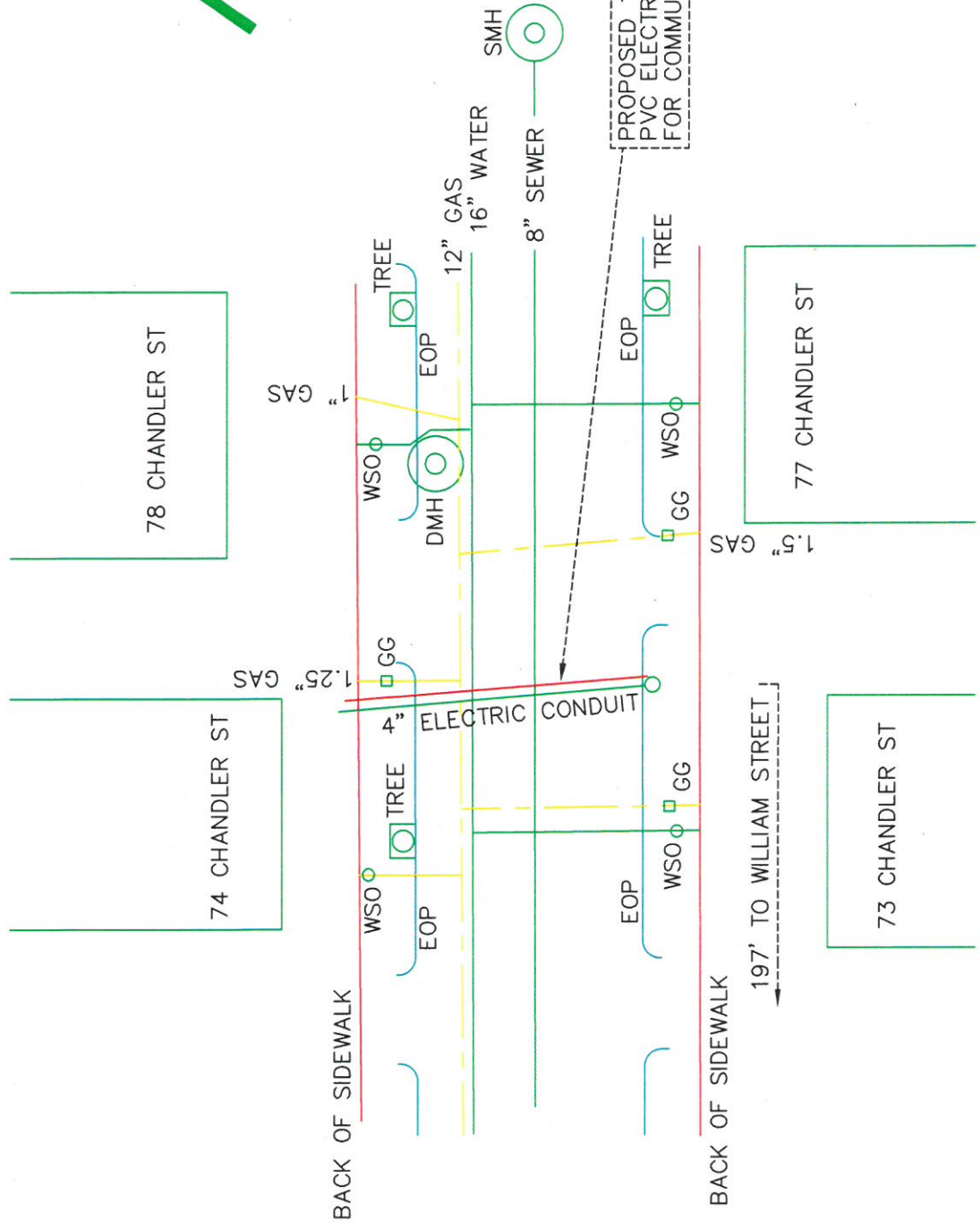
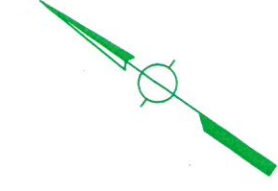

Patriot Custom Homes, LLC.
 9 Cypress Drive
 Burlington, Massachusetts 01803
 781-750-8889

PROPOSED ELECTRIC CONDUIT LOCATION
 74 CHANDLER STREET
 SOMERVILLE MASSACHUSETTS

SCALE N.T.S.
 SEPTEMBER 30, 2017

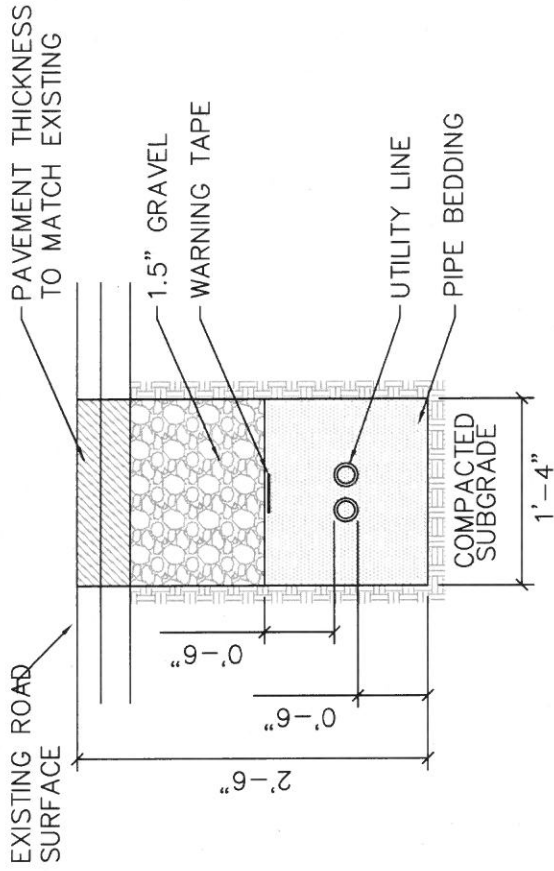

NOTES:

1. PROVIDE 6" SAND BEDDING AROUND ALL PIPES.
2. GRAVEL TO BE COMPACTED IN 6" LIFTS.
3. ROADWAY AND SIDEWALK PAVING TO MATCH EXISTING.

TYP. UTILITY TRENCH

SCALE: NTS

Patriot Custom Homes, LLC.
 9 Cypress Drive
 Burlington, Massachusetts 01803
 781-750-8889

PROPOSED ELECTRIC CONDUIT DETAIL
 74 CHANDLER STREET
 SOMERVILLE MASSACHUSETTS

SCALE N.T.S.

OCTOBER 12, 2017

74 Chandler Street
Somerville, MA 02144
Ward: 6-3

Abutters List

16/D/4
73 Chandler Street
Nasser Richard M
C/O Wynn Kathleen M
13 Elm Street
Brookline, MA 02445

16/C/30
74 Chandler Street
Moreno Evelyn V Tr
Sound Realty Trust
C/O Nixon Peabody LLP
74 Chandler Street
Somerville, MA 02144

16/D/5
77 Chandler Street
O'Meara Kathleen Patricia Trustee
C/O Kathleen P. O'Meara 2008 Family Trust
77 Chandler Street
Somerville, MA 02144

16/C/29
78 Chandler Street
Teebaggy Mary Et Al Trustees
C/O The Teabaggy Family Trust
78 Chandler Street
Somerville, MA 02144

Roger Greene
185 Morrison Avenue, Apt 202
Somerville, MA 02144