



**CITY OF SOMERVILLE**  
Commonwealth of Massachusetts  
93 Highland Avenue  
Somerville, MA 02143  
(617) 625-6600

## BUSINESS LICENSE APPLICATION - Grant of Location

File #: 24-025995  
License #: BL24-000163  
Address: 1 FITCHBURG ST  
Licensee: Erica Hudson Siena Engineering Group  
DBA Name: Cambridge Network Solutions

Business Ownership Type: Corporation  
Legal Name of Entity: Cambridge Network Solutions  
Owners/Officers: , , ,

### License Information:

**Grant of location issued to:** CNS

**Describe the reason for the work, and the intended beneficiaries:** This work is to provide service to the surrounding area.

**Insert here the same detailed description of the work as appears in the attached Grant of Location**

**Order:** The proposed conduit installation will begin by breaking out of existing Eversource electrical MH#22014 on Linwood St to the proposed 3'x3' CNS Handhole which will include one (1) 4-inch PVC schedule 40 conduit. The conduit will continue to the proposed point of entry at 1 Fitchburg St which will include one (1) 4-inch PVC schedule 40 conduit. A total of approximately 114 feet.

### Approved By:

**Malik Drayton, Approved with Conditions**

APPROVAL CONDITION: MD20241119: Contractor shall take all necessary precautions to avoid damaging any tree or tree part with equipment.

APPROVAL CONDITION: MD20241119: All nearby street tree(s) shall be protected prior to and during all construction activities using TREE BOX or TREE WRAPS. . TREE BOX shall be constructed from 2 in. x 4 in. lumber creating a box around the border of the tree pit with 2 in. x 4 in. lumber standing straight up at the corners and wrapped with orange snow fence. Detail attached. . TREE WRAPS (TREE TRUNK WRAPPING PROTECTION LUMBER) shall consist of 2 in. x 4 in. and 8 ft. height lumber wired together in close spacing with zip ties or 16 gauge galvanized steel wire to form a protective enclosure around tree trunks. Use burlap to separate the wood from the bark if necessary to prevent wood from scraping or bruising bark. Do not use staples or puncture the trunk in any way.

APPROVAL CONDITION: MD20241119: Any tree roots less than two (2) inches in diameter that cannot be avoided during construction shall be carefully and cleanly cut with a clean pair of pruning shears or loppers. Roots are to be cut back flush with the edge of the trench. If any tree roots greater than two (2) inches in diameter are encountered, stop work immediately and contact the City Urban Forester. Any and all pruning of roots greater than 2 inches in diameter must be completed under the supervision of the City Urban Forester.

**Eric Weisman, Approved**

**Mads Filtenborg, Approved with Conditions**

APPROVAL CONDITION 11/14/24-MF: Concrete sidewalk to be restored in-kind after conduit installation.  
APPROVAL CONDITION 11/14/24-MF: Any work requiring the use of the street and/or sidewalk will require a Street/Sidewalk Occupancy Permit from the Engineering Department. Apply via Citizen Serve before conduit installation.

APPROVAL CONDITION 11/14/24-MF: 12 ft wide permanent patch centered on trench to be installed on the following calendar year after completion.

APPROVAL CONDITION 11/14/24-MF: Bricks cannot be cut; brick crosswalks must be reset immediately following installation.

**Kimberly M. Wells, Approved**



CITY OF SOMERVILLE, MASSACHUSETTS  
CITY CLERK'S OFFICE  
KATJANA BALLANTYNE  
MAYOR

KIMBERLY M. WELLS  
CITY CLERK

December 2, 2024

**NOTICE OF PUBLIC HEARING**

You are hereby notified that the Somerville City Council will hold a Public Hearing on the following Petition. You are receiving this Notice because the Petitioner has reported that you own property that abuts the work that is being proposed. You and other members of the public are invited to attend and be heard at this Hearing.

**This meeting of the City Council will also be conducted via remote participation, online in a webinar hosted on the Zoom platform.**

You have three ways to be heard at this meeting:

1. To attend and be heard, enter the link exactly as it appears below into your internet browser any time before the meeting. You will then be asked to register for the meeting. After registering, you will receive an email with instructions to join the webinar when it starts.
2. You may also testify in person in the City Council Chamber, City Hall, 2<sup>nd</sup> Floor, 93 Highland Avenue, Somerville, MA 02143
3. If you are unable to attend but wish to be heard, you may send written comments by US mail to the City Clerk at the address below, or by email to [cityclerk@somervillema.gov](mailto:cityclerk@somervillema.gov). Your comments must arrive no later than 12 Noon on the day of the Hearing, in order to be sure they are conveyed to the Council.

**PETITION:** Cambridge Network Solutions is applying for a Grant of Location to install approximately 114 feet of conduit in Linwood Street and Fitchburg Street, from MH22014 to a proposed CNS Handhole and continuing to a point of pickup at 1 Fitchburg Street.

**PLACE:** [https://us02web.zoom.us/webinar/register/WN\\_SoEmaMuPSVa-u1gcHjHvhQ](https://us02web.zoom.us/webinar/register/WN_SoEmaMuPSVa-u1gcHjHvhQ) or City Council Chambers, City Hall, 2<sup>nd</sup> Floor, 93 Highland Avenue, Somerville, MA 02143

**TIME:** Thursday, December 12, 2024, at 7:00 PM.

**PURPOSE:** The work is necessary to provide service to the surrounding area.



CAMBRIDGE NETWORK SOLUTIONS

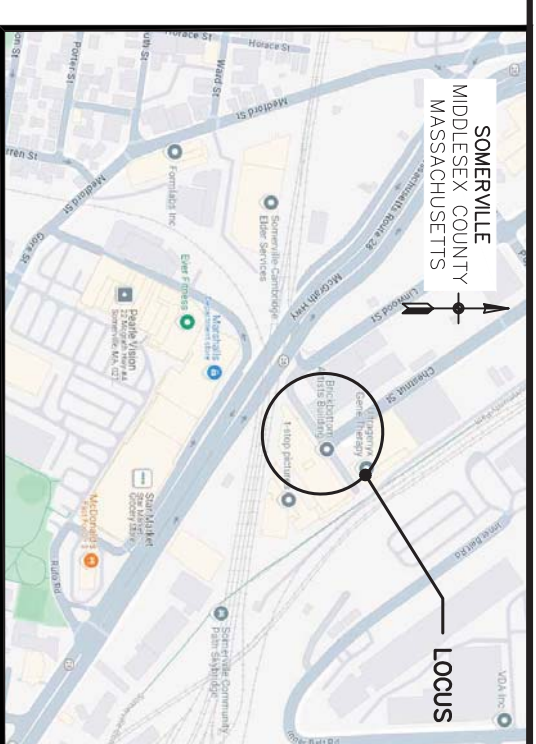

LOCUS MAP  
NOT TO SCALE

# PROPOSED CONDUIT PLACEMENT PLAN 1 FITCHBURG STREET SOMERVILLE, MASSACHUSETTS

## SHEET INDEX

- TITLE SHEET
- 1. PROPOSED CONDUIT PLACEMENT PLAN
- 2. DETAIL SHEET
- 3. DETAIL SHEET
- 4. DETAIL SHEET
- 5. LEGEND & NOTES

REGISTRY BOX



Brian C.  
Dorwart

CITY OF SOMERVILLE

PUBLIC WORKS DEPARTMENT

ENGINEERING DIVISION  
GRANT OF LOCATION PLAN

PROPOSED LATERAL CONDUIT PLACEMENT  
1 FITCHBURG STREET

C:\Users\ystoker\AppData\Local\Temp\AcPublish\_20080\24-20014\_1 Fitchburg Street.dwg  
Oct. 17, 2024 - 3:53pm by rstoker

PREPARED BY:



PREPARED FOR:



SHEET NUMBER:

CV

Designed by **R. STOKER**

Checked by **J. KENNEDY**

Date  
**OCTOBER 17, 2024**

TITLE SHEET

15 LINWOOD STREET

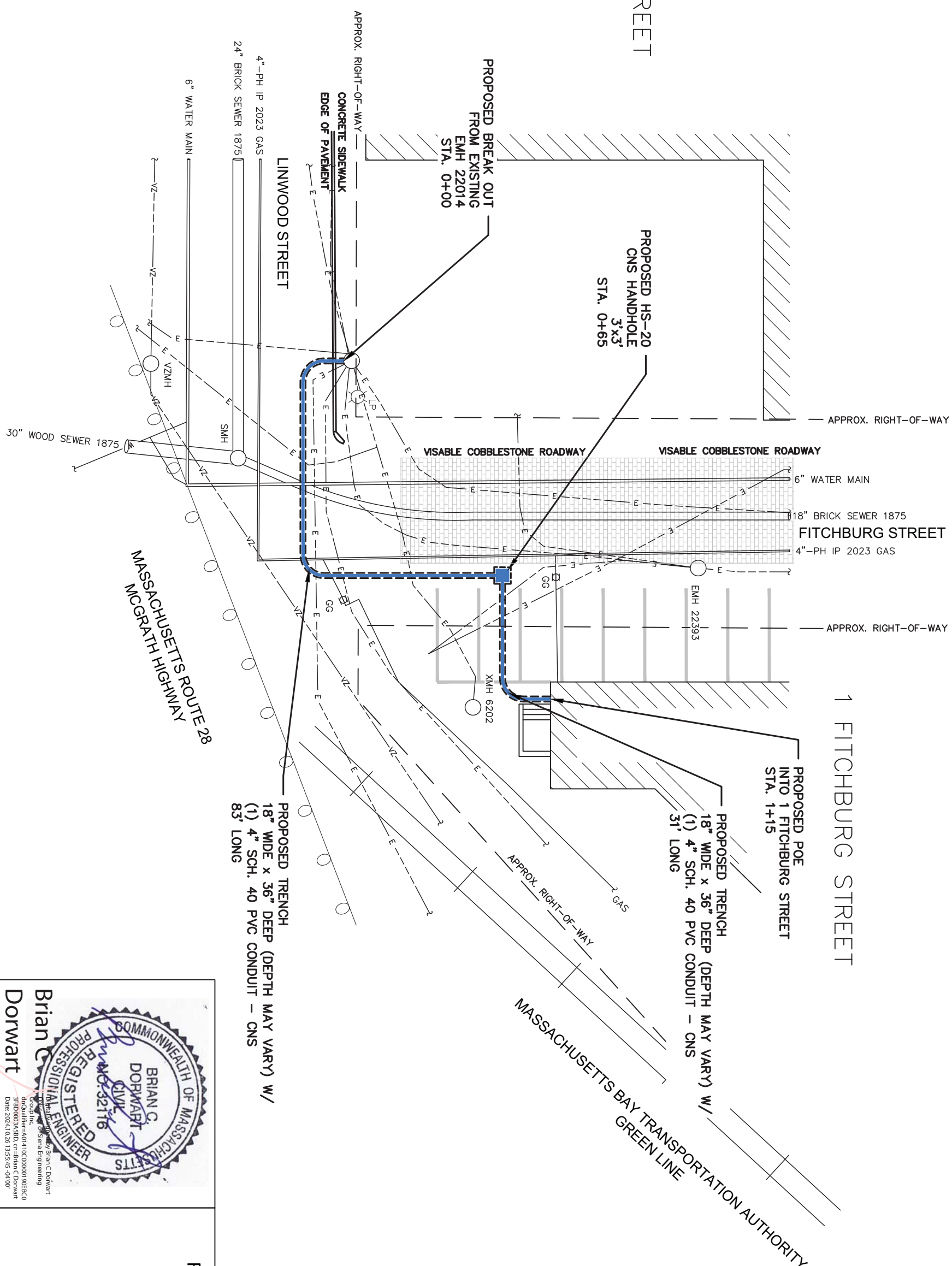

1 FITCHBURG STREET

PROPOSED POE INTO 1 FITCHBURG STREET STA. 1+15

PROPOSED TRENCH 18" WIDE x 36" DEEP (DEPTH MAY VARY) W/ (1) 4" SCH. 40 PVC CONDUIT - CNS 31' LONG

PROPOSED TRENCH 18" WIDE x 36" DEEP (DEPTH MAY VARY) W/ (1) 4" SCH. 40 PVC CONDUIT - CNS 83' LONG

C:\Users\rstoker\AppData\Local\Temp\AcPublish\_20080\24-20014\_1 Fitchburg Street.dwg  
 Oct 17, 2024 - 3:53pm by rstoker

Designed by **R. STOKER** Checked by **J. KENNEDY** Date **OCTOBER 17, 2024**

DIVISION ENGINEER \_\_\_\_\_

PROPOSED CONDUIT PLACEMENT PLAN

Scale: 1" = 20'

PREPARED BY:



PREPARED FOR:



CITY OF SOMERVILLE

PUBLIC WORKS DEPARTMENT

SHEET NUMBER:

ENGINEERING DIVISION  
 GRANT OF LOCATION PLAN  
 PROPOSED LATERAL CONDUIT PLACEMENT  
 1 FITCHBURG STREET

**Brian C Dorwart**  
 REGISTERED PROFESSIONAL ENGINEER  
 COMMONWEALTH OF MASSACHUSETTS  
 REG. NO. 32116  
 Exp. 12/31/25  
 Brian C Dorwart  
 1000 State Street  
 Somerville, MA 02143  
 Phone: 617-410-0001  
 Fax: 617-410-0001  
 Email: brian.dorwart@sienaeng.com  
 Date: 2024.10.26 13:55:45 -04'00"

REGISTRY BOX

1

OF 5 SHEETS

**NOTE:**  
 DEPTH SHALL VARY BASED UPON ENCOUNTERS WITH EXISTING UTILITIES.  
 CONTRACTOR SHALL MAINTAIN A MINIMUM OF 24" DEPTH OF COVER.  
 IF 24" MINIMUM DEPTH OF COVER CANNOT BE ACHIEVED, CONSULT W/  
 ENGINEER.  
 TRENCH WIDTH DIMENSIONS SHOWN FOR CLARITY, ACTUAL WIDTH WILL  
 DEPEND ON FIELD CONDITIONS.

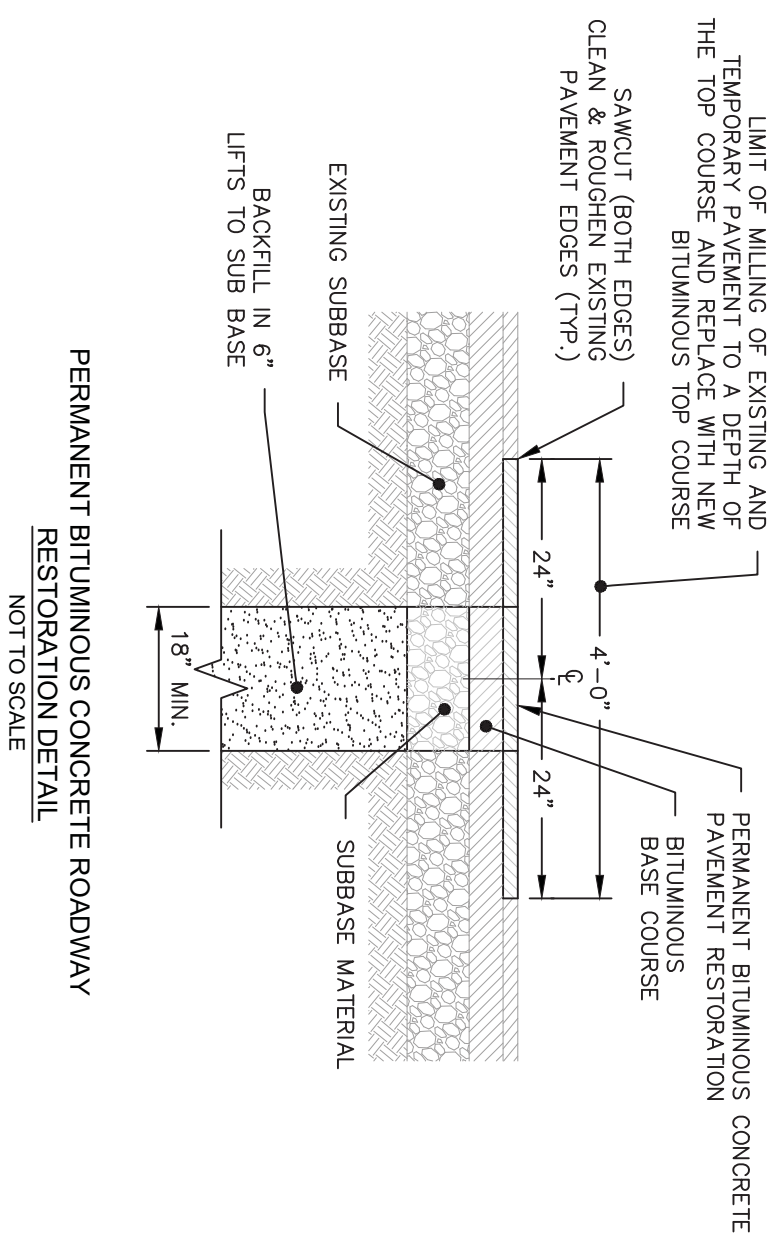
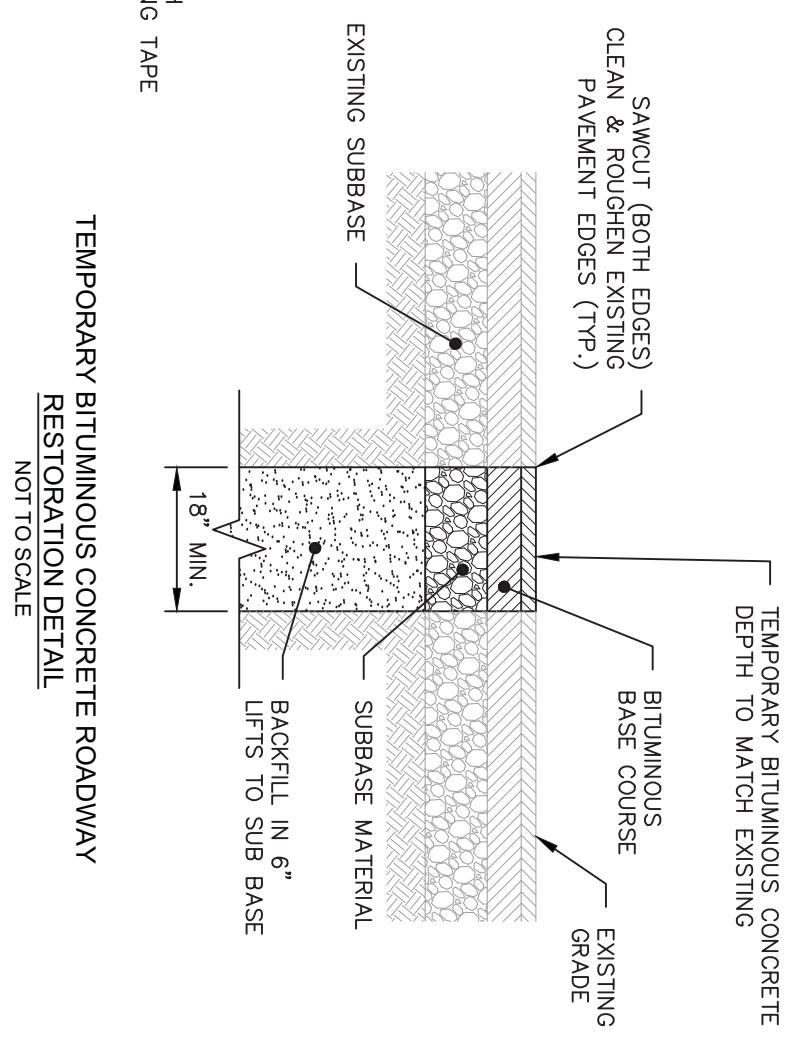
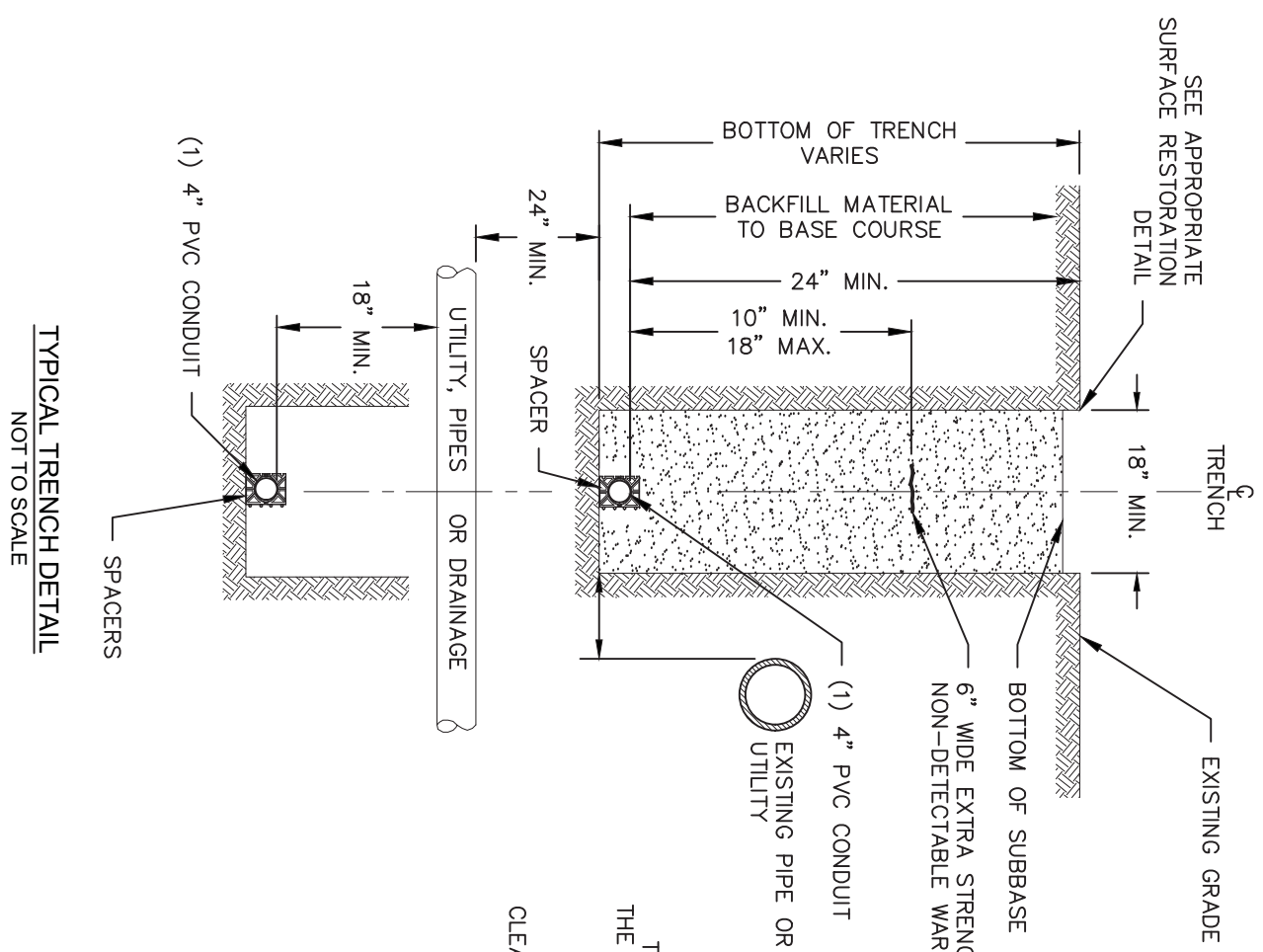

K:\Projects\24-20014 1 Fitchburg St Somerville, MA CNS\6\_CAD\DWG\24-20014 1 Fitchburg Street.dwg  
 Oct. 17, 2024 - 3:54pm by reticker

Designed by **R. STOKER** Checked by **J. KENNEDY** Date **OCTOBER 17, 2024**

Scale: **AS NOTED** **DETAIL SHEET**

PREPARED BY:



PREPARED FOR:



CITY OF SOMERVILLE PUBLIC WORKS DEPARTMENT

ENGINEERING DIVISION  
 GRANT OF LOCATION PLAN

PROPOSED LATERAL CONDUIT PLACEMENT  
 1 FITCHBURG STREET



Brian C. Dorwart  
 Dorwart  
 Inc.  
 1000 Washington Street, Suite 200  
 Somerville, MA 02143  
 Phone: 617.221.7117  
 Fax: 617.221.7117  
 Date: 2024.10.28 15:55:53 04/00

REGISTRY BOX

SHEET NUMBER:

**2**

OF 5 SHEETS

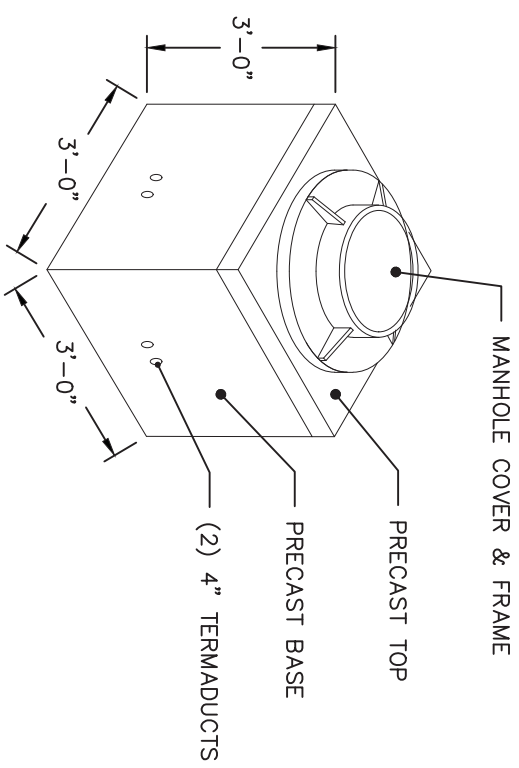

**CONCRETE HS-20 RATED CAMBRIDGE NETWORK SOLUTIONS (CNS)  
HANDHOLE DETAIL - 3'x3'x3'**  
NOT TO SCALE

- NOTES:**
- HANDHOLES INSTALLED IN ACCORDANCE WITH THE LATEST REVISION OF CAMBRIDGE NETWORK SOLUTIONS (CNS) STANDARD SPECIFICATIONS FOR OUTSIDE PLANT CABLE CONSTRUCTION AND REMOVAL.
  - CONCRETE COMPRESSIVE STRENGTH = 5,000 PSI. VAULT IS DESIGNED TO MEET ASTM C857 AND ACI 318 WITH AASHTO HS-20 LOADING
  - CONSTRUCTION JOINT SEALED WITH 1" DIA. BUTYL RUBBER OR ENGINEER APPROVED EQUAL.
  - MANHOLE RACKING CONFORMS WITH CAMBRIDGE NETWORK SOLUTIONS (CNS) SPECIFICATIONS.
  - MANHOLE MANUFACTURED BY OLDCASTLE PRECAST, UTILITY MANHOLE MH3X3X30B

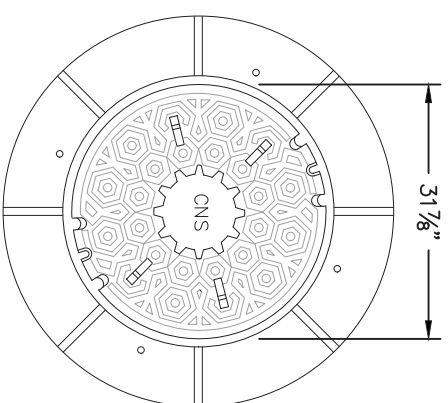

- NOTES:**
- COVER COMPLIES WITH AASHTO HS-20 LOAD RATINGS FOR PLACEMENT IN ROADWAYS.
  - COVER INSTALLED IN ACCORDANCE WITH THE LATEST REVISION OF CAMBRIDGE NETWORK SOLUTIONS (CNS) STANDARD SPECIFICATIONS FOR OUTSIDE PLANT CABLE CONSTRUCTION AND REMOVAL.
  - COVER AND FRAME PROPERLY ALIGNED AND FREE OF DIRT AND STONES WHEN JOINED.

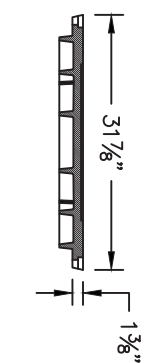

**FRAME & STANDARD CAMBRIDGE NETWORK SOLUTIONS (CNS)  
COVER ASSEMBLY DETAIL**  
NOT TO SCALE

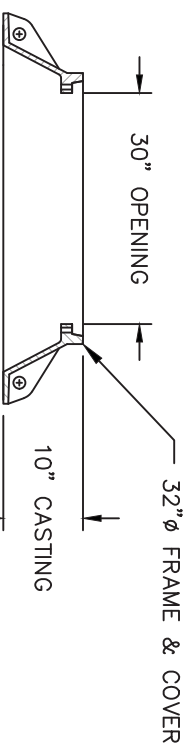

REGISTRY BOX



CITY OF SOMERVILLE  
ENGINEERING DIVISION  
GRANT OF LOCATION PLAN

PUBLIC WORKS DEPARTMENT

PREPARED BY:

PREPARED FOR:



PROPOSED LATERAL CONDUIT PLACEMENT  
1 FITCHBURG STREET

SHEET NUMBER:

3

OF 5 SHEETS

C:\Users\ystoker\AppData\Local\Temp\AcPublish\_20080\24-20014\_1 Fitchburg Street.dwg  
Oct 17, 2024 - 3:53pm by rstoker

Designed by **R. STOKER**  
Checked by **J. KENNEDY**  
Date **OCTOBER 17, 2024**

Scale:  
**AS NOTED**

**DETAIL SHEET**

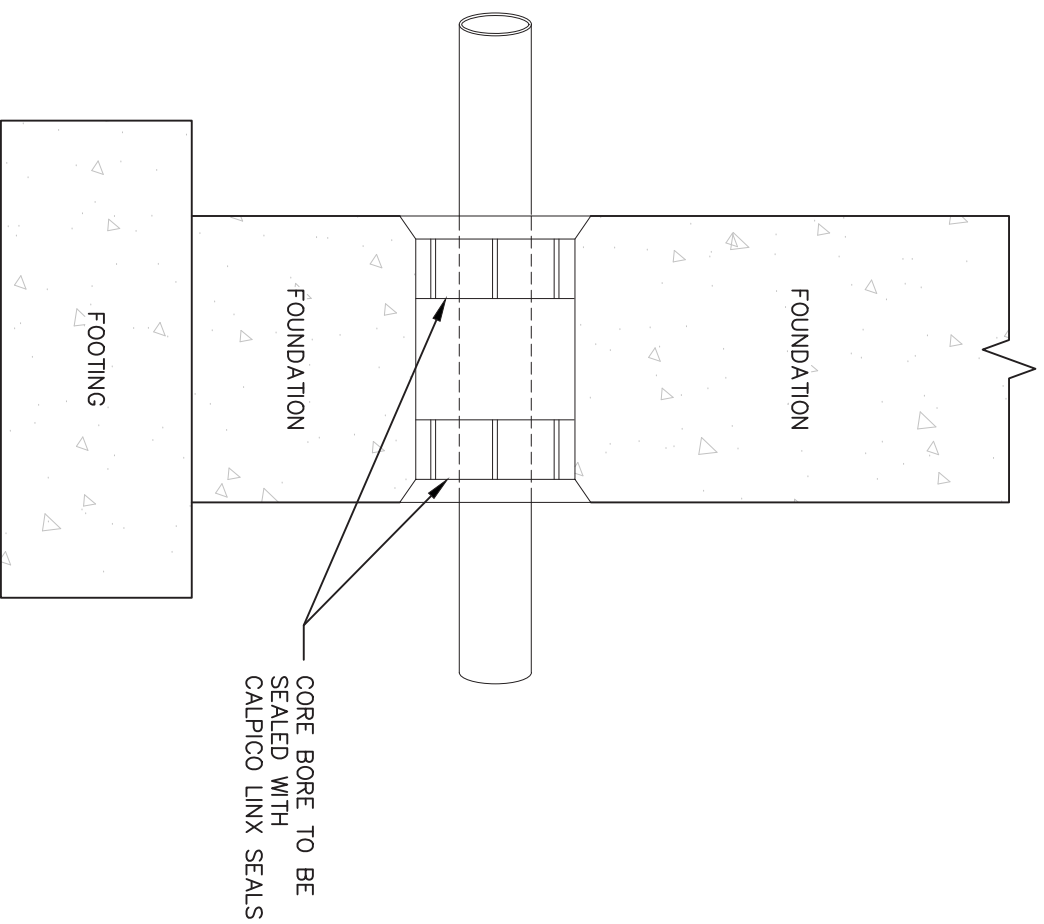

**BUILDING ENTRANCE DETAIL**  
**DETAIL "B"**  
 NOT TO SCALE

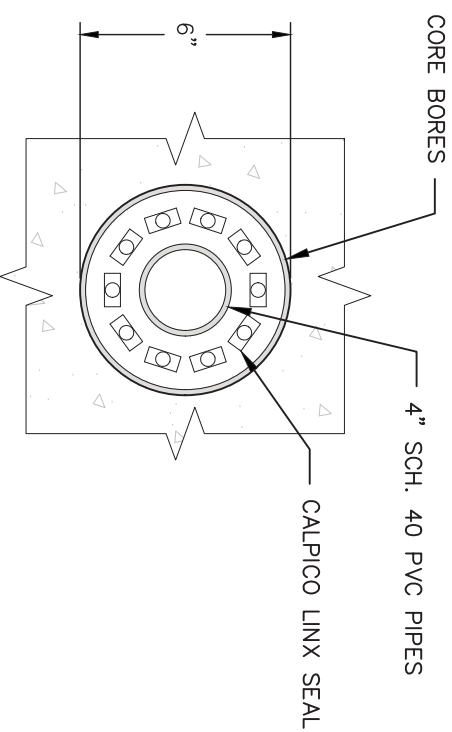

**CORE BORE - FRONT VIEW**  
**DETAIL "A"**  
 NOT TO SCALE

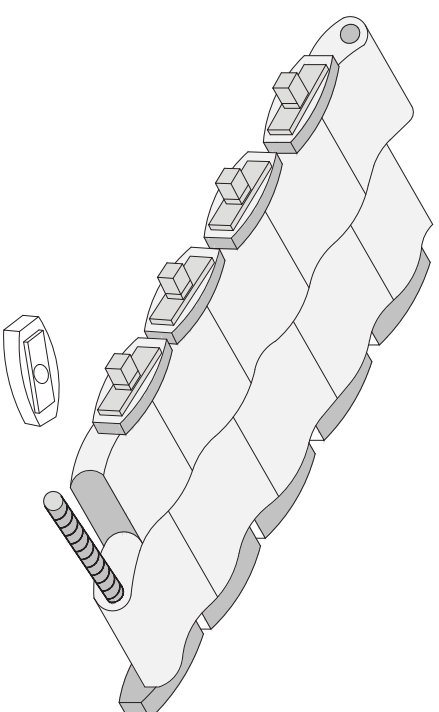

**CALPICO LINX PRIOR TO TIGHTENING**  
**DETAIL "C"**  
 NOT TO SCALE

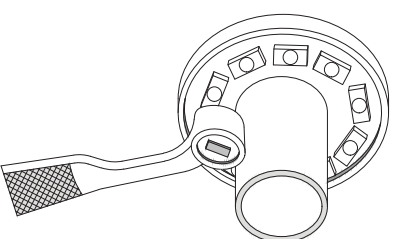

**TIGHTENING TO FORM AIRTIGHT & WATERTIGHT SEAL**  
**DETAIL "D"**  
 NOT TO SCALE

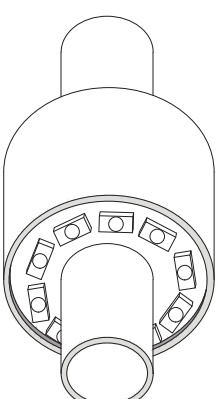

**CALPICO LINX INSTALLATION COMPLETE**  
**DETAIL "E"**  
 NOT TO SCALE

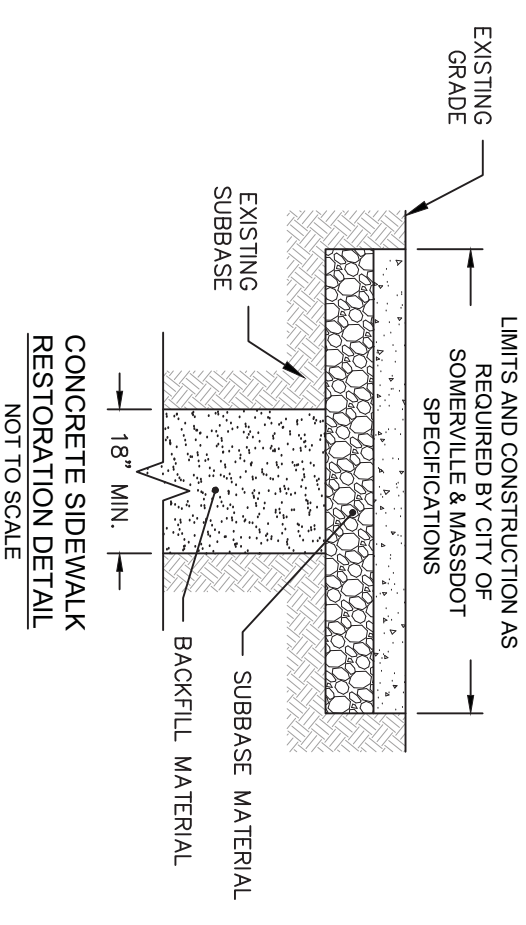

**CONCRETE SIDEWALK RESTORATION DETAIL**  
 NOT TO SCALE

C:\Users\rstoker\AppData\Local\Temp\AcPublish\_20080\24--20014\_1 Fitchburg Street.dwg  
 Oct 17, 2024 - 3:53pm by rstoker

Designed by **R. STOKER** Checked by **J. KENNEDY** Date **OCTOBER 17, 2024**

Scale:  
**AS NOTED**

**DETAIL SHEET**

PREPARED BY:



PREPARED FOR:



**Brian C. Dorwart**  
 REGISTERED PROFESSIONAL ENGINEER  
 COMMONWEALTH OF MASSACHUSETTS  
 License No. 32116  
 Date: 2024.10.26 13:52:28 -0400

**REGISTRY BOX**

CITY OF SOMERVILLE

PUBLIC WORKS DEPARTMENT

SHEET NUMBER:

ENGINEERING DIVISION  
 GRANT OF LOCATION PLAN

































**PROPOSED LATERAL CONDUIT PLACEMENT**  
 1 FITCHBURG STREET

**4**











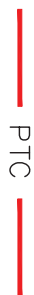

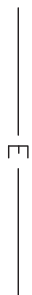

OF 5 SHEETS



## SYMBOLS

	PROPOSED MANHOLE		PS	PEDESTRIAN SIGNAL
	PROPOSED HANDHOLE		SMH	SEWER MANHOLE
	SOMERVILLE WATER WORKS HANDHOLE		STMH	STEAM MANHOLE
	CATCH BASIN		SLMH	STREET LIGHT MANHOLE
	DEPTH OF CABLE NOTE		SIGN	SIGN
	DRAIN MANHOLE		TMH	TELEPHONE MANHOLE
	ELECTRIC MANHOLE		TELHH	TELEPHONE HANDHOLE
	ELECTRIC HANDHOLE		THH	TRAFFIC HANDHOLE
	FIRE ALARM PULL BOX			TRAFFIC MAST ARM
	GAS MANHOLE		TSCC	TRAFFIC SIGNAL CONTROL CABINET
	GAS METER		TS	TRAFFIC SIGNAL
	GAS GATE			TREE
	GUARD POST (BOLLARD)		UP	UTILITY POLE
	HPFS MH		WG	WATER GATE
	HYDRANT		WM	WATER METER
	LP			
	PM			

## LINETYPES - SIZE UNKNOWN

	PROPOSED CONDUIT
	PTC
	PIPE TYPE CABLE (HIGH VOLTAGE ELEC)
	CS
	COMBINED SEWER LINE
	CURBING (TYPE)
	TV
	D
	E
	X
	G
	OHW
	S
	ST
	T
	W

## ABBREVIATIONS

(ABAN)	ABANDONED
B/P	BEANPOLE
BIT CONC	BITUMINOUS CONCRETE
CIP	CAST IRON PIPE
CLF	CHAIN LINK FENCE
CONC	CONCRETE
ELEC	ELECTRIC
FND	FOUND
GRAN	GRANITE
HCAP	HANDICAP
LST	LANDSCAPE TIMBER
N/F	NOW OR FORMERLY
PK	PK NAIL
PVC	POLYVINYL CHLORIDE
(R)	RECORD
SW	SIDEWALK
STK/TK	STAKE/TACK
SB/DH	STONE BOUND/DRILL HOLE
W/	WITH

## NOTES

- SUBSURFACE UTILITY LINES, AS SHOWN HEREON, WERE COMPILED ACCORDING TO AVAILABLE RECORD INFORMATION FROM THE REFERENCED COMPANIES AND PUBLIC AGENCIES, AND THEIR LOCATIONS ARE APPROXIMATE ONLY. ACTUAL LOCATIONS MUST BE DETERMINED IN THE FIELD. SIENA ENGINEERING GROUP ASSUMES NO RESPONSIBILITY FOR DAMAGES INCURRED AS A RESULT OF UTILITIES OMITTED OR INACCURATELY SHOWN.
- PROPERTY OWNERS AND PARCEL IDENTIFIERS ARE ACCORDING TO THE CITY OF SOMERVILLE ASSESSORS ON-LINE PARCEL DATA, WWW.CITYOFSOMERVILLE.GOV
- ALL WORK SHALL CONFORM TO CITY OF SOMERVILLE SPECIFICATIONS, AS WELL AS, CONSTRUCTION DETAILS, INCLUDING MATERIALS AND CONSTRUCTION METHODS.

## REFERENCES

- WATER INFORMATION PER DPW WATER AND SEWER PLANS, SCALE 1"=100'.
- SEWER INFORMATION PER MWRA WATER AND SEWER PLANS, SCALE 1"=100'.
- ELECTRIC INFORMATION PER EVERSOURCE ENERGY RECORD UTILITY PLANS.
- GAS INFORMATION PER NATIONAL GRID RECORD UTILITY PLAN, SHEET.
- TELECOMM INFORMATION PER RECORD PLANS RECEIVED FROM VERIZON, COMCAST, AT&T & TCG.

## REGISTRY BOX



CITY OF SOMERVILLE  
ENGINEERING DIVISION  
GRANT OF LOCATION PLAN  
PROPOSED LATERAL CONDUIT PLACEMENT  
1 FITCHBURG STREET

PUBLIC WORKS DEPARTMENT

SHEET NUMBER:

Designed by **R. STOKER**  
Checked by **J. KENNEDY**  
Date **OCTOBER 17, 2024**

### LEGEND & NOTES

PREPARED BY:



PREPARED FOR:



PROPOSED LATERAL CONDUIT PLACEMENT  
1 FITCHBURG STREET

ALEPEDIS EFHARIS  
8 EAST CONCORD ST  
BOSTON, MA 02118 USA

ARNEY ROBERT M.  
1 FITCHBURG ST #C107  
SOMERVILLE, MA 02143 USA

ASHER JOHANNA S & ROBERT D  
TRUSTEES  
1010 WALTHAM ST APT 406  
LEXINGTON, MA 02421

ASSOCIATION BRICKBOTTOM ARTIST  
1 FITCHBURG ST C111  
SOMERVILLE, MA 02143 USA

AVERY MARGUERITE B  
831 S. FLORES ST #3212  
SAN ANTONIO, TX 78204

BAND ELLEN G  
1 FITCHBURG ST #B152  
SOMERVILLE, MA 02143 USA

BAPST SARAH  
20 CONCORD AVE #3  
CAMBRIDGE, MA 02138 USA

BELBUSTI VIVIANA M  
1 FITCHBURG ST C310  
SOMERVILLE, MA 02143

BERMANN ANN  
9 M ST  
HULL, MA 02045 USA

BORTHWICK BONNIE A  
1 FITCHBURG ST #B159  
SOMERVILLE, MA 02143 USA

BRADSHAW ELLIOTT & ROBIN  
1 FITCHBURG ST B553  
SOMERVILLE, MA 02143

BRICKBOTTOM ARTISTS ASSN  
1 FITCHBURG ST UNIT B551  
SOMERVILLE, MA 02143 USA

BRICKBOTTOM C422 LLC  
PO BOX 174  
DOVER, MA 02030

BRICKBOTTOM HOLDINGS LLC  
15 FOLLEN STREET  
CAMBRIDGE, MA 02138

BRISBOIS LANCE R & LEVEILLE ADAM M  
J  
1 FITCHBURG ST #307  
SOMERVILLE, MA 02143

BRODY PAULA & ALAN  
1 FITCHBURG ST #B155  
SOMERVILLE, MA 02143 USA

BROWNE DUNCAN H  
1 FITCHBURG ST #B160  
SOMERVILLE, MA 02143 USA

BUENO RAMON A & WEISBERG DEBRA E  
TRSTEES  
1 FITCHBURG ST #B550  
SOMERVILLE, MA 02143 USA

BUSCH LEE F  
1 FITCHBURG ST C-509  
SOMERVILLE, MA 02143 USA

CAMIEL STUART  
22416 98TH AVE W  
EDMONDS, WA 98020 USA

CAMIEL STUART ARTHUR & SVETLANA  
1 FITCHBURG ST #B453  
SOMERVILLE, MA 02143 USA

CAMPBELL DAVID P.  
1 FITCHBURG ST C416  
SOMERVILLE, MA 02143 USA

CASSIDY GRACE CATHERINE  
1 FITCHBURG ST UNIT C300  
SOMERVILLE, MA 02143

CELIA GILBERT 1980 REVOCABLE TR  
15 GRAY GARDENS WEST  
CAMBRIDGE, MA 02138 USA

CHANG KATHERINE  
1 FITCHBURG ST #C516  
SOMERVILLE, MA 02143 USA

CHEEK DANIEL W  
1 FITCHBURG ST UNIT C119  
SOMERVILLE, MA 02143

CHEEK DANIEL W  
1 FITCHBURG ST #B354  
SOMERVILLE, MA 02143 USA

CHEEK RICHARD W & ELIZABETH U  
4 PEQUOSETTE RD  
BELMONT, MA 02478 USA

CHEN LUCY N  
1 FITCHBURG ST #C105  
SOMERVILLE, MA 02143 USA

CHEW PRISCILLA  
1 FITCHBURG ST #C400  
SOMERVILLE, MA 02143

COLOMBO DAVID  
1 FITCHBURG ST C317  
SOMERVILLE, MA 02143

COLVARD CHICO DAVID  
1 FITCHBURG ST UNIT B350  
SOMERVILLE, MA 02143

CONNELLY CATHERINE M  
1 FITCHBURG ST UNIT 253  
SOMERVILLE, MA 02143

CONNELLY CATHERINE M  
1 FITCHBURG ST C318  
SOMERVILLE, MA 02143

CORDELL DON J J TRUSTEE  
241 PERKINS ST UNIT C103  
JAMAICA PLAIN, MA 02130

COUNTOURIS PAULA M & FEITLER ISAAC  
B  
1 FITCHBURG ST UNIT C512  
SOMERVILLE, MA 02143

CUTLER PETER  
PO BOX 908  
SEDONA, AZ 86339 USA

DACEY MICHAEL L  
1 FITCHBURG ST  
SOMERVILLE, MA 02143

DAVIDSON DEBORAH  
1 FITCHBURG ST #C104B  
SOMERVILLE, MA 02143

DESMOND KATHLEEN  
PO BOX 410177  
CAMBRIDGE, MA 02141

DEVLIN THOMAS E  
1 FITCHBURG ST C305  
SOMERVILLE, MA 02143 USA

DIBONA DAMIEN  
1 FITCHBURG ST #B255  
SOMERVILLE, MA 02143 USA

DURAND KEITH V & NELTNER BRIAN T  
1 FITCHBURG ST UNIT B154  
SOMERVILLE, MA 02143

EASTMENT AMY SARAH  
1 FITCHBURG ST C113  
SOMERVILLE, MA 02143

ERIN E SCHEFFLER  
1 FITCHBURG ST UNIT C-401  
SOMERVILLE, MA 02143

ESPY ANTHONY W  
1 FITCHBURG ST C201  
SOMERVILLE, MA 02143 USA

EWEN PHYLLIS  
1 FITCHBURG ST #C103  
SOMERVILLE, MA 02143 USA

FELD LAURA  
2115 OLEANDER ST  
BATON ROUGE, LA 70806 USA

FELICE JAMES XAVIER  
1 FITCHBURG ST UNIT C104C  
SOMERVILLE, MA 02143 USA

FICHMAN EYTAN  
1 FITCHBURG ST #B150  
SOMERVILLE, MA 02143 USA

FILIMON DAVID J &  
1 FITCHBURG ST #C309  
SOMERVILLE, MA 02143 USA

FINE NORMAN  
1 FITCHBURG ST C-311  
SOMERVILLE, MA 02143

FINNEY DAVID R & CYNTHIA C  
1 FITCHBURG ST  
SOMERVILLE, MA 02143

FIORE LOIS F  
1 FITCHBURG ST #C204  
SOMERVILLE, MA 02143 USA

FIORE LOIS F  
1 FITCHBURG ST C204  
SOMERVILLE, MA 02143 USA

FORRESTER SHANNON  
1 FITCHBURG ST #B552  
SOMERVILLE, MA 02143

FORTE MARJORIE S  
1 FITCHBURG ST #C412  
SOMERVILLE, MA 02143 USA

FREED DEBORAH L  
18 LINWOOD ST  
ARLINGTON, MA 02474 USA

GABIN GEORGE & STONE MARTHA TRS  
1 FITCHBURG ST UNIT B554  
SOMERVILLE, MA 02143 USA

GARRETT CYNTHIA MAURICE TRUSTEE  
1 FITCHBURG ST UNIT C323  
SOMERVILLE, MA 02143

GILBERT JOHN & LEITER VALERIE  
1 FITCHBURG ST UNIT C-207  
SOMERVILLE, MA 02143

GILBERT WALTER & CELIA TRSTEEES  
15 GRAY GARDENS WEST  
CAMBRIDGE, MA 02138 USA

GIPPETTI LOUIS  
1 FITCTCHBURG ST #B358  
SOMERVILLE, MA 02143 USA

GLENN PAUL & RALSTON DAVID  
1 FITCHBURG ST UNIT C-408  
SOMERVILLE, MA 02143

GOLDBERG MARSHA  
451 S FIFTH AVE  
HIGHLAND PARK, NJ 08904 USA

GOODNOW ELIZABETH ADALE  
1 FITCHBURG ST UNIT C517  
SOMERVILLE, MA 02143 USA

GORDON LISA J  
1 FITCHBURG ST #C509  
SOMERVILLE, MA 02143 USA

GOSS ROBERT H & SCHMIDT SUSAN P  
TRSTEEES  
1 FITCHBURG ST #B452  
SOMERVILLE, MA 02143 USA

GUSTAFSON PIER  
1 FITCHBURG ST #B352  
SOMERVILLE, MA 02143 USA

HALL JESSICA  
320 BROADWAY 45101  
SOMERVILLE, MA 02145

HALL JESSICA  
320 BROADWAY 45101  
SOMERVILLE, MA 02145

HALL JESSICA  
1 FITCHBURG ST UNIT C302  
SOMERVILLE, MA 02143

HAMLEN MARGERY M  
250 BEACON ST APT# 14  
BOSTON, MA 02116 USA

HERMANN LANA  
1 FITCHBURG ST UNIT B158  
SOMERVILLE, MA 02143 USA

HOLTZMAN DANIEL  
1 FITCHBURG ST UNIT C-504  
SOMERVILLE, MA 02143

HOLTZMAN KAREN  
1 FITCHBURG ST #C523  
SOMERVILLE, MA 02143 USA

IRWIN LINDA  
1 FITCHBURG ST #C419  
SOMERVILLE, MA 02143

JAMES A KILEY COMPANY  
15 LINWOOD ST  
SOMERVILLE, MA 02143 USA

JOHNSEN ROGER S  
1 FITCHBURG ST #B356  
SOMERVILLE, MA 02143

KAMITAKI TADASHI L  
1 FITCHBURG ST UNIT B450  
SOMERVILLE, MA 02143

KAPLAN CHARLOTTE B  
1 FITCHBURG ST #C521  
SOMERVILLE, MA 02143 USA

KASSEL ROBERT H  
1 FITCHBURG ST UNIT C420  
SOMERVILLE, MA 02143 USA

KENNEDY TERENCE OM ARTISTS  
15A RED GATE LANE  
MEREDITH, NH 03253 USA

KIPP WILLIAM B.  
1 FITCHBURG ST #C211  
SOMERVILLE, MA 02143 USA

KIPP WILLIAM B  
ONE FITCHBURG ST #C211  
SOMERVILLE, MA 02143 USA

LAINOFF JEROME & SYLVIE VINCENT  
1 FITCHBURG ST U-C120  
SOMERVILLE, MA 02143 USA

LEE CHUNG  
33 THIRD STREET  
MEDFORD, MA 02155

LEE SOO HEE  
1 FITCHBURG ST UNIT C-316  
SOMERVILLE, MA 02143

LIM PAULINE  
1 FITCHBURG ST #C414  
SOMERVILLE, MA 02143 USA

LOBEL SELMA & MARTIN  
73 JASON STREET  
ARLINGTON, MA 02476

LOWRY TRAVIS & BIRGER NINA  
1 FITCHBURG ST UNIT C315  
SOMERVILLE, MA 02143

LYGA PATRICIA M & CANAVINO KAY  
56 LAUREL ST  
NORTHAMPTON, MA 01060 USA

MAHONEY ALICE A TRUSTEE  
1 FITCHBURG ST C118B  
SOMERVILLE, MA 02143 USA

MANASTER BETH Z  
4102 SW MONROE ST  
SEATTLE, WA 98136

MARQUEZ PETER J &  
1 FITCHBURG ST UNIT B151  
SOMERVILLE, MA 02143 USA

MCDOWELL JONATHAN  
1 FITCHBURG ST #C205  
SOMERVILLE, MA 02143 02143

MCFEDRIES AMANDA  
1 FITCHBURG ST UNIT C515  
SOMERVILLE, MA 02143

MCGRORY JENNIFER A  
1 FITCHBURG ST #C411  
SOMERVILLE, MA 02143

MEJIA JOSEPH RAPHAEL  
1 FITCHBURG ST UNIT B153  
SOMERVILLE, MA 02143

MESARCH CHRISTINE  
1 FITCHBURG ST #C306  
SOMERVILLE, MA 02143 USA

MIHAJLOVIC STANA  
1 FITCHBURG ST C-122A  
SOMERVILLE, MA 02143 USA

MUNN KATHERINE T  
1 FITCHBURG ST UNIT C410  
SOMERVILLE, MA 02143 USA

NOVETSKY DIANE  
1 FITCHBURG ST #C213  
SOMERVILLE, MA 02143 USA

OLIN DEBRA & GOULET LINDA M  
1 FITCHBURG ST #C301  
SOMERVILLE, MA 02143

ORLOW DANIEL L  
1 FITCHBURG ST #C404  
SOMERVILLE, MA 02143 USA

PAPPAS MARILYN  
1 FITCHBURG ST C415  
SOMERVILLE, MA 02143 USA

PAPPAS MARILYN R  
1 FITCHBURG ST C511  
SOMERVILLE, MA 02143

PEARCE HENRY W  
1 FITCHBURG ST UNIT C 210  
SOMERVILLE, MA 02143

PERKINS SUSAN  
2130 OWLS COVE LANE  
RESTON, VA 20191

PODREN MARTHA  
1 FITCHBURG ST C117  
SOMERVILLE, MA 02143

POISSON D TIMOTHY  
1 FITCHBURG ST C-500  
SOMERVILLE, MA 02143

POLUMBAUM MINI ANN  
1 FITCHBURG ST C406  
SOMERVILLE, MA 02143 USA

POOK POLLY K  
1 FITCHBURG ST #C222  
SOMERVILLE, MA 02143 USA

POWNALL JAY RONALD  
1 FITCHBURG ST UNIT 104E  
SOMERVILLE, MA 02143 USA

POWNALL JAY RONALD  
1 FITCHBURG ST UNIT 104E  
SOMERVILLE, MA 02143 USA

PURCELL ROSAMOND WOLFF  
121 ALLSTON ST  
MEDFORD, MA 02155 USA

REANIMATION STUDIOS LLC  
1 FITCHBURG ST C509  
SOMERVILLE, MA 02143

REANIMATION STUDIOS LLC  
1 FITCHBURG ST UNITC509  
SOMERVILLE, MA 02143

REGAN FELICE  
1 FITCHBURG ST #C303  
SOMERVILLE, MA 02143 USA

REID MCMAHON THOMAS  
1 FITCHBURG ST #C-208  
SOMERVILLE, MA 02143

REINER DANIEL B TRUSTEE  
1 FITCHBURG ST UNIT 407C  
SOMERVILLE, MA 02143 USA

RIPLEY ROSEMARY  
1 FITCHBURG ST UNIT C-212  
SOMERVILLE, MA 02143

ROGER STEPHEN  
1 FITCHBURG ST UNIT C-522  
SOMERVILLE, MA 02143

SATO SHUJI  
15 HARRISON ROAD  
SOMERVILLE, MA 02144

SCHMAHMANN KIM & ORLIKOWSKI  
WANDA  
1 FITCHBURG ST #B156  
SOMERVILLE, MA 02143

SCHULMAN BARBARA  
PO BOX 150483  
BROOKLYN, NY 11215 USA

SHEPLEY JULIA A.  
1 FITCHBURG ST #C312  
SOMERVILLE, MA 02143 USA

SHULTZ HARVEY A TRUSTEE  
2 CONTRA WAY T3'S - J RICHMAN  
MERRIMACK, NH 03054

SIMMONS HENRIKE ANNE  
1 FITCHBURG ST #B355  
SOMERVILLE, MA 02143

SIMONIS OBIE B & JACQUELINE  
1 FITCHBURG ST #F191  
SOMERVILLE, MA 02143 USA

SMITH ADELAIDE S  
1 FITCHBURG ST #C220  
SOMERVILLE, MA 02143 USA

SNODGRASS KATHERINE  
1 FITCHBURG ST #C508  
SOMERVILLE, MA 02143 USA

SOMERVILLE HOUSING AUTH  
30 MEMORIAL RD  
SOMERVILLE, MA 02145 USA

SPARLING ROBERT  
1 FITCHBURG ST UNIT C519  
SOMERVILLE, MA 02143

SPITZER JUDITH  
1 FITCHBURG ST C-423  
SOMERVILLE, MA 02143 USA

SPIVACK BARNEY  
101 LONG LOTS RD  
WESTPORT, CT 06880 USA

SPRINGER SHIRA A  
25 CHILTON STREET #2  
CAMBRIDGE, MA 02138

STRAUS JESICA  
22 TERRACE AVE  
NEWTON, MA 02461 USA

STRAUSS SUSAN L.  
511 SANFORD RD  
WESTPORT, MA 021790 USA

SUMMERS GEORGE JR.  
1 FITCHBURG ST #C206  
SOMERVILLE, MA 02143 USA

THURSTON RANDAL G.  
1 FITCHBURG ST #C209  
SOMERVILLE, MA 02143 USA

TOFFOLI LUCAS RITZ  
1 FITCHBURG ST #C403  
SOMERVILLE, MA 02143

TOFFOLI TOMMASO  
1 FITCHBURG ST UNIT C118A  
SOMERVILLE, MA 02143

TRUMAN CATHERINE M TRUSTEE  
1 FITCHBURG ST UNIT C109  
SOMERVILLE, MA 02143

TRUMAN CATHERINE M TRUSTEE  
1 FITCHBURG ST UNIT C215  
SOMERVILLE, MA 02143

TRUST BRICKBOTTOM ARTISTS GRE  
1 FITCHBURG ST C303  
SOMERVILLE, MA 02143 USA

TRUST W S COOLEEDGE REALTY  
1 FITCHBURG ST U-C520  
SOMERVILLE, MA 02143 USA

VAN AELST HEATHER  
1 FITCHBURG ST #C304  
SOMERVILLE, MA 02143 USA

WANG HAOXUAN  
1 FITCHBURG ST UNIT B353  
SOMERVILLE, MA 02143

WATKINS LESLIE G  
1 FITCHBURG ST C-518  
SOMERVILLE, MA 02143

WOODBURY MAYA ELLEN & JUDGE  
ROBERT JOHN  
1 FITCHBURG ST UNIT B252  
SOMERVILLE, MA 02143

WRIGHT JAMES M & JOAN H  
1 FITCHBURG ST #C405  
SOMERVILLE, MA 02143 USA

WRIGHT, JAMES M  
1 FITCHBURG ST, UNIT C405  
SOMERVILLE, MA 02143

WYNER JONATHAN ADAM  
1 FITCHBURG ST #C514  
SOMERVILLE, MA 02143

YOUNG ELLEN  
1 FITCHBURG ST #B256  
SOMERVILLE, MA 02143 USA

ZECHA ALDEN & BAKEY C TRUSTEES  
1 FITCHBURG ST UNIT C320  
SOMERVILLE, MA 02143

ZECHA ALDEN D TRUSTEE  
1 FITCHBURG ST UNIT C320  
SOMERVILLE, MA 02143