



CITY OF SOMERVILLE
Commonwealth of Massachusetts
93 Highland Avenue
Somerville, MA 02143
(617) 625-6600

BUSINESS LICENSE APPLICATION - Grant of Location

File #: 24-017408
License #: BL24-000120
Address: 315 BROADWAY
Licensee: Doug Gagnon UC Synergetic (Verizon)
DBA Name: Verizon New England Inc.

Business Ownership Type: Corporation
Legal Name of Entity: Verizon New England Inc.
Owners/Officers: , , ,

License Information:

Grant of location issued to: Verizon New England Inc.

Describe the reason for the work, and the intended beneficiaries: This petition is necessary in order to provide new services.

Insert here the same detailed description of the work as appears in the attached Grant of Location

Order: Place one new four-inch (4") PVC conduit, beginning from existing manhole, MH44/87, extending northwest approximately two hundred and forty-three feet (243') to an existing handhole in front of 315 Broadway.

Approval Conditions:

Approved By:

Isabela Maia, Approved with Conditions

Malik Drayton, Approved with Conditions

APPROVAL CONDITION: MD20240808: Contractor shall take all necessary precautions to avoid damaging any tree or tree part with equipment.

APPROVAL CONDITION: MD20240808: All nearby street tree(s) shall be protected prior to and during all construction activities using TREE BOX or TREE WRAPS. . TREE BOX shall be constructed from 2 in. x 4 in. lumber creating a box around the border of the tree pit with 2 in. x 4 in. lumber standing straight up at the corners and wrapped with orange snow fence. Detail attached. . TREE WRAPS (TREE TRUNK WRAPPING PROTECTION LUMBER) shall consist of 2 in. x 4 in. and 8 ft. height lumber wired together in close spacing with zip ties or 16 gauge galvanized steel wire to form a protective enclosure around tree trunks. Use burlap to separate the wood from the bark if necessary to prevent wood from scraping or bruising bark. Do not use staples or puncture the trunk in any way.

APPROVAL CONDITION: MD20240808: Any tree roots less than two (2) inches in diameter that cannot be avoided during construction shall be carefully and cleanly cut with a clean pair of pruning shears or loppers. Roots are to be cut back flush with the edge of the trench. If any tree roots greater than two (2) inches in diameter are encountered, stop work immediately and contact the City Urban Forester. Any and all pruning of roots greater than 2 inches in diameter must be completed under the supervision of the City Urban Forester.

Jill Lathan, Approved

Kimberly M. Wells, Approved



CITY OF SOMERVILLE, MASSACHUSETTS
CITY CLERK'S OFFICE

KATJANA BALLANTYNE
MAYOR

KIMBERLY M. WELLS
CITY CLERK

August 14, 2024

NOTICE OF PUBLIC HEARING

You are hereby notified that the Somerville City Council will hold a Public Hearing on the following Petition. You are receiving this Notice because the Petitioner has reported that you own property that abuts the work that is being proposed. You and other members of the public are invited to attend and be heard at this Hearing.

This meeting of the City Council will also be conducted via remote participation, online in a webinar hosted on the Zoom platform.

You have three ways to be heard at this meeting:

1. To attend and be heard, enter the link exactly as it appears below into your internet browser any time before the meeting. You will then be asked to register for the meeting. After registering, you will receive an email with instructions to join the webinar when it starts.
2. You may also testify in person in the City Council Chamber, City Hall, 2nd Floor, 93 Highland Avenue, Somerville, MA 02143
3. If you are unable to attend but wish to be heard, you may send written comments by US mail to the City Clerk at the address below, or by email to cityclerk@somervillema.gov. Your comments must arrive no later than 12 Noon on the day of the Hearing, in order to be sure they are conveyed to the Council.

PETITION: Verizon New England Inc. is applying for a Grant of Location to install approximately 243 feet of conduit in Broadway, from existing Manhole 44/87 to an existing handhole in front of 315 Broadway.

PLACE: https://us02web.zoom.us/webinar/register/WN_rTQmfy-RQCG_QqKLjtYHsA or City Council Chambers, City Hall, 2nd Floor, 93 Highland Avenue, Somerville, MA 02143

TIME: Thursday, August 22, 2024, at 7:00 PM.

PURPOSE: The work is necessary to provide new services.

GENERAL NOTES

1. THE LOCATIONS OF EXISTING UNDERGROUND UTILITIES ARE SHOWN IN AN APPROXIMATE WAY ONLY AND HAVE NOT BEEN INDEPENDENTLY VERIFIED BY THE OWNER OR ITS REPRESENTATIVE. THE CONTRACTOR SHALL DETERMINE THE EXACT LOCATION OF ALL EXISTING UTILITIES BEFORE COMMENCING WORK, AND SHALL BE FULLY RESPONSIBLE FOR ANY AND ALL DAMAGES WHICH MIGHT BE OCCASIONED BY THE CONTRACTOR'S FAILURE TO EXACTLY LOCATE AND PRESERVE ANY AND ALL UNDERGROUND UTILITIES.
2. WHERE AN EXISTING UTILITY IS FOUND TO CONFLICT WITH THE PROPOSED WORK, THE LOCATION, ELEVATION AND SIZE OF THE UTILITY SHALL BE ACCURATELY DETERMINED WITHOUT DELAY BY THE CONTRACTOR, AND THE INFORMATION FURNISHED TO THE ENGINEER FOR RESOLUTION OF THE CONFLICT.
3. THE CONTRACTOR SHOULD MAINTAIN A SEPARATION OF 18 INCHES MIN. WHEN CROSSING EXISTING WATER FACILITIES.
4. THE CONTRACTOR SHALL MAKE ALL ARRANGEMENTS FOR THE ALTERATION AND ADJUSTMENT OF GAS, ELECTRIC, TELEPHONE AND ANY OTHER PRIVATE UTILITIES BY THE UTILITY COMPANY.
5. THE CONTRACTOR SHALL NOT DISTURB PUBLIC TREES AND SHRUBS.
6. AREAS OUTSIDE THE LIMITS OF PROPOSED WORK DISTURBED BY THE CONTRACTOR'S OPERATIONS SHALL BE RESTORED BY THE CONTRACTOR TO THEIR ORIGINAL CONDITION AT NO EXPENSE TO THE OWNER.
7. THE CONTRACTOR SHALL BE RESPONSIBLE FOR PLACING AND MAINTAINING TEMPORARY RESURFACING AND/OR PLATING FOR ALL EXCAVATIONS IN PAVED STREETS AND SIDEWALKS UNTIL PERMANENT RESURFACING IS COMPLETE.
8. JOINTS BETWEEN NEW BITUMINOUS CONCRETE ROADWAY PAVEMENT AND SAW CUT EXISTING PAVEMENT SHALL BE SEALED WITH BITUMEN AND BACK SANDED.
9. THE CONTRACTOR SHALL PROTECT AND SUPPORT ALL EXISTING UTILITY LINES THAT BECOME EXPOSED DUE TO EXCAVATION REQUIRED TO INSTALL THE PROPOSED CONDUIT.
10. THE CONTRACTOR SHALL REPLACE ALL DISTURBED TRAFFIC SIGNAL LOOP DETECTORS TO GOOD WORKING CONDITION AS REQUIRED BY THE LATEST STANDARDS OF THE MUNICIPAL TRAFFIC DEPARTMENT.
11. ALL EXISTING STATE, COUNTY, CITY, AND TOWN LOCATION LINES AND PRIVATE PROPERTY LINES HAVE BEEN ESTABLISHED FROM AVAILABLE INFORMATION AND THEIR EXACT LOCATION ARE NOT GUARANTEED.
12. THE CONTRACTOR SHALL REPLACE ALL PAVEMENT MARKINGS IN THEIR ENTIRETY THAT HAVE BEEN DAMAGED BY TRENCH EXCAVATION OR OPERATIONS OF THE CONTRACTOR WITH SIMILAR COLOR AND SIZE THERMOPLASTIC MARKINGS.
13. CITY SHADOW SHOULD BE BROUGHT INTO ALL PROPOSED AND EXISTING MANHOLES/HANDHOLES (I.E. NOT STUBBED SHORT OF ANY STRUCTURES. ALL CITY SHADOW DUCTS SHALL BE TAPED AND TAGGED AS SUCH.

* - ITEM SHOWN ON UTILITY RECORDS, BUT NOT FOUND IN FIELD.
 ~ - ITEM FOUND IN FIELD, BUT NOT IN UTILITY RECORDS.

ALL FIELD DATA ACQUIRED USING TOTAL STATION SURVEY EQUIPMENT

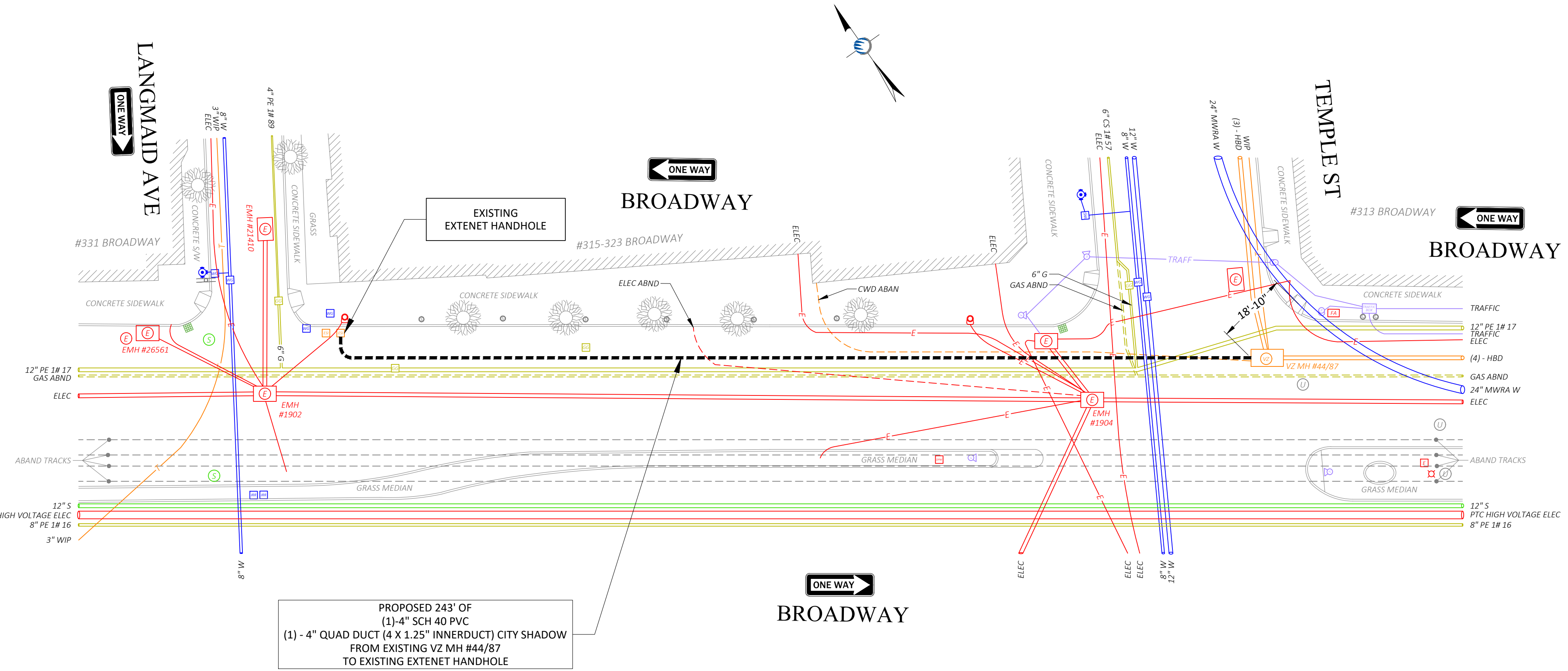

PROPOSED 243' OF
 (1)-4" QUAD DUCT (4 X 1.25" INNERDUCT) CITY SHADOW
 FROM EXISTING VZ MH #44/87
 TO EXISTING EXTENET HANDHOLE

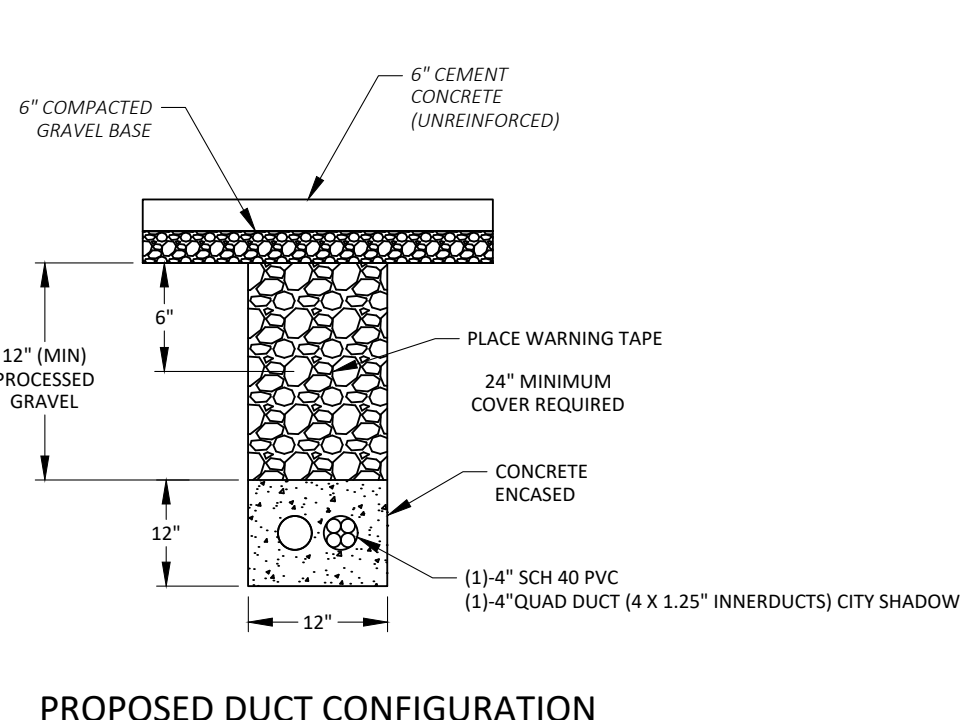
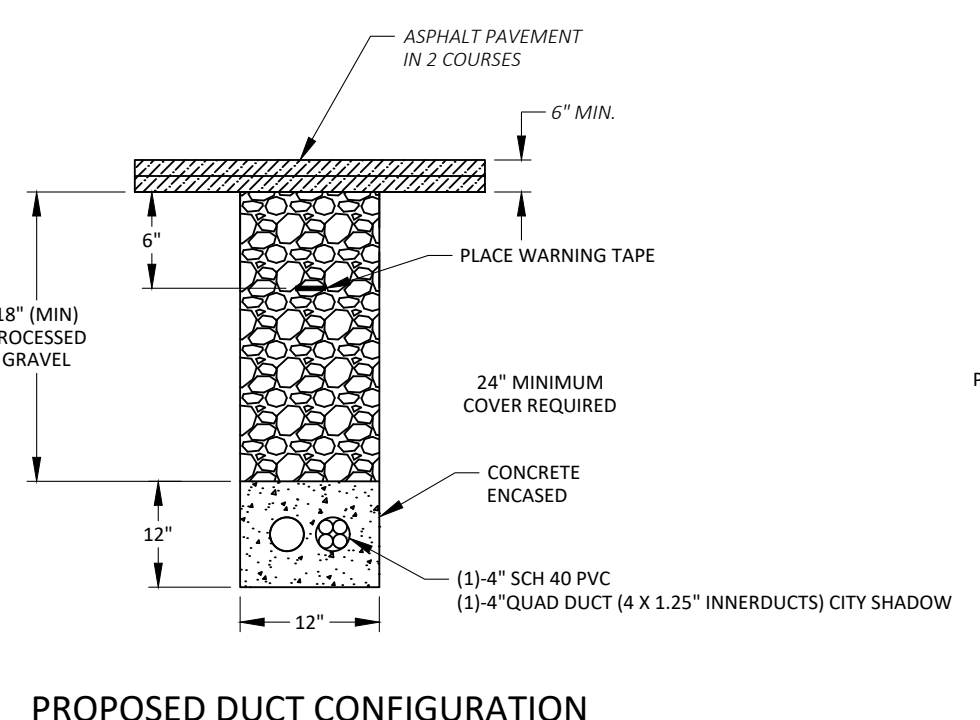
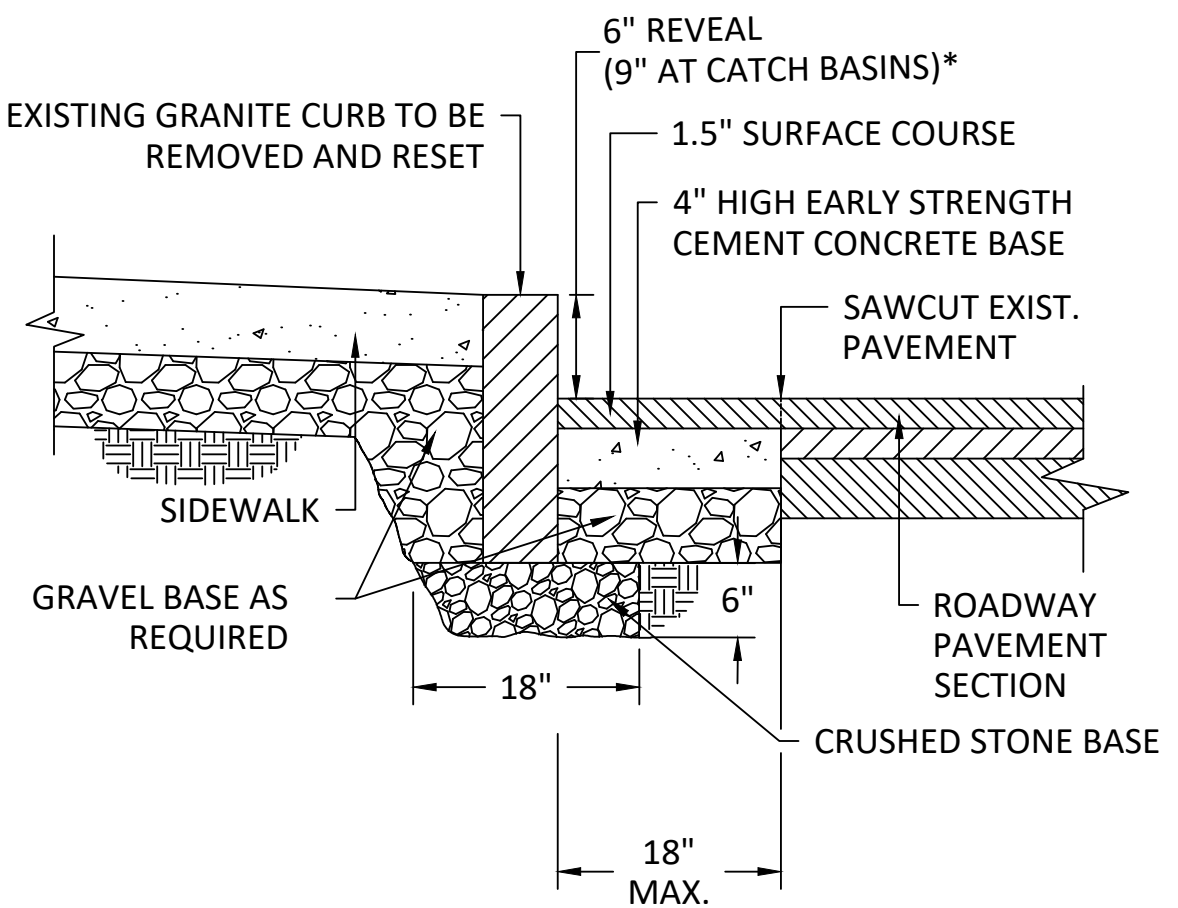

*6" REVEAL TYPICAL. REVEAL MAY VARY FROM 3" TO 9" WITH PWD APPROVAL.

FOR PERMITTING ONLY

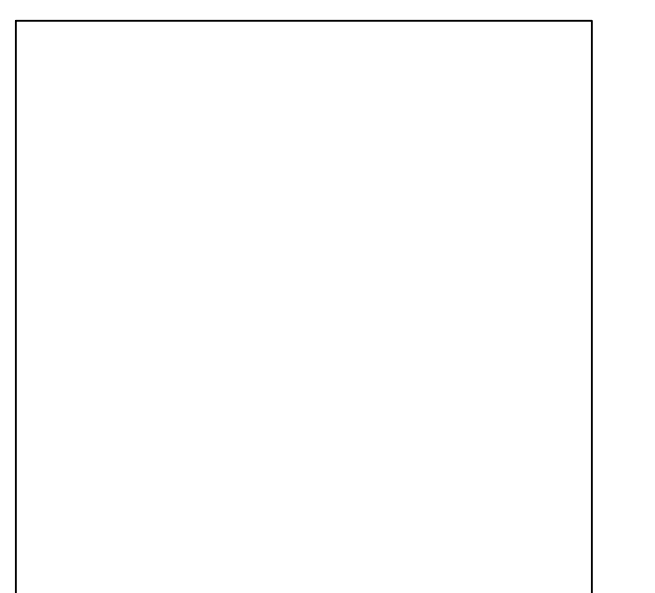

1" = 20 FEET (PRINTED 22X34)
 1" = 40 FEET (PRINTED 11X17)

LEGEND

⊗	ELECTRIC POLE	⊗	CATCH BASIN
⊕	JOINT UTILITY POLE	⊕	CATV HANDHOLE
⊙	LAMP POST	⊙	COMM PEDESTAL
⊚	TRAFFIC LIGHT	⊚	ELECTRIC HANDHOLE
⊛	CATV MANHOLE	⊛	FIRE HYDRANT
⊜	DRAIN MANHOLE	⊜	GAS GATE
⊝	ELECTRIC MANHOLE	⊝	GAS METER
⊞	SEWER MANHOLE	⊞	IRRIGATION VALVE
⊟	TELEPHONE MANHOLE	⊟	MAIL BOX
⊠	WATER MANHOLE	⊠	PARKING METER(S)
⊡	POLE ANCHOR GUY	⊡	SEWER GATE
⊢	BUSH/SHRUB	⊢	SIGN POLE
⊣	R/W	⊣	STEEL POST
⊤	CULVERT	⊤	STONE BOUND
⊥	FENCE	⊥	STREET LIGHT
⊦	GUARD RAIL	⊦	TEL HANDHOLE
⊧	ELECTRIC VAULT	⊧	TRANSFORMER
⊨	TRAFFIC HANDHOLE	⊨	UG CABLE MARKER
⊩	PROPOSED HANDHOLE	⊩	WATER GATE
⊪	PROPOSED CONDUIT	⊪	WATER METER

NOTE:
 EXISTING UTILITIES SHOWN ARE APPROXIMATE AND NOT WARRANTED TO BE CORRECT. THE CONTRACTOR SHALL VERIFY THE LOCATION OF ALL PUBLIC AND PRIVATE UTILITIES PRIOR TO BEGINNING ANY EXCAVATION.

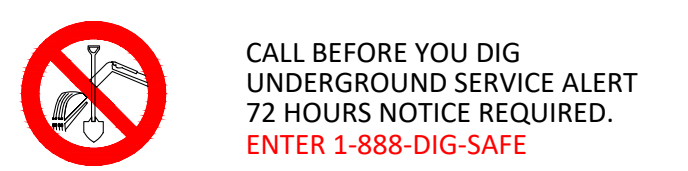

PREPARED BY:
PIKE TELECOM
 21 Oxford Rd
 Mansfield, MA 02048
 www.piketelecom.org
 1-508-337-7600

PREPARED FOR:
verizon

REV #	DESCRIPTION	DATE

TITLE:
ROW 144TC4T WPI 2666016 - 315 BROADWAY
 SOMERVILLE, MA
 VERIZON - PETITION PLAN

SURVEYED BY: PIKE TELECOM PRINT NO: 1 OF 1
 DRAWN BY: EP SCALE: AS NOTED
 DATE: 07/26/24 AS-BUILT:

27/26/2024 I:\CADD\PROJECTS\144TC4T\144TC4T.dwg 315 BROADWAY\AUTOCAD\DWG\MATCHET_VPT_2666016 - 315 BROADWAY - PPL.dwg

BROADWAY TEMPLE LLC
159 CAMBRIDGE ST
ALLSTON, MA 02134

HOWARD J W TRUSTEE
P O BOX 440361
SOMERVILLE, MA 02144 USA