

### 3.2.10 Apartment Building (continued)

c. Massing & Height

d. Uses & Features

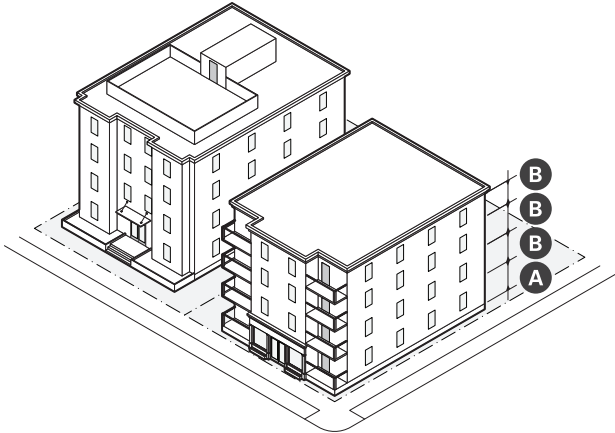
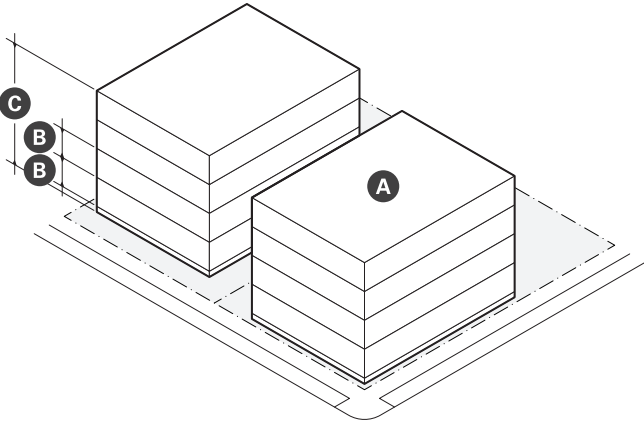

Main Mass	
FACADE Build Out (min)	80%
<u>Facade Build Out Abutting NR (min)</u>	<u>70%</u>
<b>A</b> FLOOR PLATE (max)	--
with FORECOURT	16,000 sf
without a FORECOURT	7,000 sf
GROUND STORY Elevation (min)	2 ft
<b>B</b> STORY Height (min/max)	10 ft 12 ft
<b>C</b> Number of Stories (min/max)	2 4
Roof Type	Flat, MANSARD

Facade Composition		
<b>A</b> GROUND STORY FENESTRATION (min/max)	15%	50%
<b>B</b> UPPER STORY FENESTRATION (min/max)	15%	50%

Use & Occupancy	
GROSS FLOOR AREA per DU (min)	--
LOT AREA < 5,000 sf	1,500
LOT AREA >= 5,000 sf	1,125
NET ZERO READY BUILDING	875
Outdoor AMENITY SPACE (min)	1/DU