

2. GLOSSARY & OVERVIEW

Glossary

	parcel to another is minor or substantial.
Lot Line, Front	Any lot line abutting a civic space or thoroughfare, excluding alleys.
Lot Line, Party	A side lot line shared between two attached or semi-detached Building Types.
Lot Line, Primary Front	Any front lot line abutting a pedestrian street.
Lot Line, Rear	Any lot line which is parallel to or within forty-five (45) degrees of being parallel to a front lot line, unless that lot line is a side lot line of an abutting lot.
Lot Line, Side	Any lot line other than a front or rear lot line.
Lot Merger	The consolidation of two (2) or more adjacent lots by eliminating the lot line that previously separated them.
Lot Split	The division of a lot into two (2) smaller lots.
Lot Width	The length of the front lot line of a lot.
Lumen	The unit of measure used to quantify the amount of light produced by a lamp or emitted from a luminaire (as distinct from watt, a measure of power consumption).
Luminaire	A light unit or fixture including any bulb(s), tube(s), housing, reflective shield, lens and/or ballast. The complete lighting unit (fixture), consisting of a lamp, or lamps and ballasts, when applicable, together with the parts designed to distribute the light (reflector, lens, diffuser), to position and protect the lamps, and to connect the lamps to the power supply.
Luminaire, Fully Shielded:	A luminaire constructed and installed in such a manner that all light emitted by the luminaire, either directly from the lamp or a diffusing element, or indirectly by reflection or refraction from any part of the luminaire, is projected below the horizontal plane through the luminaire's lowest light emitting part.
Maintenance or Repair Services	A Commercial Services principal use category. See §9.2.6.j Maintenance or Repair Services.
Major Utility Facility	A Civic & Institutional principal use category. See §9.2.5.e Major Utility Facility.
Manufacturing	An Industrial principal use category. See §9.2.8.c Manufacturing.
Market Rate Unit	A dwelling unit developed and sold or rented on the open market.
Main Massing	The primary massing of a Building Type, excluding building components.
Mezzanine	An intermediate floor level between the floor and ceiling of a story.
Minor Utility Facility	A Civic & Institutional principal use category. See §9.2.5.d Minor Utility Facility.
Mobility Management	A broad range of strategies intended to reduce automobile trips. The alteration of travel behavior through a program of incentives, services, and policies, including encouraging the use of alternatives to single-occupant vehicles such as public transit, cycling, walking, car-pooling/ van-pooling and changes in work schedule that move trips out of the peak period or eliminate them altogether.
Mobility Management Association	Organizations formed to help individual uses and property owners collectively implement and administer the Mobility Management programs and services.
Motor Vehicle Parking	An Auto-Oriented principal use category. See §9.2.3.d Motor Vehicle Parking.
Mounting Height	The height of the center of a luminaire above ground level.
Moving or Storage Services	An Industrial principal use category. See §9.2.8.d Moving or Storage Services.
Modification	Construction that alters, expands, reconstructs, extends, or structurally changes an existing structure or that changes the number of dwelling units within an existing structure.
Monopole	A free-standing (or wire-supported) tower for wireless telecommunications facilities.
Mulch, Groundcover	A protective above-ground dressing consisting of organic, non-recycled wood or bark used for moisture control, weed control, erosion control, temperature control, or other similar purposes.
Museum	A Civic & Institutional principal use category. See §9.2.5.f Museum.
Mystic River Bank	The portion of land surface abutting and confining the Mystic River, as defined by 310 CMR 10.54.2.C, as amended.

2. GLOSSARY & OVERVIEW

Standards & Measurements

2.4 STANDARDS & MEASUREMENTS

1. General

- a. This section provides an explanation of dimensional standards found in this Ordinance, defines how to measure each requirement, and provides other standards and reference information as necessary.

2. Lot Standards

- a. LOT LINES
 - i. Any LOT LINE ABUTTING a PEDESTRIAN STREET is a **primary** FRONT LOT LINE.
 - ii. The FRONT LOT LINE of any INTERIOR LOT OR KEY LOT is a **primary** FRONT LOT LINE.
 - iii. CORNER LOTS and THROUGH LOTS have two FRONT LOT LINES **and two side lot lines with no rear lot line.**
 - a). Any FRONT LOT LINE of a CORNER LOT ABUTTING a PEDESTRIAN STREET is a **primary** FRONT LOT LINE.
 - b). For all other CORNER LOTS, the **primary** FRONT LOT LINE is designated by the PROPERTY OWNER, with all remaining FRONT LOT LINES designated as secondary FRONT LOT LINES.
 - c). Both FRONT LOT LINES of a THROUGH LOT are **primary** FRONT LOT LINES.
- b. LOT Dimensions
 - i. General
 - a). Lots must have dimensions appropriate for one or more of the building type(s) or civic spaces permitted for the district where the lot is located.
 - ii. LOT WIDTH
 - a). LOT WIDTH is measured as the length of the FRONT LOT LINE of a LOT, except as follows:
 - i). For a FLAG LOT, only the 'pole' or 'post' portion of the LOT is USED to measure LOT WIDTH.

- iii. LOT DEPTH
 - a). LOT DEPTH is measured as the horizontal distance between the midpoint of the PRIMARY FRONT LOT LINE and the midpoint of the REAR LOT LINE or to the most distant point on any other LOT LINE where there is NO REAR LOT LINE.
- c. LOT DEVELOPMENT
 - i. LOT Coverage
 - a). The maximum area of a LOT that is permitted to be covered by the combination of principal buildings, accessory buildings, accessory structures and impermeable surfaces.
 - b). The lot coverage of a STRUCTURE is measured from the outside of the exterior walls at the GROUND story, including covered porches and other building components.
 - c). The lot coverage (and permeable area) of porous asphalt, pervious concrete, paving stones, or grass pavers is calculated using the runoff coefficient provided by the manufacturer.
 - ii. Green Score
 - a). Green Score is landscape requirement measured as a ratio of the weighted value of various landscape elements to total lot area. See §10.4 Green Score for more information.
 - iii. Open Space
 - a). The minimum area of a lot that must be provided as open space.

Figure 2.4.2 Lot Dimensions

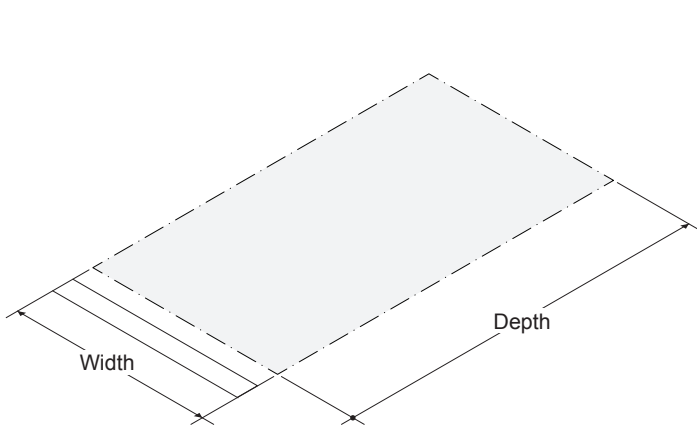
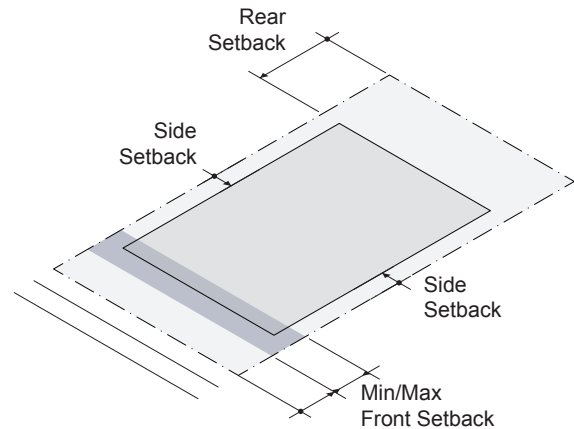

Figure 2.4.3 (a) Building Setbacks



2. GLOSSARY & OVERVIEW

Standards & Measurements

- may fully ENCROACH into a required front, side, or rear SETBACK.
- viii. Transformers and other cabinet STRUCTURES may fully ENCROACH into a required side or rear SETBACK.
- ix. Terraces, uncovered and unenclosed PATIOS, and underground STRUCTURES may fully ENCROACH into a required SETBACK.
- x. Trellises or other STRUCTURES attached to a BUILDING for the sole purpose of growing vines or other vegetation may ENCROACH into a required SETBACK provided that at least two (2) feet is maintained from the vertical plane of any SIDE LOT LINE.
- xi. ACCESSORY STRUCTURES, fences and walls, SIGNS, and landscape buffers may ENCROACH as indicated in Article 10: DEVELOPMENT Standards.
- e. FRONTAGE AREA
 - ~~i. The area of a lot between the facade of a principal building and any front lot line(s) extending fully to each side lot line(s) is the frontage area of a lot.~~
 - i. Motor vehicle parking, excluding parking in the drive aisle of a driveway, and parking spaces are not permitted in the frontage area and driveways are not permitted in the FRONTAGE AREA between a BUILDING and the FRONT LOT LINE.
 - ii. CORNER LOTS and THROUGH LOTS have two FRONTAGE AREAS.
 - a). Any FRONTAGE AREA of a CORNER LOT ABUTTING a PEDESTRIAN STREET is a primary FRONTAGE AREA.
 - b). For all other CORNER LOTS, the primary FRONTAGE AREA corresponds with the primary FRONT LOT LINE designated by the PROPERTY OWNER, with all remaining FRONTAGE AREA designated as secondary FRONTAGE AREA.

- c). Both FRONTAGE AREAS of a THROUGH LOT are primary FRONTAGE AREA.

4. Massing & Height

- a. MAIN MASSING
 - i. FACADE Build Out
 - a). Building façade(s) must be built parallel to the FRONT LOT LINE for the minimum facade build out specified for each BUILDING TYPE and is measured as a percentage of the LOT width, measured at the maximum front SETBACK line.
 - b). For LOTS with frontage on three (3) sides, the FACADE build out along a secondary frontage is only applicable to the minimum number of stories required for each BUILDING TYPE.
 - c). FORECOURTS are considered part of the BUILDING for the purpose of measuring FACADE build out.
 - ii. BUILDING WIDTH
 - a). Width is measured parallel to the FACADE of a BUILDING, from the exterior of each side wall.
 - iii. BUILDING Depth
 - a). Depth is measured perpendicularly from the FACADE as the maximum length of any exterior side wall of a BUILDING.
 - iv. FLOOR PLATE
 - a). FLOOR PLATE is measured as the total GROSS FLOOR AREA of a single STORY of a BUILDING, excluding BUILDING COMPONENTS.
 - v. GROUND STORY Elevation
 - a). GROUND STORY elevation is measured as the vertical distance from the average finished ground level at the FACADE(s) to the top of the finished floor of the GROUND STORY.

Figure 2.4.2 (c) Frontage Area

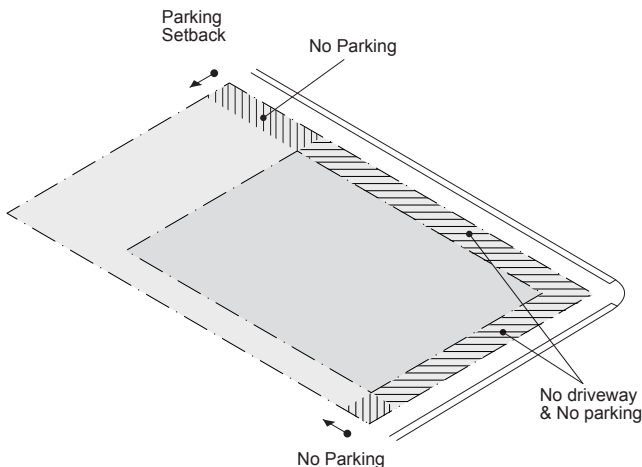
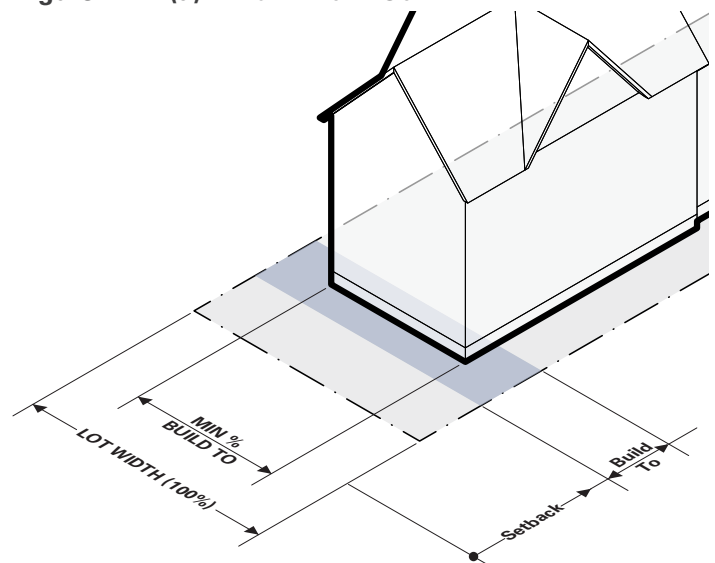

Figure 2.4.4 (a) FACADE BUILD-OUT



4. MID-RISE DISTRICTS

Mid-Rise 3 (MR3)

4.1.7. Apartment Building (continued)

a. LOT Standards

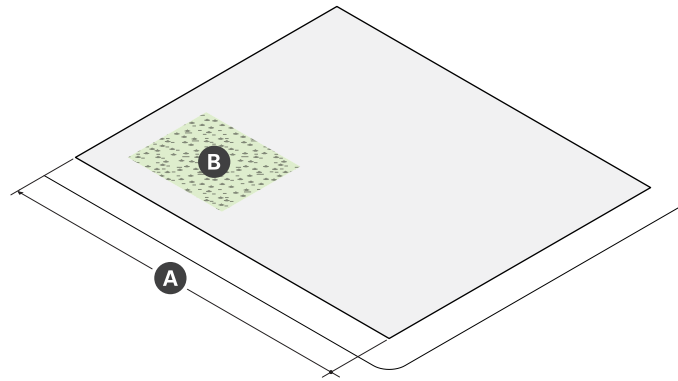

Lot Dimensions	
A LOT WIDTH (min)	30 ft

Lot Development	
LOT Coverage (max)	90%
GREEN SCORE	--
Minimum	0.25
Ideal	0.30
B OPEN SPACE (min)	15%

b. BUILDING Placement

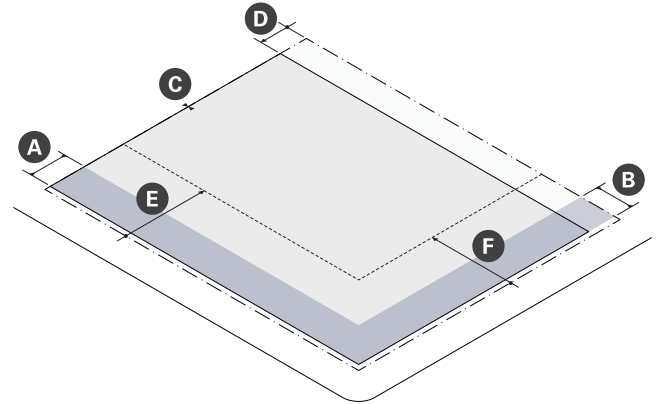

Building Setbacks		
	<u>Curb Setback (min)</u>	<u>12 ft</u>
A	Primary Front SETBACK (min/max)	2 ft 12 ft
B	Secondary Front SETBACK (min/max)	2 ft 12 ft
C	Side SETBACK (min)	0 ft
	Side SETBACK ABUTTING NR or LHD (min)	10 ft
D	Rear SETBACK (min)	--
	ALLEY OR R-ROW	0 ft
	No ALLEY	10 ft
	No ALLEY & ABUTTING NR or LHD	20 ft

Parking Setbacks		
E	Primary Front SETBACK (min)	--
	SURFACE PARKING	30 ft
	STRUCTURED PARKING	30 ft
F	Secondary Front SETBACK (min)	--
	SURFACE PARKING	10 ft
	STRUCTURED PARKING	2 ft

4. MID-RISE DISTRICTS

Mid-Rise 3 (MR3)

4.1.8. General Building (continued)

a. LOT Standards

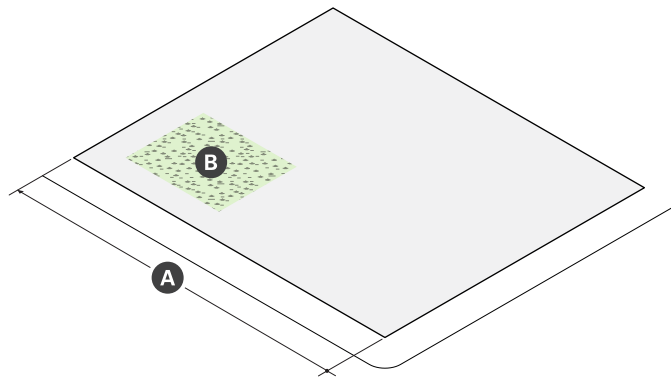

Lot Dimensions	
A LOT WIDTH (min)	30 ft

Lot Development	
LOT Coverage (max)	90%
GREEN SCORE	--
Minimum	0.25
Ideal	0.30
B OPEN SPACE (min)	15%

b. BUILDING Placement

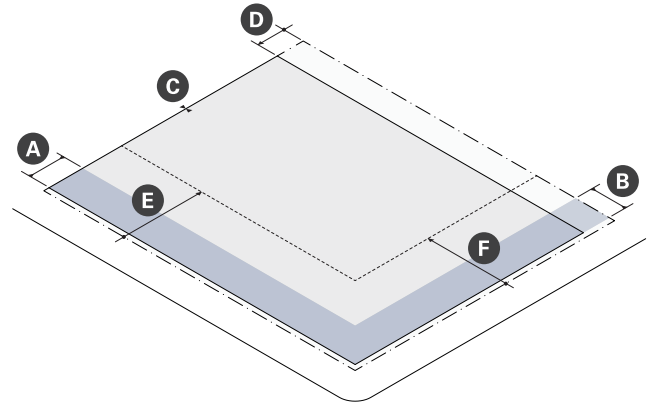

Building Setbacks	
Curb Setback (min)	12 ft
A Primary Front SETBACK (min/max)	2 ft 12 ft
B Secondary Front SETBACK (min/max)	2 ft 12 ft
C Side SETBACK (min)	0 ft
Side SETBACK ABUTTING NR or LHD (min)	10 ft
D Rear SETBACK (min)	--
ALLEY OR R-ROW	0 ft
No ALLEY	10 ft
No ALLEY & ABUTTING NR or LHD	20 ft

Parking Setbacks	
E Primary Front SETBACK (min)	--
SURFACE PARKING	30 ft
STRUCTURED PARKING	30 ft
F Secondary Front SETBACK (min)	--
SURFACE PARKING	10 ft
STRUCTURED PARKING	2 ft

4. MID-RISE DISTRICTS

Mid-Rise 3 (MR3)

4.1.9 Commercial Building (continued)

a. LOT Standards

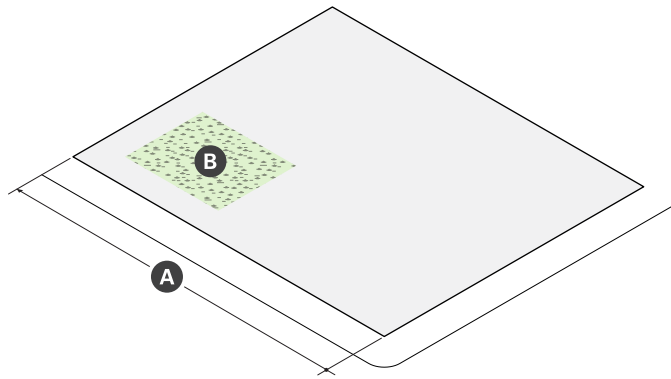

Lot Dimensions	
A LOT WIDTH (min)	30 ft

Lot Development	
LOT Coverage (max)	90%
GREEN SCORE	--
Minimum	0.25
Ideal	0.30
B OPEN SPACE (min)	15%

b. BUILDING Placement

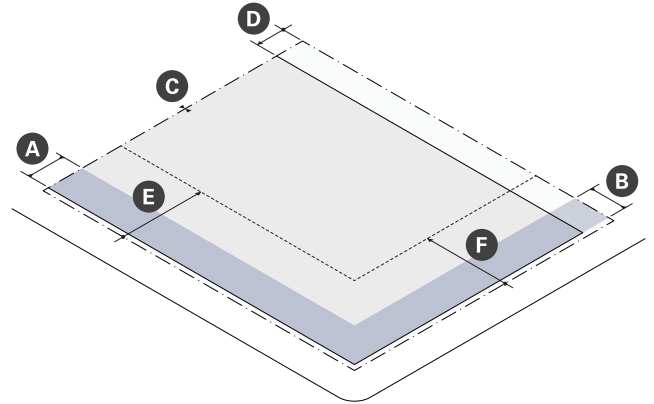

Building Setbacks	
<u>Curb Setback (min)</u>	<u>12 ft</u>
A Primary Front SETBACK (min/max)	2 ft 12 ft
B Secondary Front SETBACK (min/max)	2 ft 12 ft
C Side SETBACK (min)	0 ft
Side SETBACK ABUTTING NR or LHD (min)	10 ft
D Rear SETBACK (min)	--
ALLEY OR R-ROW	0 ft
No ALLEY	10 ft
No ALLEY & ABUTTING NR or LHD	20 ft

Parking Setbacks	
E Primary Front SETBACK (min)	--
SURFACE PARKING	30 ft
STRUCTURED PARKING	30 ft
F Secondary Front SETBACK (min)	--
SURFACE PARKING	10 ft
STRUCTURED PARKING	2 ft

4. MID-RISE DISTRICTS

Mid-Rise 3 (MR3)

16. Public Realm

a. Sidewalks

~~i. When development occurs on any lot abutting a sidewalk that is less than twelve (12) feet in total width, the building must be set back an additional distance to accommodate expansion of the abutting sidewalk must be provided to a width of at least twelve (12) feet. The minimum and maximum front setbacks for each building type are increased accordingly.~~

i. For any lot abutting a sidewalk that is less than twelve (12) feet in width, the frontage area must be paved to provide a sidewalk that is at least twelve (12) feet in total width.

b. Sidewalk CURB CUTS

i. A CURB CUT requires a permit from the City Engineer and must be compliant with all City Ordinances.

ii. Unless otherwise specified, the City Engineer may not permit more than one (1) CURB CUT per FRONT LOT LINE of a LOT.

iii. CURB CUTS are prohibited along all THOROUGHFARES designated as a PEDESTRIAN STREET.

iv. CURB CUTS must be located to minimize conflicts with pedestrians and bicyclists and must have a clear distance from fire hydrants, STREET TREES, utility poles, and other furnishings as deemed necessary by the City Engineer.

a). CURB CUTS for commercial or high-volume driveways should be at least one-hundred (100) feet from an UNSIGNALIZED or SIGNALIZED intersection.

b). CURB CUTS for residential driveways should be at least twenty (20) feet from an UNSIGNALIZED intersection and at least forty (40) feet from a SIGNALIZED intersection.

v. The interior width of a CURB CUT (between curb stones) may be no wider than the driveway, vehicular entrance, or loading facility it serves.

vi. A DRIVEWAY APRON may be installed only within the furnishing zone of a sidewalk and must be constructed in accordance with all standards established by relevant City Departments.

vii. The grade, cross slope, and clear width of the walkway of a sidewalk must be maintained between the DRIVEWAY APRON and the ABUTTING driveway. The appearance of the walkway (ie. scoring pattern or paving material) must indicate that, although a vehicle may cross, the area traversed by a vehicle remains part of the sidewalk.

Figure 4.1.17 Sidewalk Curb Cuts

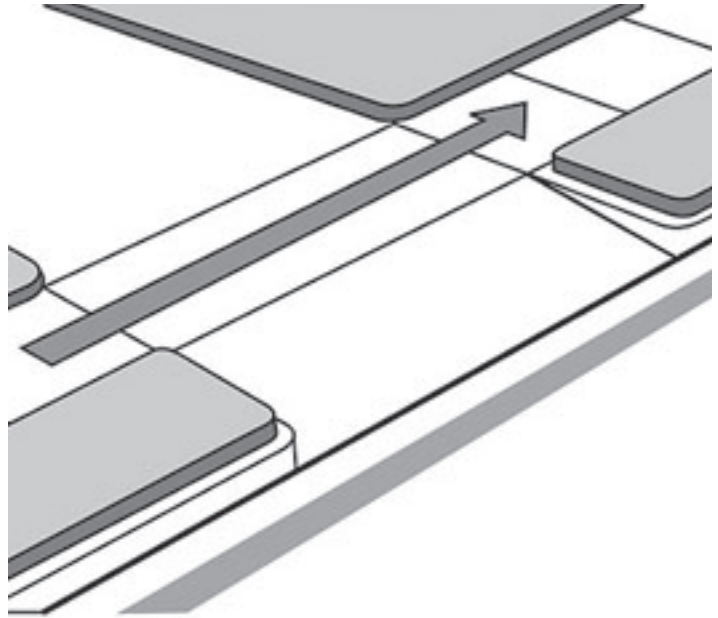

4. MID-RISE DISTRICTS

Mid-Rise 4 (MR4)

4.2.7. Apartment Building (continued)

a. Lot Standards

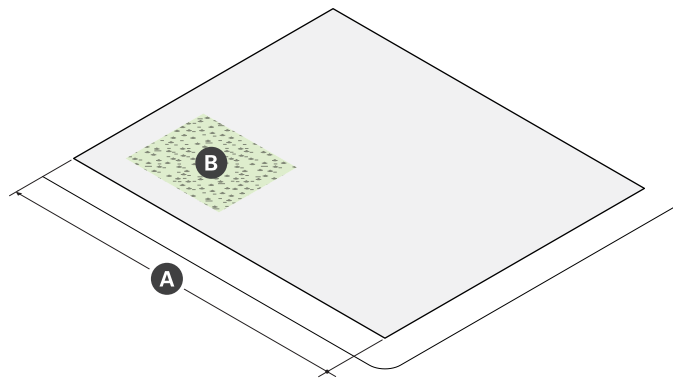

Lot Dimensions	
A LOT WIDTH (min)	30 ft

Lot Development	
LOT Coverage (max)	90%
GREEN SCORE	--
Minimum	0.25
Ideal	0.30
B OPEN SPACE (min)	15%

b. BUILDING Placement

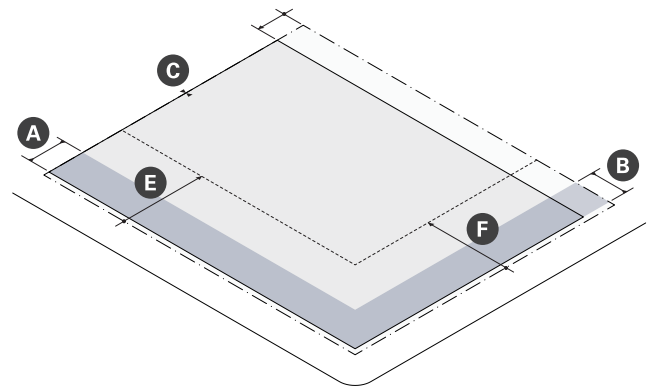

Building Setbacks	
Curb Setback (min)	12 ft
A Primary Front SETBACK (min/max)	2 ft 12 ft
B Secondary Front SETBACK (min/max)	2 ft 12 ft
C Side SETBACK (min)	--
Abutting an Alley or R-ROW	0 ft
Abutting any non-NR or -LHD	0 ft
1st - 3rd Story abutting NR or LHD	10 ft
4th Story abutting NR or LHD	30 ft
D Rear Setback (min)	--
Abutting an Alley or R-ROW	0 ft
Abutting any non-NR or -LHD	10 ft
1st - 3rd Story abutting NR or LHD	20 ft
4th Story abutting NR or LHD	30 ft

Parking Setbacks	
E Primary Front SETBACK (min)	--
SURFACE PARKING	30 ft
STRUCTURED PARKING	30 ft
F Secondary Front SETBACK (min)	--
SURFACE PARKING	10 ft
STRUCTURED PARKING	2 ft

4. MID-RISE DISTRICTS

Mid-Rise 4 (MR4)

4.2.8. General Building (continued)

a. LOT Standards

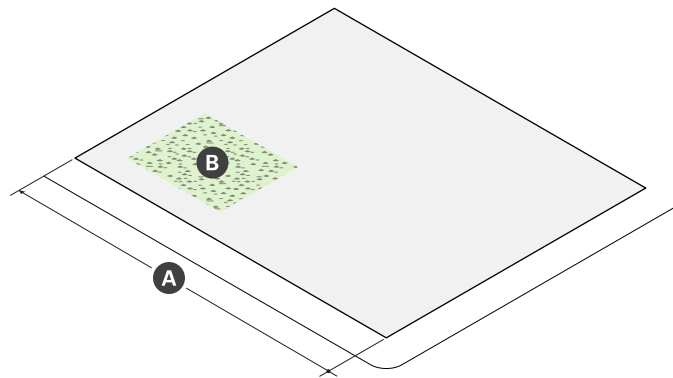

Lot Dimensions	
A LOT WIDTH (min)	30 ft

Lot Development	
LOT Coverage (max)	90%
GREEN SCORE	--
Minimum	0.25
Ideal	0.30
B OPEN SPACE (min)	15%

b. BUILDING Placement

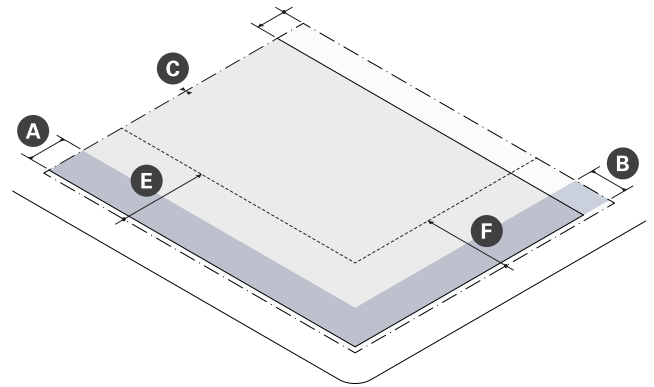

Building Setbacks	
Curb Setback (min)	12 ft
A Primary Front SETBACK (min/max)	2 ft 15 ft
B Secondary Front SETBACK (min/max)	2 ft 15 ft
C Side SETBACK (min)	--
Abutting an Alley or R-ROW	0 ft
Abutting any non-NR or -LHD	0 ft
1st - 3rd Story abutting NR or LHD	10 ft
4th Story abutting NR or LHD	30 ft
D Rear Setback (min)	--
Abutting an Alley or R-ROW	0 ft
Abutting any non-NR or -LHD	10 ft
1st - 3rd Story abutting NR or LHD	20 ft
4th Story abutting NR or LHD	30 ft

Parking Setbacks	
E Primary Front SETBACK (min)	--
SURFACE PARKING	30 ft
STRUCTURED PARKING	30 ft
F Secondary Front SETBACK (min)	--
SURFACE PARKING	10 ft
STRUCTURED PARKING	2 ft

4. MID-RISE DISTRICTS

Mid-Rise 4 (MR4)

4.2.9. Commercial Building (continued)

a. LOT Standards

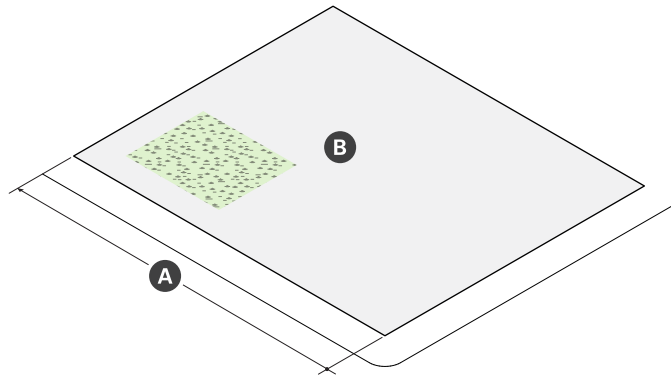

Lot Dimensions	
A LOT WIDTH (min)	30 ft

Lot Development	
LOT Coverage (max)	90%
GREEN SCORE	--
Minimum	0.25
Ideal	0.30
B OPEN SPACE (min)	15%

b. BUILDING Placement

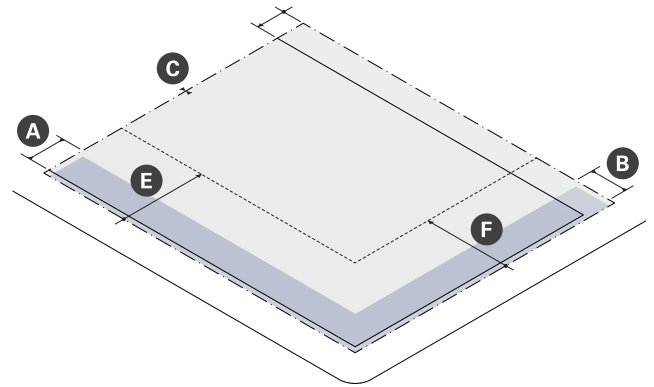

Building Setbacks	
Curb Setback (min)	12 ft
A Primary Front SETBACK (min/max)	2 ft 15 ft
B Secondary Front SETBACK (min/max)	2 ft 15 ft
C Side SETBACK (min)	--
Abutting an Alley or R-ROW	0 ft
Abutting any non-NR or -LHD	0 ft
1st - 3rd Story abutting NR or LHD	10 ft
4th Story abutting NR or LHD	30 ft
D Rear Setback (min)	--
Abutting an Alley or R-ROW	0 ft
Abutting any non-NR or -LHD	10 ft
1st - 3rd Story abutting NR or LHD	20 ft
4th Story abutting NR or LHD	30 ft

Parking Setbacks	
E Primary Front SETBACK (min)	--
SURFACE PARKING	30 ft
STRUCTURED PARKING	30 ft
F Secondary Front SETBACK (min)	--
SURFACE PARKING	10 ft
STRUCTURED PARKING	2 ft

4. MID-RISE DISTRICTS

Mid-Rise 4 (MR4)

16. Public Realm

a. Sidewalks

~~i. When development occurs on any lot abutting a sidewalk that is less than twelve (12) feet in total width, the building must be set back an additional distance to accommodate expansion of the abutting sidewalk must be provided to a width of at least twelve (12) feet. The minimum and maximum front setbacks for each building type are increased accordingly.~~

i. For any lot abutting a sidewalk that is less than twelve (12) feet in width, the frontage area must be paved to provide a sidewalk that is at least twelve (12) feet in total width.

b. Sidewalk CURB CUTS

i. A CURB CUT requires a permit from the City Engineer and must be compliant with all City Ordinances.

ii. Unless otherwise specified, the City Engineer may not permit more than one (1) CURB CUT per FRONT LOT LINE of a LOT.

iii. CURB CUTS are prohibited along all THOROUGHFARES designated as a PEDESTRIAN STREET.

iv. CURB CUTS must be located to minimize conflicts with pedestrians and bicyclists and must have a clear distance from fire hydrants, STREET TREES, utility poles, and other furnishings as deemed necessary by the City Engineer.

a). CURB CUTS for commercial or high-volume driveways should be at least one-hundred (100) feet from an UNSIGNALIZED or SIGNALIZED intersection.

b). CURB CUTS for residential driveways should be at least twenty (20) feet from an UNSIGNALIZED intersection and at least forty (40) feet from a SIGNALIZED intersection.

v. The interior width of a CURB CUT (between curb stones) may be no wider than the driveway, vehicular entrance, or loading facility it serves.

vi. A DRIVEWAY APRON may be installed only within the furnishing zone of a sidewalk and must be constructed in accordance with all standards established by relevant City Departments.

vii. The grade, cross slope, and clear width of the walkway of a sidewalk must be maintained between the DRIVEWAY APRON and the ABUTTING driveway. The appearance of the walkway (ie. scoring pattern or paving material) must indicate that, although a vehicle may cross, the area traversed by a vehicle remains part of the sidewalk.

Figure 4.2.16 Sidewalk Curb Cuts

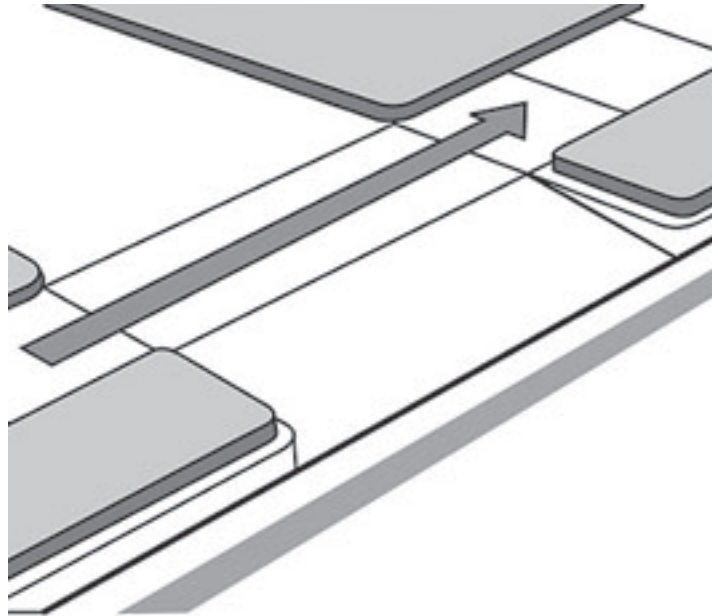

4. MID-RISE DISTRICTS

Mid-Rise 5 (MR5)

4.3.7. Apartment Building (continued)

a. Lot Standards

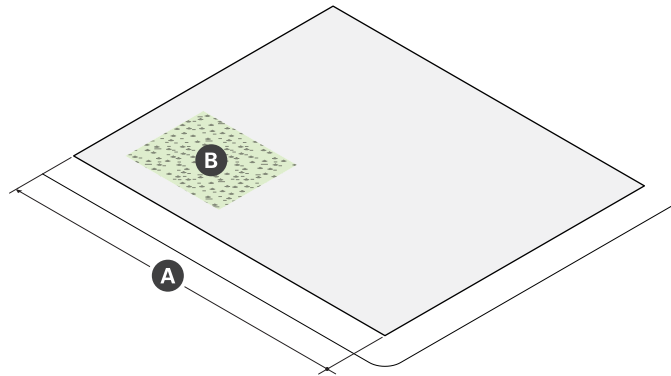

Lot Dimensions	
A LOT WIDTH (min)	30 ft

Lot Development	
LOT Coverage (max)	90%
GREEN SCORE	--
Minimum	0.20
Ideal	0.25
B OPEN SPACE (min)	15%

b. BUILDING Placement

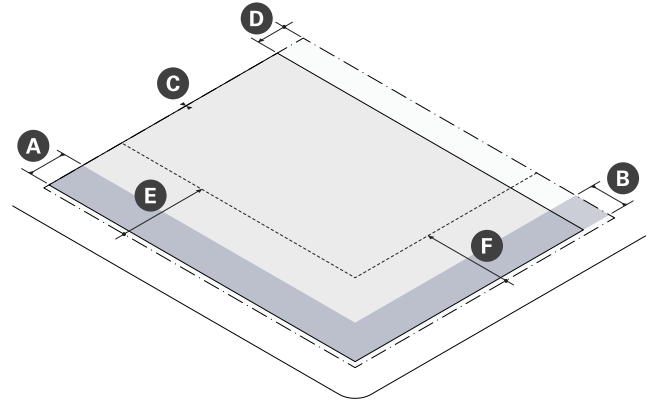

Building Setbacks	
Curb Setback (min)	12 ft
A Primary Front SETBACK (min/max)	2 ft 12 ft
B Secondary Front SETBACK (min/max)	2 ft 12 ft
C Side SETBACK (min)	--
Abutting an Alley or R-ROW	0 ft
Abutting any non-NR or -LHD	0 ft
1st - 3rd Story abutting NR or LHD	10 ft
4th - 5th Story abutting NR or LHD	30 ft
D Rear Setback (min)	--
Abutting an Alley or R-ROW	0 ft
Abutting any non-NR or -LHD	10 ft
1st - 3rd Story abutting NR or LHD	20 ft
4th - 5th Story abutting NR or LHD	30 ft

Parking Setbacks	
E Primary Front Setback (min)	30 ft
F Secondary Front Setback (min)	30 ft

4. MID-RISE DISTRICTS

Mid-Rise 5 (MR5)

4.3.8. General Building (continued)

a. LOT Standards

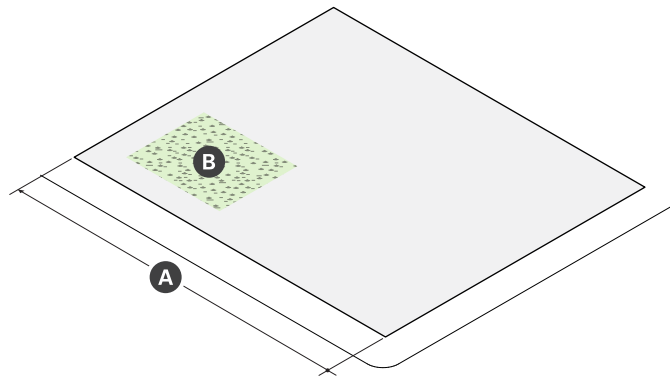

Lot Dimensions	
A LOT WIDTH (min)	30 ft

Lot Development	
LOT Coverage (max)	90%
GREEN SCORE	--
Minimum	0.20
Ideal	0.25
B OPEN SPACE (min)	15%

b. BUILDING Placement

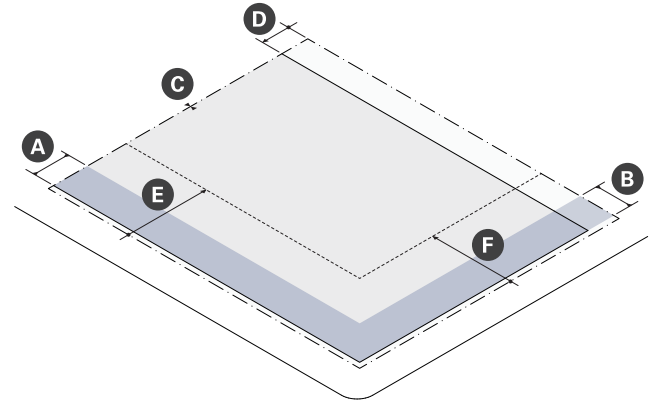

Building Setbacks	
<u>Curb Setback (min)</u>	<u>12 ft</u>
A Primary Front SETBACK (min/max)	2 ft 15 ft
B Secondary Front SETBACK (min/max)	2 ft 15 ft
C Side SETBACK (min)	--
Abutting an Alley or R-ROW	0 ft
Abutting any non-NR or -LHD	0 ft
1st - 3rd Story abutting NR or LHD	10 ft
4th - 5th Story abutting NR or LHD	30 ft
D Rear Setback (min)	--
Abutting an Alley or R-ROW	0 ft
Abutting any non-NR or -LHD	10 ft
1st - 3rd Story abutting NR or LHD	20 ft
4th - 5th Story abutting NR or LHD	30 ft

Parking Setbacks	
E Primary Front Setback (min)	30 ft
F Secondary Front Setback (min)	30 ft

4. MID-RISE DISTRICTS

Mid-Rise 5 (MR5)

4.3.9. Commercial Building (continued)

a. LOT Standards

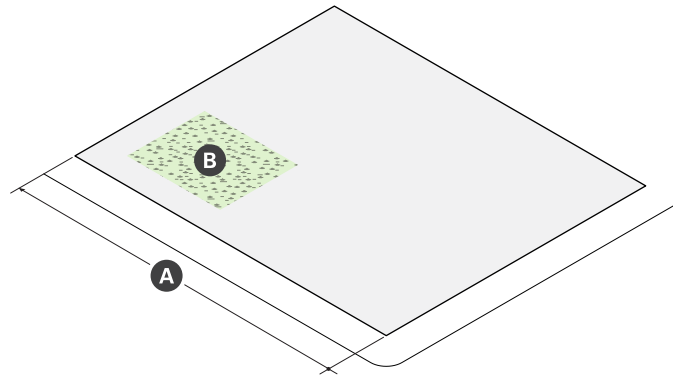

Lot Dimensions	
A LOT WIDTH (min)	30 ft

Lot Development	
LOT Coverage (max)	90%
GREEN SCORE	--
Minimum	0.20
Ideal	0.25
B OPEN SPACE (min)	15%

b. BUILDING Placement

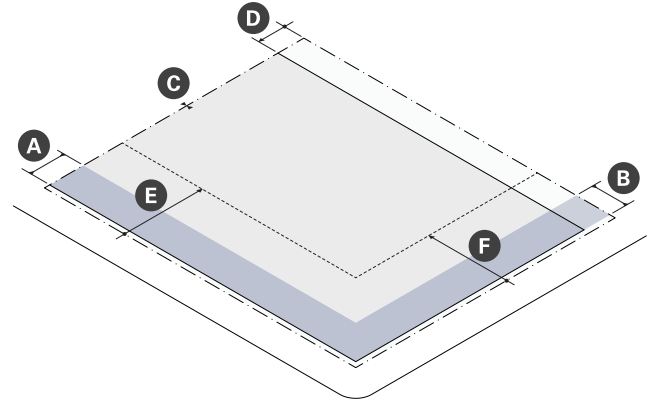

Building Setbacks	
Curb Setback (min)	12 ft
A Primary Front SETBACK (min/max)	2 ft 15 ft
B Secondary Front SETBACK (min/max)	2 ft 15 ft
C Side SETBACK (min)	--
Abutting an Alley or R-ROW	0 ft
Abutting any non-NR or -LHD	0 ft
1st - 3rd Story abutting NR or LHD	10 ft
4th - 5th Story abutting NR or LHD	30 ft
D Rear Setback (min)	--
Abutting an Alley or R-ROW	0 ft
Abutting any non-NR or -LHD	10 ft
1st - 3rd Story abutting NR or LHD	20 ft
4th - 5th Story abutting NR or LHD	30 ft

Parking Setbacks	
E Primary Front Setback (min)	30 ft
F Secondary Front Setback (min)	30 ft

4. MID-RISE DISTRICTS

Mid-Rise 5 (MR5)

16. Public Realm

a. Sidewalks

- ~~i. When development occurs on any lot abutting a sidewalk that is less than twelve (12) feet in total width, the building must be set back an additional distance to accommodate expansion of the abutting sidewalk must be provided to a width of at least twelve (12) feet. The minimum and maximum front setbacks for each building type are increased accordingly.~~
- i. For any lot abutting a sidewalk that is less than twelve (12) feet in width, the frontage area must be paved to provide a sidewalk that is at least twelve (12) feet in total width.

b. Sidewalk CURB CUTS

- i. A CURB CUT requires a permit from the City Engineer and must be compliant with all City Ordinances.
- ii. Unless otherwise specified, the City Engineer may not permit more than one (1) CURB CUT per FRONT LOT LINE of a LOT.
- iii. CURB CUTS are prohibited along all THOROUGHFARES designated as a PEDESTRIAN STREET.
- iv. CURB CUTS must be located to minimize conflicts with pedestrians and bicyclists and must have a clear distance from fire hydrants, STREET TREES, utility poles, and other furnishings as deemed necessary by the City Engineer.
 - a). CURB CUTS for commercial or high-volume driveways should be at least one-hundred (100) feet from an UNSIGNALIZED or SIGNALIZED intersection.
 - b). CURB CUTS for residential driveways should be at least twenty (20) feet from an UNSIGNALIZED intersection and at least forty (40) feet from a SIGNALIZED intersection.
- v. The interior width of a CURB CUT (between curb stones) may be no wider than the driveway, vehicular entrance, or loading facility it serves.
- vi. A DRIVEWAY APRON may be installed only within the furnishing zone of a sidewalk and must be constructed in accordance with all standards established by relevant City Departments.
- vii. The grade, cross slope, and clear width of the walkway of a sidewalk must be maintained between the DRIVEWAY APRON and the ABUTTING driveway. The appearance of the walkway (ie. scoring pattern or paving material) must indicate that, although a vehicle may cross, the area traversed by a vehicle remains part of the sidewalk.

Figure 4.3.16 Sidewalk Curb Cuts

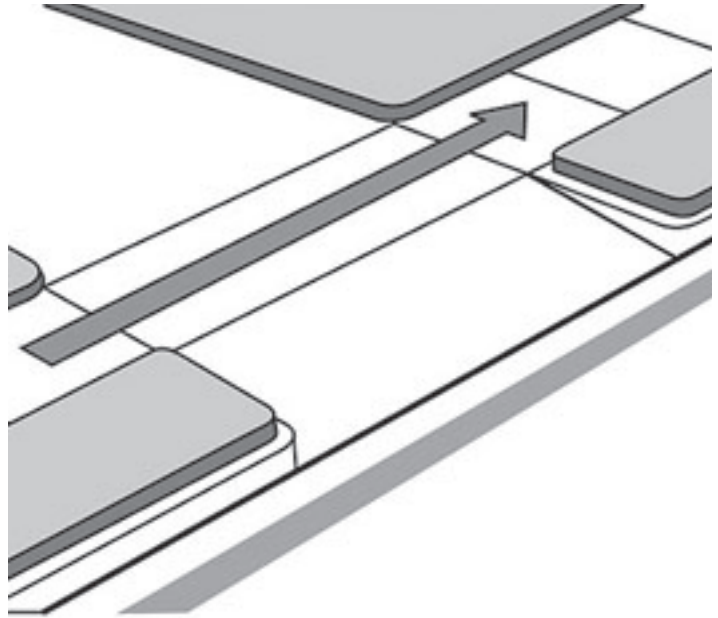

4. MID-RISE DISTRICTS

Mid-Rise 6 (MR6)

4.4.7. Apartment Building (continued)

a. LOT Standards

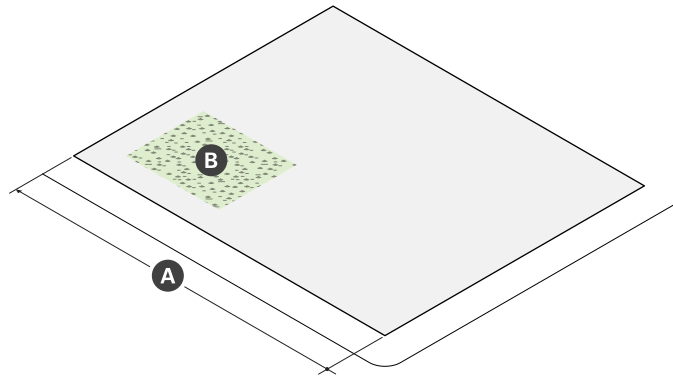

Lot Dimensions	
A LOT WIDTH (min)	30 ft

Lot Development	
LOT Coverage (max)	100%
GREEN SCORE	--
Minimum	0.20
Ideal	0.25
B OPEN SPACE (min)	15%

b. BUILDING Placement

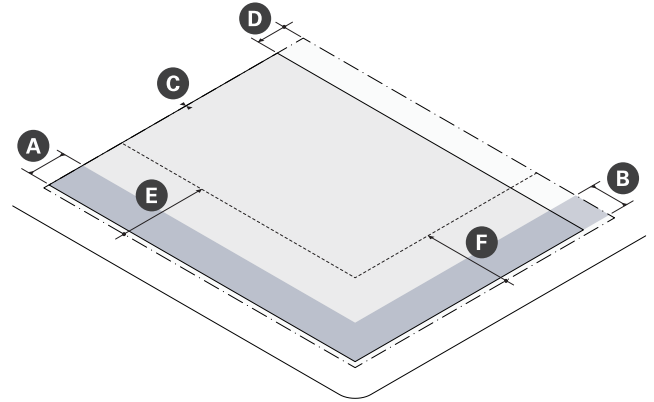

Building Setbacks	
Curb Setback (min)	12 ft
A Primary Front SETBACK (min/max)	2 ft 12 ft
B Secondary Front SETBACK (min/max)	2 ft 12 ft
C Side SETBACK (min)	--
Abutting an Alley or R-ROW	0 ft
Abutting any non-NR or -LHD	0 ft
1st - 3rd Story abutting NR or LHD	10 ft
4th - 6th Story abutting NR or LHD	30 ft
D Rear Setback (min)	--
Abutting an Alley or R-ROW	0 ft
Abutting any non-NR or -LHD	10 ft
1st - 3rd Story abutting NR or LHD	20 ft
4th - 6th Story abutting NR or LHD	30 ft

Parking Setbacks	
E Primary Front Setback (min)	30 ft
F Secondary Front Setback (min)	30 ft

4. MID-RISE DISTRICTS

Mid-Rise 6 (MR6)

4.4.8. General Building (continued)

a. LOT Standards

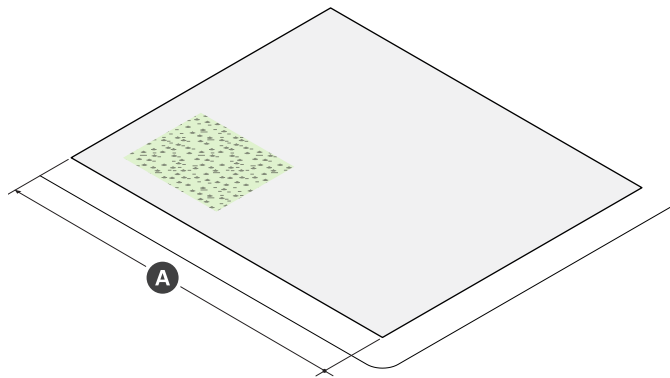

Lot Dimensions	
A LOT WIDTH (min)	30 ft

Lot Development	
LOT Coverage (max)	100%
GREEN SCORE	--
Minimum	0.20
Ideal	0.25
B OPEN SPACE (min)	15%

b. BUILDING Placement

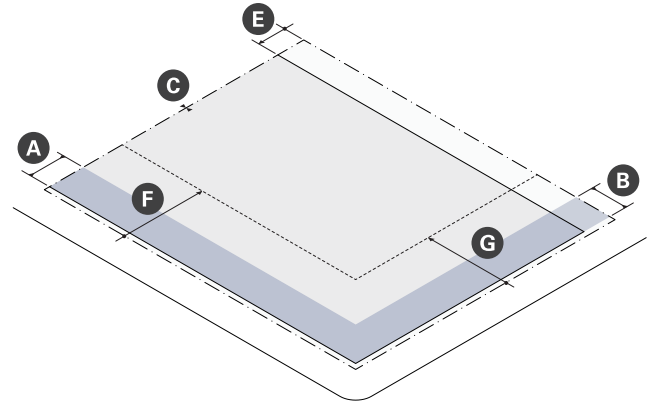

Building Setbacks	
<u>Curb Setback (min)</u>	<u>12 ft</u>
A Primary Front SETBACK (min/max)	2 ft 15 ft
B Secondary Front SETBACK (min/max)	2 ft 15 ft
C Side SETBACK (min)	--
Abutting an Alley or R-ROW	0 ft
Abutting any non-NR or -LHD	0 ft
1st - 3rd Story abutting NR or LHD	10 ft
4th - 6th Story abutting NR or LHD	30 ft
D Rear Setback (min)	--
Abutting an Alley or R-ROW	0 ft
Abutting any non-NR or -LHD	10 ft
1st - 3rd Story abutting NR or LHD	20 ft
4th - 6th Story abutting NR or LHD	30 ft

Parking Setbacks	
E Primary Front Setback (min)	30 ft
F Secondary Front Setback (min)	30 ft

4. MID-RISE DISTRICTS

Mid-Rise 6 (MR6)

4.4.9. Commercial Building (continued)

a. LOT Standards

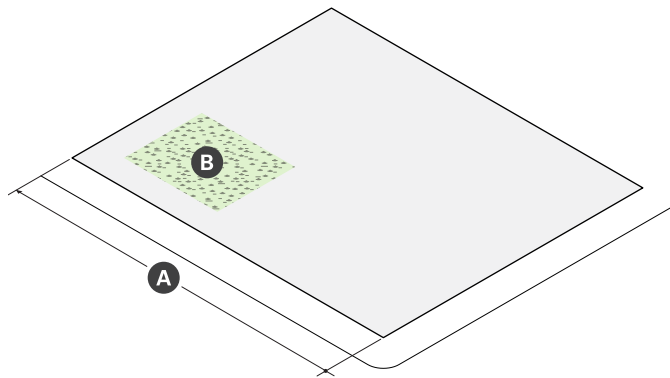

Lot Dimensions	
A LOT WIDTH (min)	30 ft

Lot Development	
LOT Coverage (max)	100%
GREEN SCORE	--
Minimum	0.20
Ideal	0.25
B OPEN SPACE (min)	15%

b. BUILDING Placement

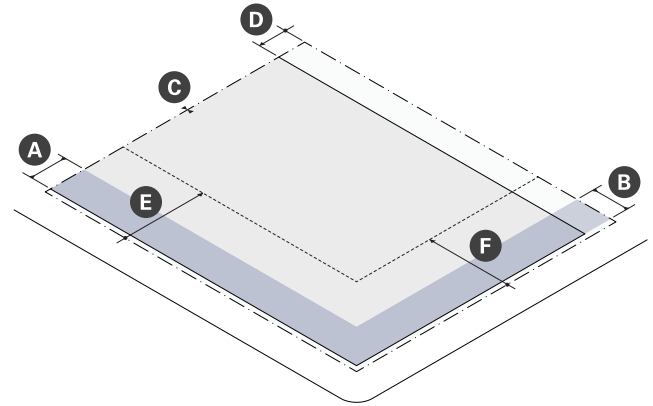

Building Setbacks	
<u>Curb Setback (min)</u>	<u>12 ft</u>
A Primary Front SETBACK (min/max)	2 ft 15 ft
B Secondary Front SETBACK (min/max)	2 ft 15 ft
C Side SETBACK (min)	--
Abutting an Alley or R-ROW	0 ft
Abutting any non-NR or -LHD	0 ft
1st - 3rd Story abutting NR or LHD	10 ft
4th - 6th Story abutting NR or LHD	30 ft
D Rear Setback (min)	--
Abutting an Alley or R-ROW	0 ft
Abutting any non-NR or -LHD	10 ft
1st - 3rd Story abutting NR or LHD	20 ft
4th - 6th Story abutting NR or LHD	30 ft

Parking Setbacks	
E Primary Front Setback (min)	30 ft
F Secondary Front Setback (min)	30 ft

4. MID-RISE DISTRICTS

Mid-Rise 6 (MR6)

4.4.10 Lab Building (continued)

a. LOT Standards

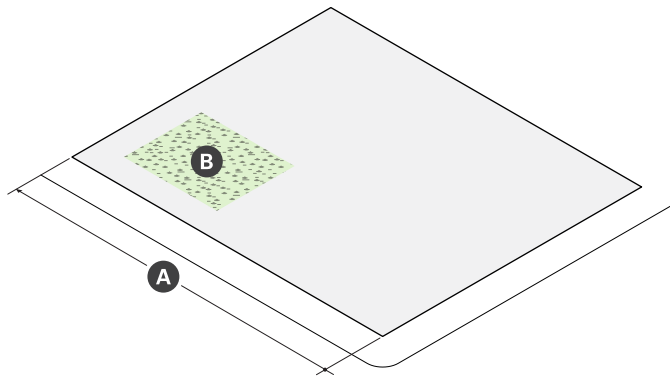

Lot Dimensions	
A LOT WIDTH (min)	30 ft

Lot Development	
LOT Coverage (max)	100%
GREEN SCORE	--
Minimum	0.20
Ideal	0.25
B OPEN SPACE (min)	15%

b. BUILDING Placement

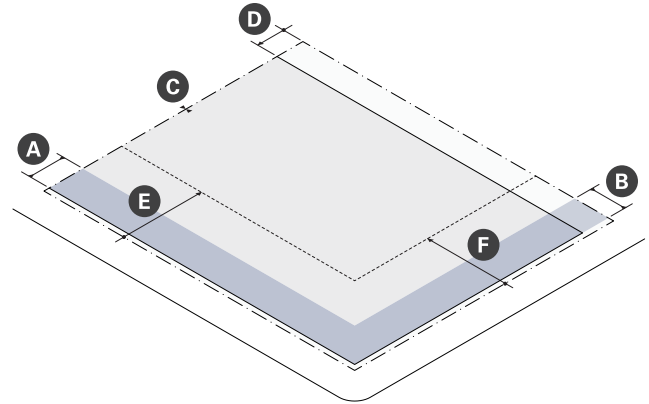

Building Setbacks	
<u>Curb Setback (min)</u>	<u>12 ft</u>
A Primary Front SETBACK (min/max)	2 ft 15 ft
B Secondary Front SETBACK (min/max)	2 ft 15 ft
C Side SETBACK (min)	--
Abutting an Alley or R-ROW	0 ft
Abutting any non-NR or -LHD	0 ft
1st - 3rd Story abutting NR or LHD	10 ft
4th - 6th Story abutting NR or LHD	30 ft
D Rear Setback (min)	--
Abutting an Alley or R-ROW	0 ft
Abutting any non-NR or -LHD	10 ft
1st - 3rd Story abutting NR or LHD	20 ft
4th - 6th Story abutting NR or LHD	30 ft

Parking Setbacks	
E Primary Front Setback (min)	30 ft
F Secondary Front Setback (min)	30 ft

4. MID-RISE DISTRICTS

Mid-Rise 6 (MR6)

Table 4.4.14 Permitted Uses (continued)

Use Category Specific Use	MR6
Accessory Uses	
Home Occupations (as noted below)	--
Creative Studio	N
Hobby Kennel	N
Home-Based Business	N
Home Day Care	N
Home Office	P
Urban Agriculture (as noted below)	--
Apiculture	P
Aviculture	P
Commercial Farming	P
Residential Gardening	P

P - Permitted SP - Special Permit Required N - Not Permitted
 (P or SP) - Permitted as specified per §4.4.14.b

15. Development Standards

- a. General
 - i. DEVELOPMENT is subject to the provisions of Article 10: DEVELOPMENT STANDARDS of this Ordinance. Where the provisions of this section conflict with those of Article 10, the provisions of Article 10 apply.
- b. SIGNS
 - i. A SIGN, individual numerals or letters, or a nonelectrical nameplate identifying the property address is required for all real property as follows:
 - a). Each GROUND STORY non-residential USE must identify the STREET address either on the PRINCIPAL ENTRANCE door or above or beside the PRINCIPAL ENTRANCE of the USE.
 - b). All residential BUILDING TYPES must identify the STREET address either on the PRINCIPAL ENTRANCE door, above or beside the PRINCIPAL ENTRANCE, or on a mailbox.
 - ii. Address SIGNS must be made easily visible through the USE of colors or materials that contrast with the background material they are attached to and must be conspicuously located to provide visibility from the THOROUGHFARE that the BUILDING faces.
 - iii. Address SIGNS must be twelve (12) inches in height or less and may include the name of the occupant.
- c. Roof-Mounted Mechanicals
 - i. Roof mounted mechanical equipment must be screened or enclosed within a rooftop penthouse.
 - a). Roof-mounted photovoltaic (PV) devices are exempt.
 - ii. Mechanical equipment, screening, and rooftop mechanical penthouses may exceed the maximum height permitted for each building type by Special Permit.
 - a). In addition to the review criteria for all Special Permits specified in §15.2.1.e. Review Criteria, the review board shall make findings considering the following in its discretion to approve or deny a special permit authorizing mechanical equipment, screening, or rooftop mechanical penthouse to exceed the maximum height permitted for each building type:
 - i). Reserved

5. HIGH-RISE DISTRICTS

High-Rise (HR)

5.1.7. General Building (continued)

a. Lot Standards

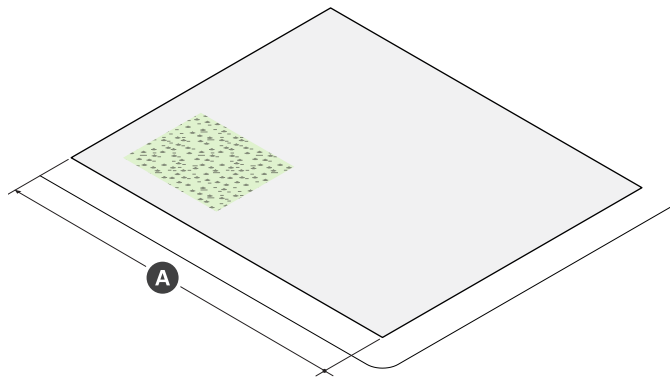

Lot Dimensions	
A LOT WIDTH (min)	30 ft

Lot Development	
LOT Coverage (max)	100%
GREEN SCORE	--
Minimum	0.20
Ideal	0.25
B OPEN SPACE (min)	15%

b. BUILDING Placement

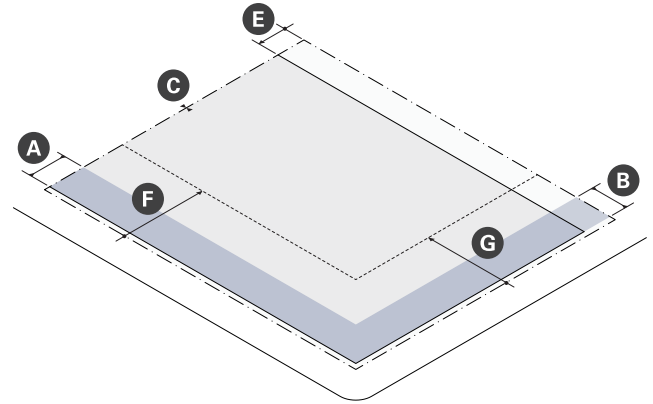

Building Setbacks	
<u>Curb Setback (min)</u>	<u>18 ft</u>
A Primary Front SETBACK (min/max)	2 ft 15 ft
B Secondary Front SETBACK (min/max)	2 ft 15 ft
C Side SETBACK (min)	--
Abutting an Alley or R-ROW	0 ft
Abutting any non-NR or -LHD	0 ft
1st - 3rd Story abutting NR or LHD	10 ft
4th - 6th Story abutting NR or LHD	30 ft
D Rear Setback (min)	--
Abutting an Alley or R-ROW	0 ft
Abutting any non-NR or -LHD	10 ft
1st - 3rd Story abutting NR or LHD	20 ft
4th - 6th Story abutting NR or LHD	30 ft

Parking Setbacks	
E Primary Front Setback (min)	30 ft
F Secondary Front Setback (min)	30 ft

5. HIGH-RISE DISTRICTS

High-Rise (HR)

5.1.8. Commercial Building (continued)

a. LOT Standards

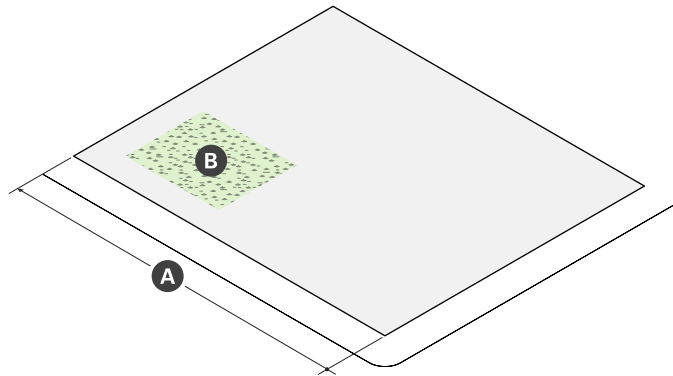

Lot Dimensions	
A LOT WIDTH (min)	30 ft

Lot Development	
LOT Coverage (max)	100%
GREEN SCORE	--
Minimum	0.20
Ideal	0.25
B OPEN SPACE (min)	15%

b. BUILDING Placement

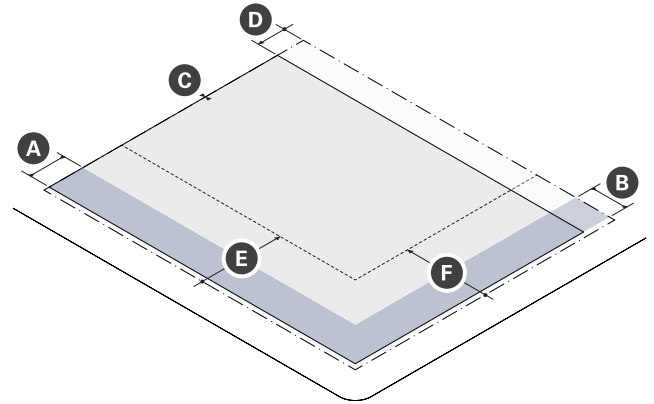

Building Setbacks	
<u>Curb Setback (min)</u>	<u>18 ft</u>
A Primary Front SETBACK (min/max)	2 ft 15 ft
B Secondary Front SETBACK (min/max)	2 ft 15 ft
C Side SETBACK (min)	--
Abutting an Alley or R-ROW	0 ft
Abutting any non-NR or -LHD	0 ft
1st - 3rd Story abutting NR or LHD	10 ft
4th - 10th Story abutting NR or LHD	30 ft
D Rear Setback (min)	--
Abutting an Alley or R-ROW	0 ft
Abutting any non-NR or -LHD	10 ft
1st - 3rd Story abutting NR or LHD	20 ft
4th - 10th Story abutting NR or LHD	30 ft

Parking Setbacks	
E Primary Front Setback (min)	30 ft
F Secondary Front Setback (min)	30 ft

5. HIGH-RISE DISTRICTS

High-Rise (HR)

5.1.9. Lab Building (continued)

a. LOT Standards

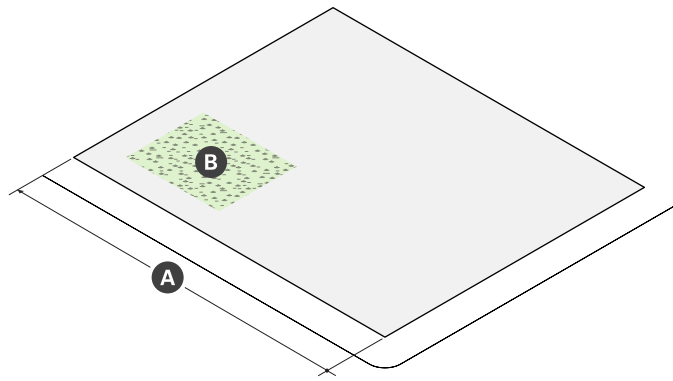

Lot Dimensions	
A LOT WIDTH (min)	30 ft

LOT Development	
LOT Coverage (max)	100%
GREEN SCORE	--
Minimum	0.20
Ideal	0.25
B OPEN SPACE (min)	15%

b. BUILDING Placement

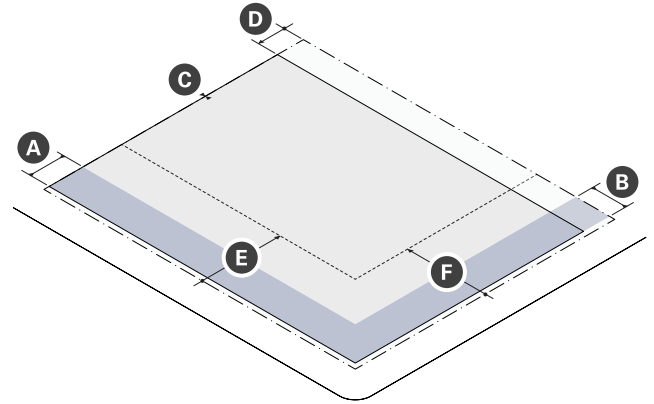

Building Setbacks	
<u>Curb Setback (min)</u>	<u>18 ft</u>
A Primary Front SETBACK (min/max)	2 ft 15 ft
B Secondary Front SETBACK (min/max)	2 ft 15 ft
C Side SETBACK (min)	--
Abutting an Alley or R-ROW	0 ft
Abutting any non-NR or -LHD	0 ft
1st - 3rd Story abutting NR or LHD	10 ft
4th - 9th Story abutting NR or LHD	30 ft
D Rear Setback (min)	--
Abutting an Alley or R-ROW	0 ft
Abutting any non-NR or -LHD	10 ft
1st - 3rd Story abutting NR or LHD	20 ft
4th - 9th Story abutting NR or LHD	30 ft

Parking Setbacks	
E Primary Front Setback (min)	30 ft
F Secondary Front Setback (min)	30 ft

5. HIGH-RISE DISTRICTS

High-Rise (HR)

5.1.10. Mid-Rise Podium Tower (continued)

a. LOT Standards

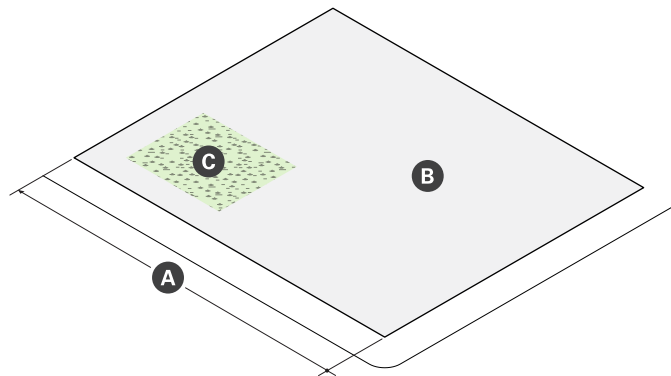

Lot Dimensions	
A LOT WIDTH (min)	150 ft

Lot Development	
LOT Coverage (max)	100%
GREEN SCORE	--
Minimum	0.20
Ideal	0.25
B OPEN SPACE (min)	15%

b. BUILDING Placement

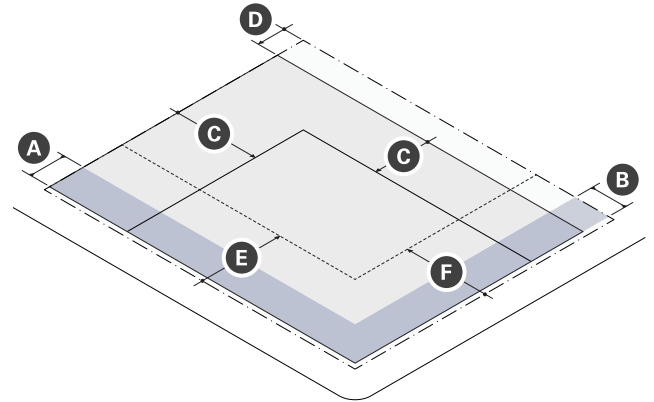

Building Setbacks	
Curb Setback (min)	18 ft
A Primary Front SETBACK (min/max)	2 ft 15 ft
B Secondary Front SETBACK (MIN/MAX)	2 ft 15 ft
C Side SETBACK (min)	--
Podium abutting an Alley or R-ROW	0 ft
Podium abutting any non-NR or -LHD	0 ft
1st - 3rd Story abutting NR or LHD	10 ft
4th - 6th Story abutting NR or LHD	30 ft
Point Tower	30 ft
Point Tower Abutting NR or LHD	60 ft
D Podium Rear Setback (min)	--
Abutting an Alley or R-ROW	0 ft
Abutting any non-NR or -LHD	10 ft
1st - 3rd Story abutting NR or LHD	20 ft
4th - 6th Story abutting NR or LHD	30 ft
POINT TOWER REAR SETBACK	30 ft
ABUTTING NR or LHD	60 ft

Parking Setbacks	
E Primary Front SETBACK (min)	30 ft
F Secondary Front SETBACK (min)	30 ft

5. HIGH-RISE DISTRICTS

High-Rise (HR)

5.1.11. Block Building (continued)

a. Lot Standards

b. BUILDING Placement

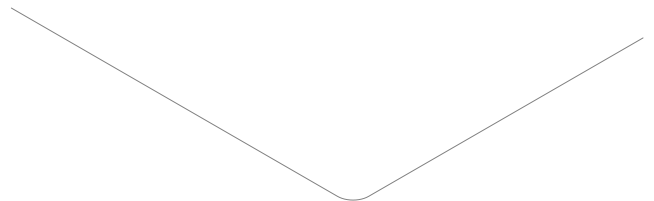
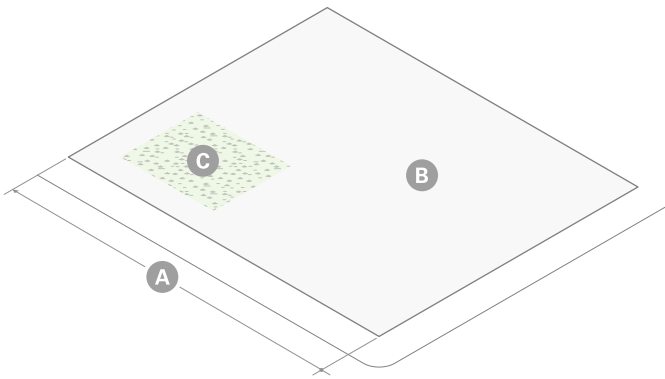

Lot Dimensions	
A Lot Width (min)	200 ft
Depth (min)	250 ft

Lot Development	
B Lot Coverage (max)	100%
GREEN SCORE	--
Minimum	0.20
Ideal	0.25
C OPEN SPACE (min)	15%

Building Setbacks	
<u>Curb Setback (min)</u>	<u>18 ft</u>
A Primary Front SETBACK (min/max)	2 ft 15 ft
B Secondary Front SETBACK	2 ft 15 ft
C Side SETBACK (min)	--
Podium abutting an Alley or R-ROW	0 ft
Podium abutting any non-NR or -LHD	0 ft
1st - 3rd Story abutting NR or LHD	10 ft
4th - 6th Story abutting NR or LHD	30 ft
Tower(s)	30 ft
Tower(s) Abutting NR or LHD	60 ft
D Podium Rear Setback (min)	--
Abutting an Alley or R-ROW	0 ft
Abutting any non-NR or -LHD	10 ft
1st - 3rd Story abutting NR or LHD	20 ft
4th - 6th Story abutting NR or LHD	30 ft
TOWER(S) REAR SETBACK	30 ft
ABUTTING NR or LHD	60 ft

Parking Setbacks	
E Primary Front SETBACK (min)	30 ft
F Secondary Front SETBACK (min)	30 ft

5. HIGH-RISE DISTRICTS

High-Rise (HR)

18. Public Realm

a. Sidewalks

~~i. When development occurs on any lot abutting a sidewalk that is less than twelve (12) feet in total width, the building must be set-back an additional distance to accommodate expansion of the abutting sidewalk must be provided to a width of at least eighteen (18) feet. The minimum and maximum front setbacks for each building type are increased accordingly:~~

i. For any lot abutting a sidewalk that is less than eighteen (18) feet in width, the frontage area must be paved to provide a sidewalk that is at least eighteen (18) feet in total width.

b. Sidewalk CURB CUTS

- i. A CURB CUT requires a permit from the City Engineer and must be compliant with all City Ordinances.
- ii. Unless otherwise specified, the City Engineer may not permit more than one (1) CURB CUT per FRONT LOT LINE, up to two (2) CURB CUTS per LOT.
- iii. CURB CUTS are prohibited along all THOROUGHFARES designated as a PEDESTRIAN STREET.
- iv. CURB CUTS must be located to minimize conflicts with pedestrians and bicyclists and must have a clear distance from fire hydrants, STREET TREES, utility poles, and other furnishings as deemed necessary by the City Engineer.
 - a). CURB CUTS for commercial or high-volume driveways should be at least one-hundred (100) feet from an UNSIGNALIZED or SIGNALIZED intersection.
 - b). CURB CUTS for residential driveways should be at least twenty (20) feet from an UNSIGNALIZED intersection and at least forty (40) feet from a SIGNALIZED intersection.
- v. The interior width of a CURB CUT (between curb stones) may be no wider than the driveway, vehicular entrance, or loading facility it serves.
- vi. A DRIVEWAY APRON may be installed only within the furnishing zone of a sidewalk and must be constructed in accordance with all standards established by relevant City Departments.
- vii. The grade, cross slope, and clear width of the walkway of a sidewalk must be maintained between the DRIVEWAY APRON and the ABUTTING driveway. The appearance of the walkway (ie. scoring pattern or paving material) must indicate that, although a vehicle may cross, the area traversed by a vehicle remains part of the sidewalk.

Figure 5.1.18 Sidewalk Curb Cuts

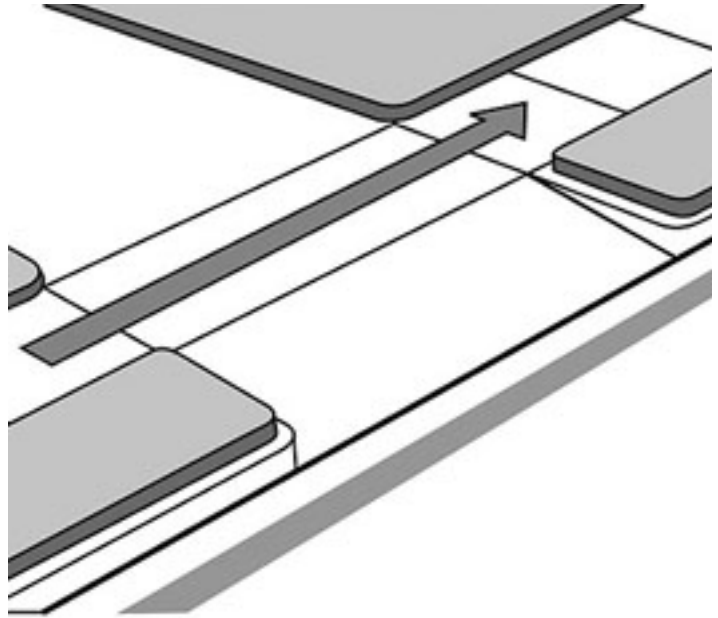

6.0 COMMERCIAL DISTRICTS

Fabrication (FAB)

6.1.7. Fabrication Building (continued)

a. Lot Standards

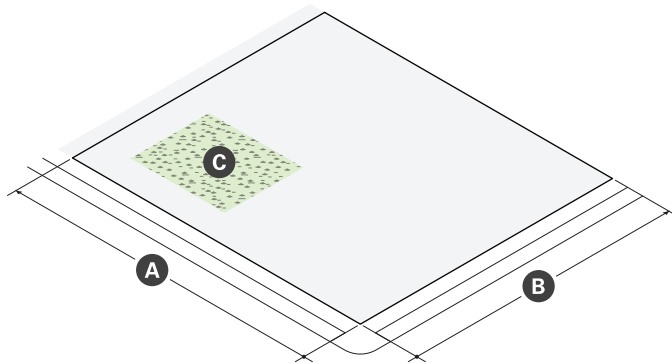

Lot Dimensions	
A Lot WIDTH (min)	30 ft

Lot Coverage	
Lot Coverage (max)	100%
Green Score (min)	0.20

b. BUILDING Placement

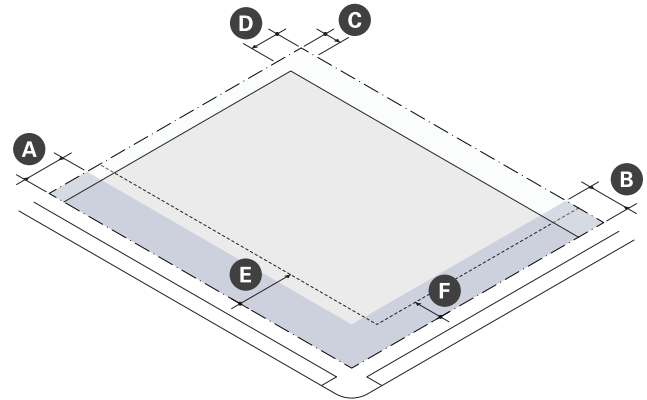

Building Setbacks		
	<u>Curb Setback (min)</u>	<u>12 ft</u>
A	Primary Front SETBACK (min/max)	2 ft 15 ft
B	Secondary Front SETBACK (min/max)	2 ft 15 ft
C	Side SETBACK (min)	0 ft
	Abutting an Alley or R-ROW	0 ft
	Abutting any non-NR or -LHD	0 ft
	1st - 3rd Story abutting NR or LHD	10 ft
	4th Story abutting NR or LHD	30 ft
D	Rear Setback (min)	--
	Abutting an Alley or R-ROW	0 ft
	Abutting any non-NR or -LHD	10 ft
	1st - 3rd Story abutting NR or LHD	20 ft
	4th Story abutting NR or LHD	30 ft

Parking Setbacks		
E	Primary Front SETBACK (min)	--
	SURFACE PARKING	20 ft
	STRUCTURED PARKING	20 ft
F	Secondary Front SETBACK (min)	--
	SURFACE PARKING	10 ft
	STRUCTURED PARKING	2 ft

14. Public Realm

- a. Sidewalks
 - ~~i. When development occurs on any lot abutting a sidewalk that is less than twelve (12) feet in total width, the building must be set back an additional distance to accommodate expansion of the abutting sidewalk must be provided to a width of at least twelve (12) feet. The minimum and maximum front setbacks for each building type are increased accordingly.~~
 - i. For any lot abutting a sidewalk that is less than twelve (12) feet in width, the frontage area must be paved to provide a sidewalk that is at least twelve (12) feet in total width.
- b. Sidewalk CURB CUTS
 - i. A CURB CUT requires a permit from the City Engineer and must be compliant with all City Ordinances.
 - ii. Unless otherwise specified, the City Engineer may not permit more than one (1) CURB CUT per FRONT LOT LINE of a LOT.
 - iii. CURB CUTS are prohibited along all THOROUGHFARES designated as a PEDESTRIAN STREET.
 - iv. CURB CUTS must be located to minimize conflicts with pedestrians and bicyclists and must have a clear distance from fire hydrants, STREET TREES, utility poles, and other furnishings as deemed necessary by the City Engineer.
 - a). CURB CUTS for commercial or high-volume driveways should be at least one-hundred (100) feet from an UNSIGNALIZED or SIGNALIZED intersection.
 - b). CURB CUTS for residential driveways should be at least twenty (20) feet from an UNSIGNALIZED intersection and at least forty (40) feet from a SIGNALIZED intersection.
 - v. The interior width of a CURB CUT (between curb stones) may be no wider than the driveway, vehicular entrance, or loading facility it serves.
 - vi. A DRIVEWAY APRON may be installed only within the furnishing zone of a sidewalk and must be constructed in accordance with all standards established by relevant City Departments.
 - vii. The grade, cross slope, and clear width of the walkway of a sidewalk must be maintained between the DRIVEWAY APRON and the ABUTTING driveway. The appearance of the walkway (ie. scoring pattern or paving material) must indicate that, although a vehicle may cross, the area traversed by a vehicle remains part of the sidewalk.

Figure 6.1.14 Sidewalk Curb Cuts

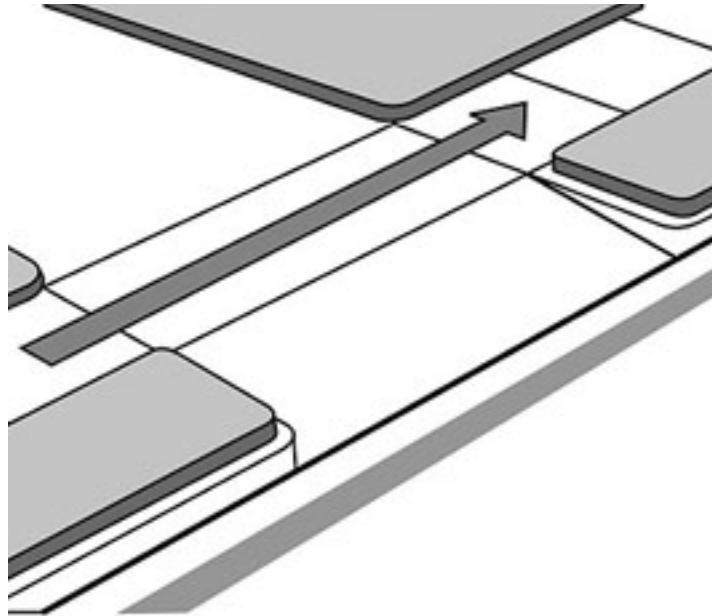

6.0 COMMERCIAL DISTRICTS

Commercial Core (CC)

6.2.7. Commercial Building (continued)

a. LOT Standards

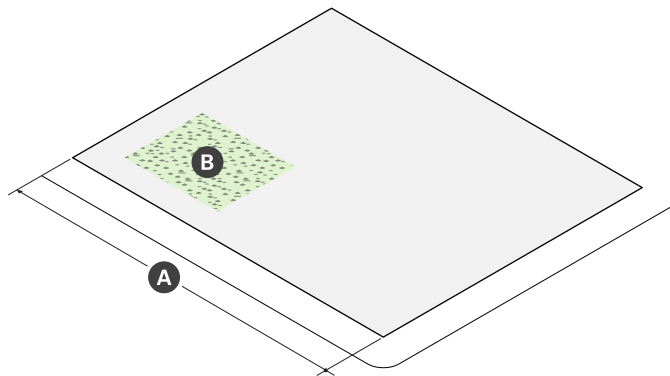

Lot Dimensions	
A LOT WIDTH (min)	30 ft

LOT Coverage	
LOT Coverage (max)	100%
GREEN SCORE	--
Minimum	0.20
Ideal	0.25
B OPEN SPACE (min)	25%

b. BUILDING Placement

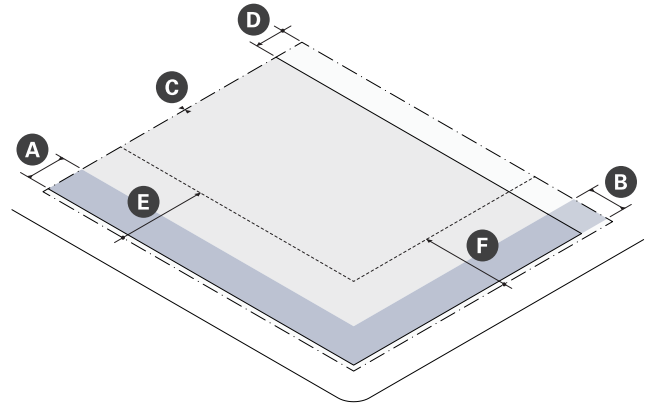

Building Setbacks		
	<u>Curb Setback (min)</u>	<u>12 ft</u>
A	Primary Front SETBACK (min/max)	2 ft 15 ft
B	Secondary Front SETBACK	2 ft 15 ft
C	Side SETBACK (min)	--
	Abutting an Alley or R-ROW	0 ft
	Abutting any non-NR or -LHD	0 ft
	1st - 3rd Story abutting NR or LHD	10 ft
	4th - 10th Story abutting NR or LHD	30 ft
D	Rear Setback (min)	--
	Abutting an Alley or R-ROW	0 ft
	Abutting any non-NR or -LHD	10 ft
	1st - 3rd Story abutting NR or LHD	20 ft
	4th - 10th Story abutting NR or LHD	30 ft

Parking Setbacks		
E	Primary Front Setback (min)	30 ft
F	Secondary Front Setback (min)	30 ft

6.0 COMMERCIAL DISTRICTS

Commercial Core (CC)

6.2.8. Lab Building (continued)

a. LOT Standards

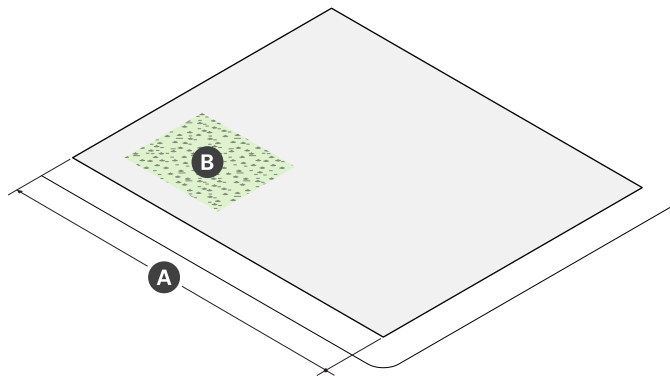

Lot Dimensions	
A LOT WIDTH (min)	30 ft

LOT Coverage	
LOT Coverage (max)	100%
GREEN SCORE	--
Minimum	0.20
Ideal	0.25
B OPEN SPACE (min)	25%

b. BUILDING Placement

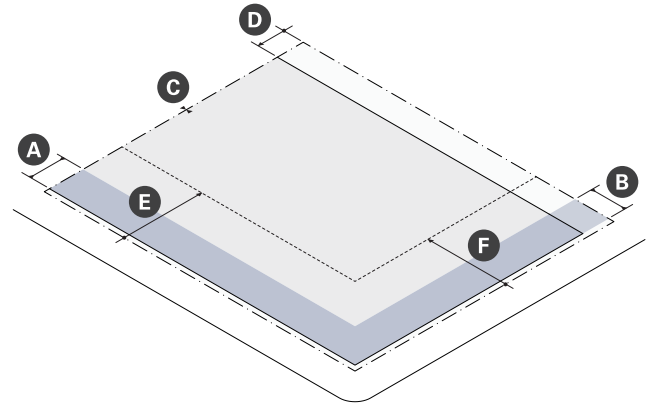

Building Setbacks		
	<u>Curb Setback (min)</u>	<u>12 ft</u>
A Primary Front SETBACK (min/max)	2 ft	15 ft
B Secondary Front SETBACK	2 ft	15 ft
C Side SETBACK (min)	--	
Abutting an Alley or R-ROW	0 ft	
Abutting any non-NR or -LHD	0 ft	
1st - 3rd Story abutting NR or LHD	10 ft	
4th - 10th Story abutting NR or LHD	30 ft	
D Rear Setback (min)	--	
Abutting an Alley or R-ROW	0 ft	
Abutting any non-NR or -LHD	10 ft	
1st - 3rd Story abutting NR or LHD	20 ft	
4+ Stories abutting NR or LHD	30 ft	

Parking Setbacks	
E Primary Front Setback (min)	30 ft
F Secondary Front Setback (min)	30 ft

6.0 COMMERCIAL DISTRICTS

Commercial Core (CC)

6.2.9. Commercial Block Building (continued)

a. LOT Standards

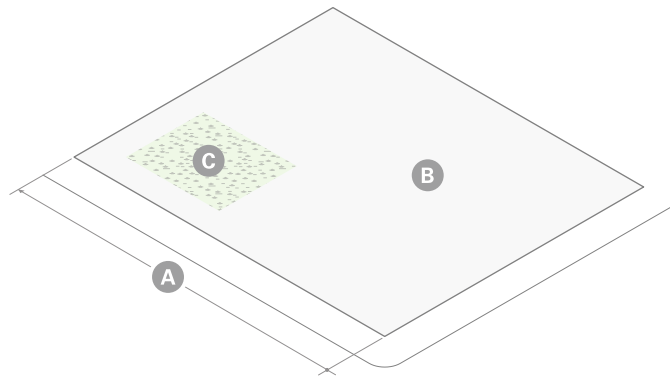

Lot Dimensions	
A LOT WIDTH (min)	200 ft
Depth (min)	250 ft

Lot Development	
LOT Coverage (max)	100%
GREEN SCORE	--
Minimum	0.20
Ideal	0.25
B OPEN SPACE (min)	25%

b. BUILDING Placement

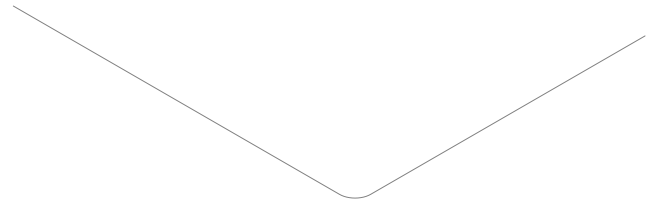

Building Setbacks	
<u>Curb Setback (min)</u>	<u>12 ft</u>
A Primary Front SETBACK (min/max)	2 ft 15 ft
B Secondary Front SETBACK	2 ft 15 ft
C Side SETBACK (min)	--
Podium abutting an Alley or R-ROW	0 ft
Podium abutting any non-NR or -LHD	0 ft
1st - 3rd Story abutting NR or LHD	10 ft
4th - 6th Story abutting NR or LHD	30 ft
Tower(s)	30 ft
Tower(s) Abutting NR or LHD	60 ft
D Podium Rear Setback (min)	--
Abutting an Alley or R-ROW	0 ft
Abutting any non-NR or -LHD	10 ft
1st - 3rd Story abutting NR or LHD	20 ft
4th - 6th Story abutting NR or LHD	30 ft
Tower(s) Rear Setback	30 ft
ABUTTING NR or LHD	60 ft

Parking Setbacks	
E Primary Front SETBACK (min)	30 ft
F Secondary Front SETBACK (min)	30 ft

6.0 COMMERCIAL DISTRICTS

Commercial Core (CC)

16. Public Realm

a. Sidewalks

~~i. When development occurs on any lot abutting a sidewalk that is less than twelve (12) feet in total width, the building must be set back an additional distance to accommodate expansion of the abutting sidewalk must be provided to a width of at least twelve (12) feet. The minimum and maximum front setbacks for each building type are increased accordingly.~~

i. For any lot abutting a sidewalk that is less than twelve (12) feet in width, the frontage area must be paved to provide a sidewalk that is at least twelve (12) feet in total width.

b. Sidewalk CURB CUTS

i. A CURB CUT requires a permit from the City Engineer and must be compliant with all City Ordinances.

ii. Unless otherwise specified, the City Engineer may not permit more than one (1) CURB CUT per FRONT LOT LINE, up to two (2) CURB CUTS per LOT.

iii. CURB CUTS are prohibited along all THOROUGHFARES designated as a PEDESTRIAN STREET.

iv. CURB CUTS must be located to minimize conflicts with pedestrians and bicyclists and must have a clear distance from fire hydrants, STREET TREES, utility poles, and other furnishings as deemed necessary by the City Engineer.

a). CURB CUTS for commercial or high-volume driveways should be at least one-hundred (100) feet from an UNSIGNALIZED or SIGNALIZED intersection.

b). CURB CUTS for residential driveways should be at least twenty (20) feet from an UNSIGNALIZED intersection and at least forty (40) feet from a SIGNALIZED intersection.

c). Multiple CURB CUTS serving the same LOT or BUILDING must be at least one hundred and fifty (150) feet apart from one another.

v. The interior width of a CURB CUT (between curb stones) may be no wider than the driveway, vehicular entrance, or loading facility it serves.

vi. A DRIVEWAY APRON may be installed only within the furnishing zone of a sidewalk and must be constructed in accordance with all standards established by relevant City Departments.

vii. The grade, cross slope, and clear width of the walkway of a sidewalk must be maintained between the DRIVEWAY APRON and the ABUTTING driveway. The appearance of the walkway (ie. scoring pattern or paving material) must indicate that, although a vehicle may cross, the area traversed by a vehicle remains part of the sidewalk.

Figure 6.2.16 Sidewalk Curb Cuts

