

2. GLOSSARY & OVERVIEW

Glossary

Day Care Center, Child	A specific use type of the Commercial Services principal use category. See §9.2.6.h.ii Child Day Care Center.
Day Care Services	A Commercial Services principal use category. See §9.2.6.h Day Care Services.
Deck	A roofless, raised platform accessible from a secondary entrance to a building that provides outdoor amenity space. A synonym for the projecting porch building component.
Deck, Roof	<u>A raised platform on the roof of a building.</u>
Demolition	The destruction or removal of fifty percent (50%) or more of the surface area of the exterior walls and roof of a building or any exploratory demolition or internal demolition that compromises the structural integrity of a building. Normal maintenance is not demolition.
Demolition, Exploratory	The removal of non-structural interior building materials prior to renovation, rehabilitation, restoration, or remodeling in order to verify the existing conditions present in otherwise unexposed areas.
Demolition, Internal	The removal of non-structural interior building materials for the purpose of renovating, rehabilitating, restoring, or remodeling interior space.
Design & Fabrication Center	A facility providing individuals and small firms access to professional manufacturing tools & equipment; classes & training; lab, workshop, and studio space; and storage for tools and supplies.
Design Services	An Arts & Creative Enterprise principal use category. See §9.2.2.e Design Services.
Desire Line	A route that pedestrians prefer to take to get from one location to another.
Development	The subdivision or land platting of a development site; the construction or modification of any principal building type, accessory building type, or other structure; the excavation, fill, or grading of land; and the establishment, change, or expansion of any use of any structure or land.
Development Site	The land area encompassed in a development proposal irrespective of the number or configuration of lots, land ownership, or municipal boundaries.
Diameter at Breast Height	The diameter of a tree trunk or the square root of the sum of each trunk squared for a multi trunk tree, measured four and one-half (4.5) feet above ground. Diameter at breast height is abbreviated as DBH.
Dispatch Service	An Auto-Oriented principal use category. See §9.2.3.b Dispatch Services.
Driveway Apron	A ramp that slopes down from the edge of the walkway of a sidewalk to the roadway surface of an abutting thoroughfare.
Dry Cleaning or Laundry Services	An Industrial principal use category. See §9.2.8.a Dry Cleaning or Laundry Services.
Dormitory or Chapter House	A specific use type of the Group Living principal use category. See §9.2.11.b.ii Dormitory or Chapter House.
Dwelling Unit	One (1) or more rooms providing separate, independent living space with lawful cooking and sanitary facilities for the exclusive use of the occupants.
Easement	A liberty, privilege, or advantage without profit, which a person(s) may have in the lands of another person(s).
Educational Services	A Commercial Services principal use category. See §9.2.6.i Educational Services.
Employer	A person or business that employs one (1) or more people for wages or salary.
Encroach	To break the plane of a vertical or horizontal regulatory limit with a structural element, so that it extends into a setback or over the sidewalk of a public right-of-way.
Encroachment	Any structural element that encroaches.
Erect	To construct, reconstruct, excavate, fill, drain, or conduct physical operations of any kind in preparation for or in pursuance of construction or reconstruction, or to move a building or structure upon a lot.
Fabrication Laboratory	A high-tech workshop that fosters innovation and invention by providing

2. GLOSSARY & OVERVIEW

Glossary

Residential Gardening	held unoccupied when not in use by that specific motor vehicle(s) or person. A specific use type of the Urban Agriculture accessory use category. See §9.2.14.d.iv Residential Gardening.
Retaining Wall	A structure designed to resist the lateral displacement of soil or other materials in order to protect property or prevent erosion.
Ribbon Driveway	A driveway with two parallel paved tracks separated by an unpaved area.
Ribbon Windows	A series of windows set side by side to form a continuous horizontal band across a facade.
Roof Line	The highest point on any building or structure where an exterior wall or parapet wall encloses roof or floor area, including floor area provided for housing mechanical equipment.
Roof, Flat	A roof with no slope greater than 2:12.
Roof, Gable	A roof sloped on two sides from a central ridge with an exterior wall (gable) enclosing each end.
Roof, Gambrel	A compound, gabled roof with two slopes on each of its sides, where the lower has a steeper slope or pitch than the upper, inclusive of English, Dutch, and Jerkin Head gambrel roofs.
Roof, Hip	A roof with four uniformly pitched or sloping sides, inclusive of kicked hip (witch's hat) and Hawaiian hip roofs.
Roof, Main	The roof of the main massing of a principal building.
Roof, Mansard	A compound, four sided roof where each side has two slopes, where the lower has a very steep, almost vertical, slope or pitch, dormer windows, and eaves extending with a radius or kick, rather than a flat projection.
Roof, Shed	<u>A roof with only one slope.</u>
Rooming House	A specific use type of the Group Living principal use category. See §9.2.11.b.v Rooming House.
Rooming Unit	One (1) or more rooms providing separate, independent living facilities for use by one (1) or two (2) human beings living together as a single household without both lawful cooking and sanitary facilities for the exclusive use of the occupants inside the rooming unit.
Runoff Coefficient	A number relating the amount of storm water runoff to the amount of precipitation received. A larger value indicates low permeability and higher storm water runoff and a lower value indicates higher permeability and lower storm water runoff.
Salvage Yard	An Industrial principal use category. See §9.2.8.f Salvage Yard.
Sand-Based Structural Soil System	Open graded crushed stone over sand-based structural soil.
Self-Storage	A specific use type of the Moving or Storage Services principal use category. See §9.2.8.d.i Self Storage.
Setback	A horizontal distance from a particular point of reference to the location of a principal or accessory building or an accessory structure.
Shared Workspace & Arts Education	An Arts & Creative Enterprise principal use category. See §9.2.2.f Shared Workspace & Arts Education.
Shrub	A multi-stemmed, woody plant with a five-gallon container size when planted.
Sign	Any permanent or temporary name, identification, description, emblem, logo, structure, or device, that is illuminated or non-illuminated; visible or intended to be visible from any public place; and directs attention to a person, product, place, activity, institution, business, organization, activity, or service including any letter, numeral, character, figure, emblem, painting, illustration, banner, pennant, placard, or temporary sign designed to advertise, identify, solicit, or convey information. Signs include devices designed to attract the eye by intermittent or repeated motion and any permanently installed or situated merchandise, including any banner, pennant, placard, or temporary sign, with the exception of window displays. Flags of the United States and the Commonwealth of Massachusetts are not signs.

3 RESIDENCE DISTRICTS

NEIGHBORHOOD RESIDENCE
URBAN RESIDENCE



3. RESIDENCE DISTRICTS

Neighborhood Residence (NR)

e. Entry Canopy

- i. An entry canopy is a wall-mounted structure that provides shade and weather protection over the entrance of a BUILDING.

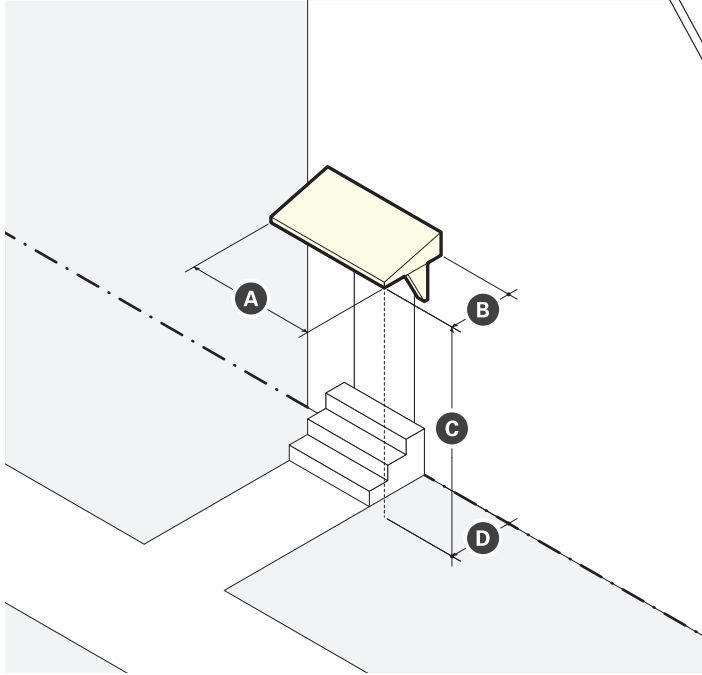

Dimensions	
A Width (min)	See ii. Standards
B Projection (max)	3 ft
C Clearance (min)	8 ft
D SETBACK ENCROACHMENT (max)	–
Front	100%
Side & Rear	0 ft

- ii. Standards
 - a). Entry canopies must be visually supported by brackets, cables, or rods.
 - b). The width of an entry canopy must be equal to or greater than the width of the doorway surround, trim, or exterior casing it is mounted above.

f. Stoop

- i. A stoop is a front, side, or rear facing set of stairs with a landing that provides access to a ground story or basement entrance of a building.

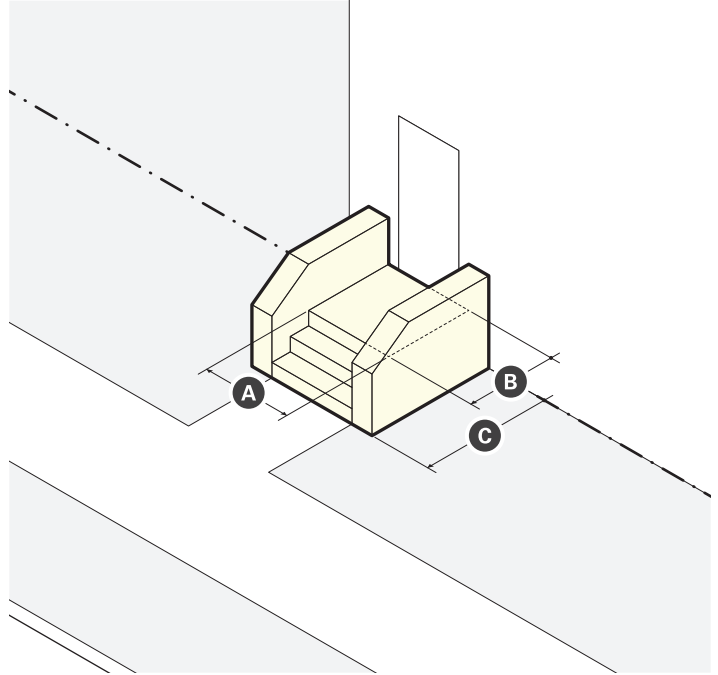

Dimensions	
A Landing Width (min)	4 ft
B Landing Projection (min)	4 ft
C Setback Encroachment (max)	–
Front	100%
Side & Rear	0 ft

- ii. Standards
 - a). Stairs may be recessed into the building facade when the building is set back four (4) feet or less.
 - b). Stairs are not permitted to encroach onto any abutting sidewalk.

3. RESIDENCE DISTRICTS

Neighborhood Residence (NR)

g. Portico

- i. A portico is a front facing, single or multi-level platform projecting from the facade of a building and providing access to a ground story entrance.

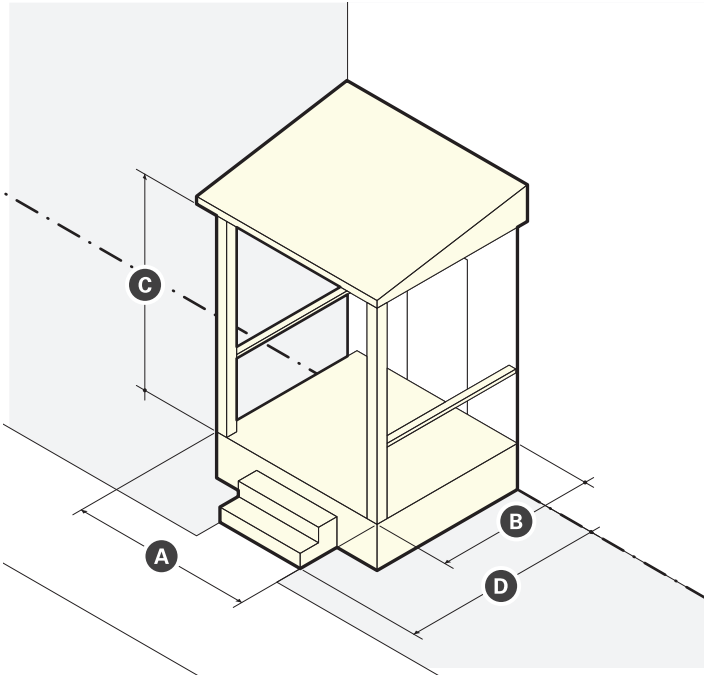

Dimensions	
A <u>Landing Width (max)</u>	4 ft
B <u>Landing Projection (min)</u>	4 ft
<u>Floors (max)</u>	1 per story of the building
D <u>Setback Encroachment (max)</u>	=
<u>Front</u>	100%
<u>Side & Rear</u>	0 ft

- ii. Standards
 - a). Stairs are not permitted to encroach onto any abutting sidewalk.
 - b). The roof of any portico may not project above the roofline of the main massing.
 - c). Stairs providing access between the levels of a multi-level portico are prohibited.

h. Projecting Porch

- i. A porch is a front, side, or rear facing single or multi-level platform accessed from an entrance of a building.

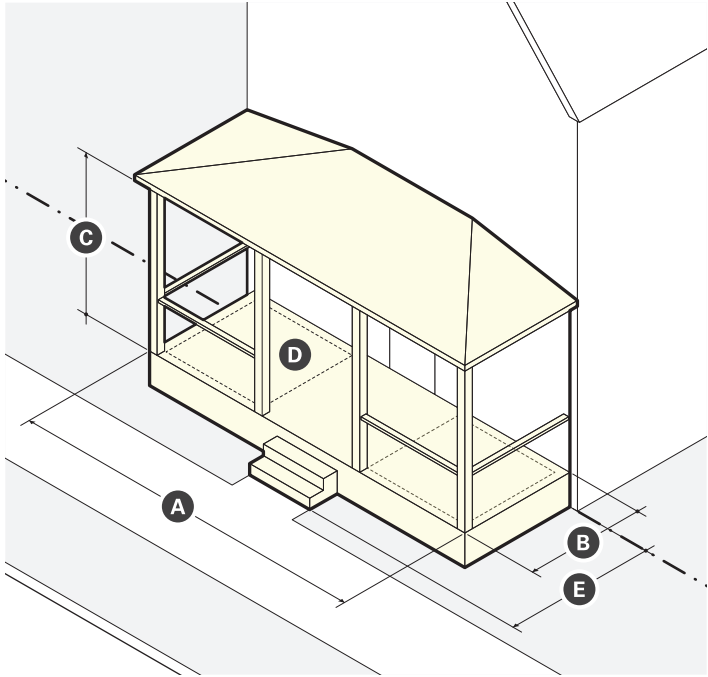

Dimensions	
A <u>Width (min)</u>	=
<u>Front</u>	12 ft
<u>Side & Rear</u>	4 ft
B <u>Projection (min)</u>	=
<u>Front</u>	6 ft
<u>Side & Rear</u>	4 ft
D <u>Furniture Area, Front Porch (min)</u>	6 ft x 6 ft
<u>Floors (max)</u>	1 per story of the building
D <u>Setback Encroachment (max)</u>	=
<u>Front</u>	100%
<u>Side & Rear</u>	0 ft

- ii. Standards
 - a). Stairs are not permitted to encroach onto any abutting sidewalk.
 - b). Projecting porches may be screened, but permanent enclosure to create habitable space is prohibited.
 - c). The roof of any projecting porch may not project above the roofline of the main massing.

3. RESIDENCE DISTRICTS

Neighborhood Residence (NR)

i. Engaged Porch

- i. An engaged porch is a front facing ground story porch that provides access to an encroaching mud room or entry foyer.

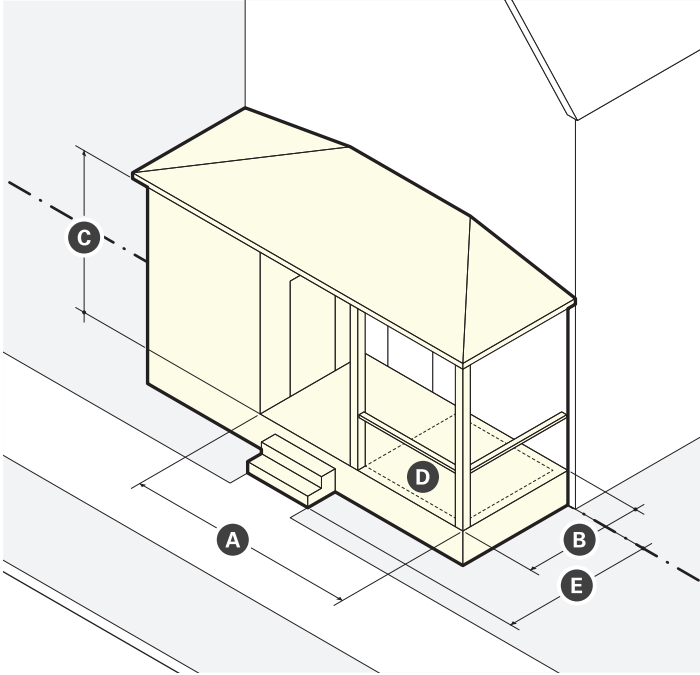

Dimensions	
A <u>Width (min)</u>	<u>12 ft</u>
B <u>Projection (min)</u>	<u>6 ft</u>
D <u>Furniture Area (min)</u>	<u>6 ft x 6 ft</u>
<u>Mud Room/Foyer Width (max)</u>	<u>40% of main massing width</u>
E <u>Setback Encroachment (max)</u>	<u>=</u>
<u>Front</u>	<u>100%</u>
<u>Side & Rear</u>	<u>0 ft</u>

- ii. Standards
 - a). Stairs are not permitted to encroach onto any abutting sidewalk.
 - b). Engaged porches are prohibited for upper stories, but may be combined with upper story projecting porches to create a multi-level combination porch with a single ground story mud room.

j. Bay Window

- i. A bay window is an assembly of windows projecting from a building to provide additional HABITABLE space, increased light, multi-directional views, and ARTICULATION to an exterior wall.

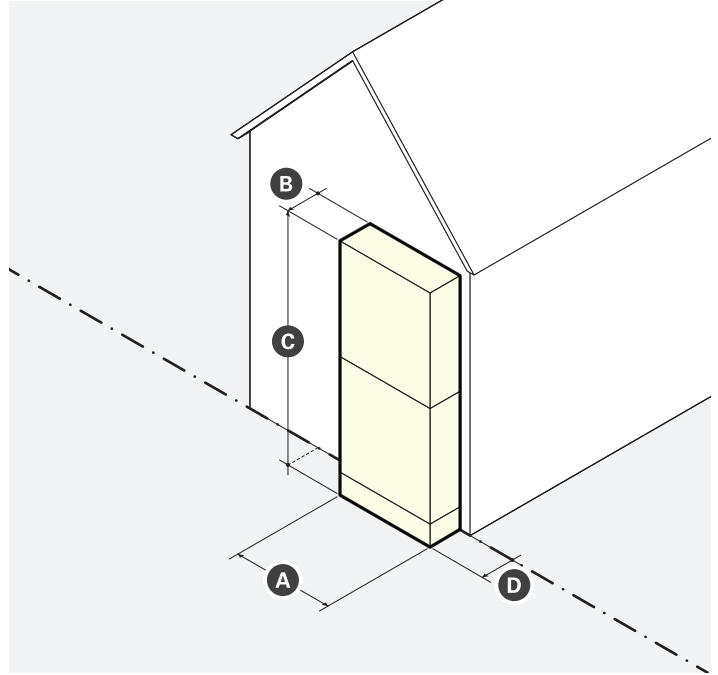

Dimensions	
A <u>Width (max)</u>	<u>16 ft</u>
B <u>Projection (max)</u>	<u>3 ft</u>
C <u>Height (max)</u>	<u>Height of BUILDING in Stories</u>
D <u>SETBACK ENCROACHMENT (max)</u>	<u>-</u>
<u>Front</u>	<u>3 ft</u>
<u>Side & Rear</u>	<u>0 ft</u>

- ii. Standards
 - a). Bay windows, including box and bow windows, must include at least three (3) windows for
 - b). each story of the bay window.
 - c). The cumulative width of multiple bays may equal up to fifty percent (50%) of the width of the exterior wall from which the bays project.
 - d). Bay windows projecting over the sidewalk of a public THOROUGHFARE must have at least two (2) stories of CLEARANCE and be compliant with all City Ordinances.
 - e). Bay windows may have integrated recessed balconies, terraces, or roof decks.

k. Gable Dormer

- i. A gable dormer is a window space with a GABLE, HIP, or arched roof that projects perpendicularly from a pitched roof. Dormer windows provide light to the HABITABLE space of a half-STORY.

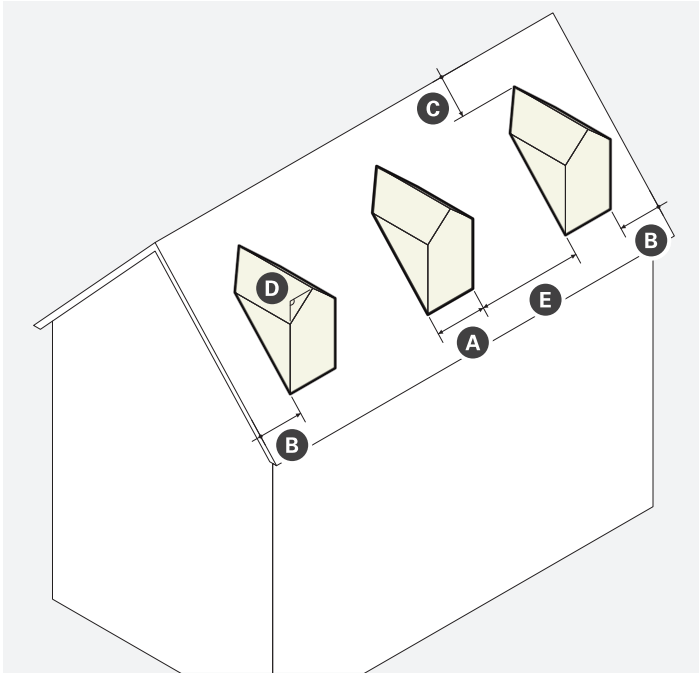

l. Shed Dormer

- i. A shed dormer is window space with a shed roof that projects perpendicularly from a pitched roof. Shed dormers provide light and additional HABITABLE space to a half-STORY.

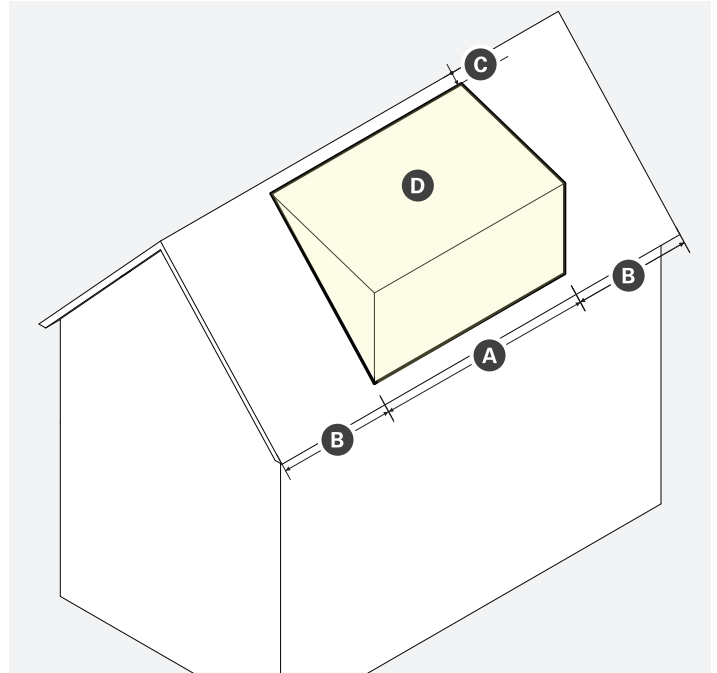

Dimensions	
A Width (max)	window(s) width +18 in of wall
Side Wall SETBACK (min)	–
Roof with eave	0 ft
Roof without eave	1 ft
B Facade & Rear Wall SETBACK (min)	3 ft
C Ridge SETBACK (min)	1 ft
Roof Slope (min)	4:12 (18.43°)
D Dormer Separation (min)	50% of width

Dimensions	
A Width (max)	window(s) width +36 in of wall
Side Wall SETBACK (min)	–
Roof with eave	0 ft
Roof without eave	1 ft
B Facade & Rear Wall SETBACK (min)	3 ft
C Ridge SETBACK (min)	1 ft
D Roof Slope (min)	4:12 (18.43°)
Dormer Separation (min)	50% of width

- ii. Standards
 - a). The face wall of a gable dormer may not project beyond the exterior wall of the BUILDING and may not interrupt the eave of the roof.
 - b). Gable dormers may be combined with a shed dormer(s) to create a Nantucket dormer.
 - c). The cumulative width of a single, multiple, or attached combinations of dormers may equal up to fifty percent (50%) of the eave/ridge length of the roof.
 - d). Gable dormers are exempt from the minimum required roof slope when combined with a mansard roof.

- ii. Standards
 - a). The face wall of a shed dormer may not project beyond the exterior wall of the BUILDING and may not interrupt the eave of the roof.
 - b). Shed dormers may be combined with a dormer window(s) to create a Nantucket dormer.
 - c). The cumulative width of a single, multiple, or attached combinations of dormers may equal up to fifty percent (50%) of the eave/ridge length of the roof.

3. RESIDENCE DISTRICTS

Urban Residence (UR)

e. Entry Canopy

- i. An entry canopy is a wall-mounted STRUCTURE that provides shade and weather protection over the entrance of a BUILDING.

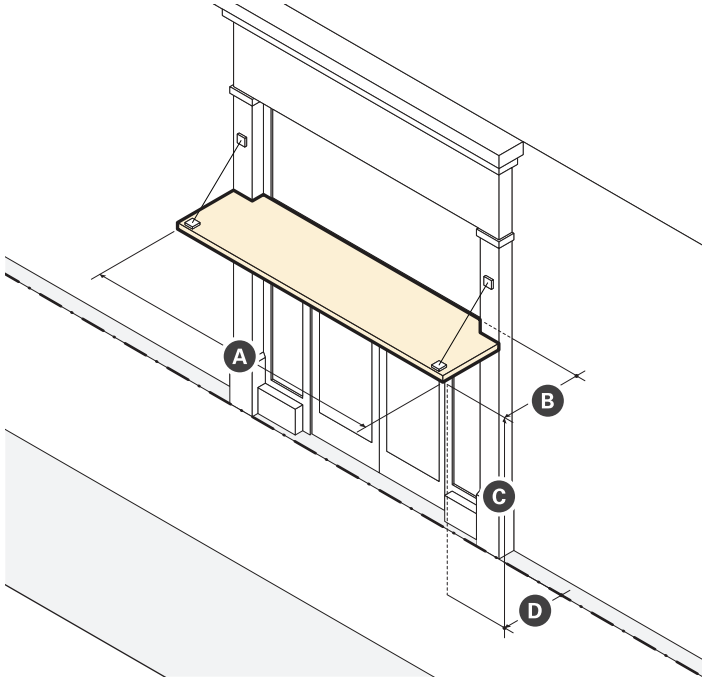

Dimensions	
A Width (min)	See ii. Standards
B Projection (max)	3 ft
C Clearance (min)	8-ft clear
D SETBACK ENCROACHMENT (max)	--
Front	100%
Side	0 ft
Rear	0 ft

- ii. Standards
 - a). Entry canopies must be visually supported by brackets, cables, or rods.
 - b). The width of an entry canopy must be equal to or greater than the width of the doorway surround or exterior casing it is mounted over.

f. Stoop

- i. A stoop is a front, side, or rear facing set of stairs with a landing providing access to a ground story or basement entrance of a building.

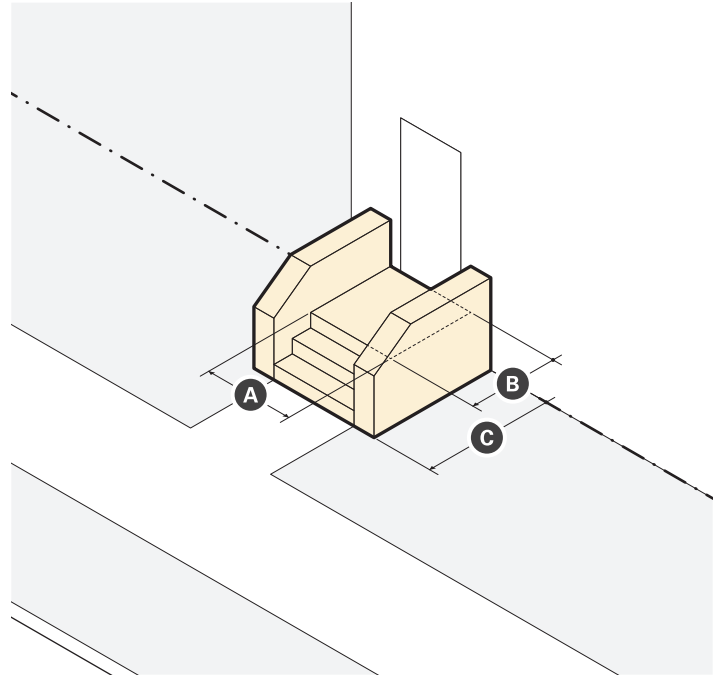

Dimensions	
A Landing Width (min)	4 ft
B Landing Projection (min)	4 ft
C Setback Encroachment (max)	--
Front	100%
Side & Rear	0 ft

- ii. Standards
 - a). Stairs may be recessed into the building facade when the building is set back four (4) feet or less.
 - b). Stairs are not permitted to encroach onto any abutting sidewalk.

g. Portico

- i. A portico is a front facing, single or multi-level platform projecting from the facade of a building and providing access to a ground story entrance.

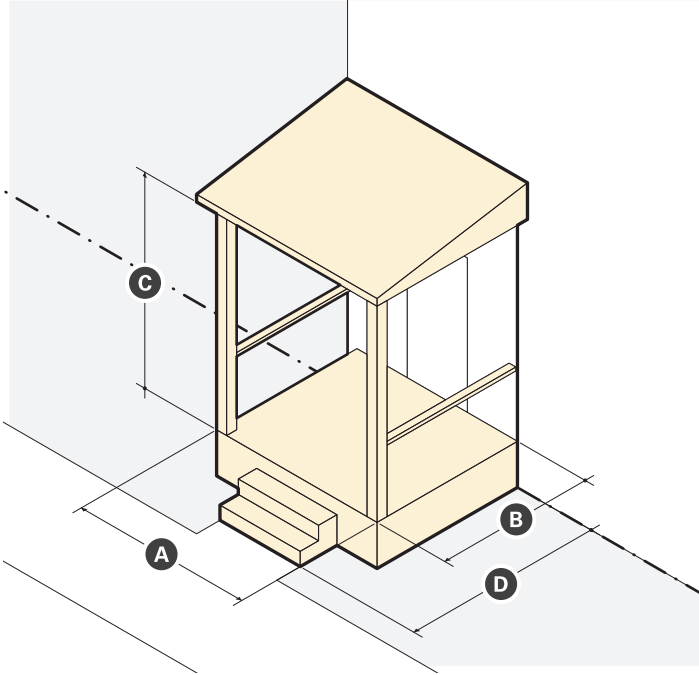

Dimensions	
A <u>Landing Width (max)</u>	<u>4 ft</u>
B <u>Landing Projection (min)</u>	<u>4 ft</u>
<u>Floors (max)</u>	<u>1 per story of the building</u>
D <u>Setback Encroachment (max)</u>	<u>=</u>
<u>Front</u>	<u>100%</u>
<u>Side & Rear</u>	<u>0 ft</u>

- ii. Standards
 - a). Stairs are not permitted to encroach onto any abutting sidewalk.
 - b). The roof of any portico may not project above the roofline of the main massing.

h. Projecting Porch

- i. A porch is a front, side, or rear facing single or multi-level platform accessed from an entrance of a building.

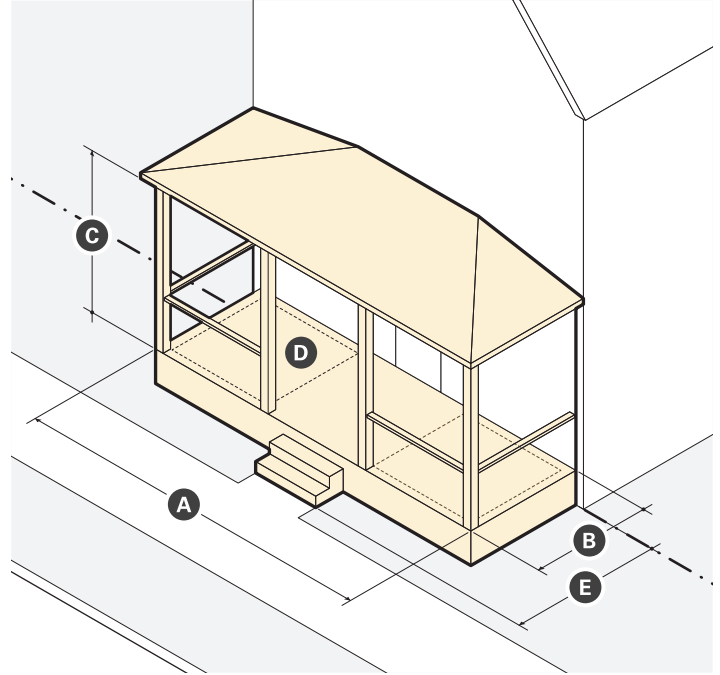

Dimensions	
A <u>Width (min)</u>	<u>=</u>
<u>Front</u>	<u>12 ft</u>
<u>Side & Rear</u>	<u>4 ft</u>
B <u>Projection (min)</u>	<u>=</u>
<u>Front</u>	<u>6 ft</u>
<u>Side & Rear</u>	<u>4 ft</u>
D <u>Furniture Area, Front Porch (min)</u>	<u>6 ft x 6 ft</u>
<u>Floors (max)</u>	<u>1 per story of the building</u>
D <u>Setback Encroachment (max)</u>	<u>=</u>
<u>Front</u>	<u>100%</u>
<u>Side & Rear</u>	<u>0 ft</u>

- ii. Standards
 - a). Stairs are not permitted to encroach onto any abutting sidewalk.
 - b). Projecting porches may be screened, but permanent enclosure to create habitable space is prohibited.
 - c). The roof of any projecting porch may not project above the roofline of the main massing.

3. RESIDENCE DISTRICTS

Urban Residence (UR)

i. Lobby Entrance

- i. A lobby entrance is a non-load bearing assembly of entry doors and windows providing access and light to the lobby of a building.

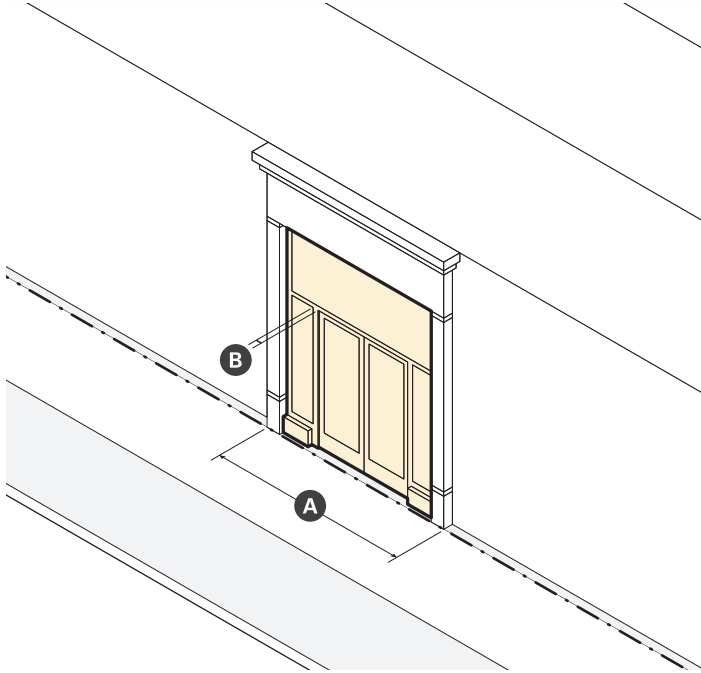

Dimensions	
A Width (max)	30 ft
B Recessed Entrance Width (max)	15 ft
Recessed Entrance Depth (max)	5 ft

- ii. Standards
 - a). Lobby entrances must be well-defined, clearly visible, and universally accessible from the abutting sidewalk.
 - b). Lobby entrances should be made clearly identifiable using a difference in design from the rest of the facade.
 - c). Lobby entrances must include an awning or entry canopy above the principal entrance to provide weather protection.
 - d). When a lobby entrance is set back from the front lot line, the frontage must be paved to match the abutting sidewalk.

j. Bay Window

- i. A bay window is an assembly of windows projecting from a building to provide additional habitable space, increased light, multi-directional views, and articulation to an exterior wall.

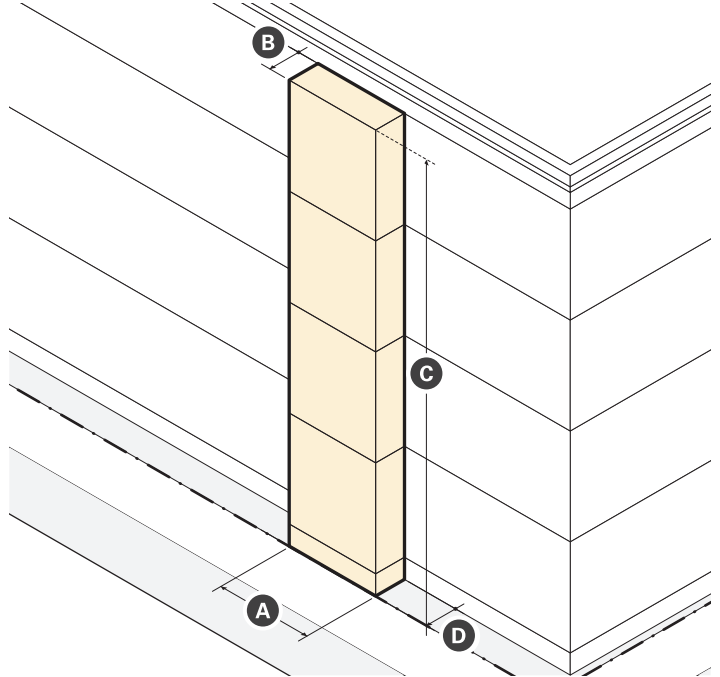

Dimensions	
A Width (max)	16 ft
B Projection (max)	3 ft
C Height (max)	Height of Building in Stories
D SETBACK ENCROACHMENT (max)	–
Front	3 ft
Side	0 ft
Rear	0 ft

- ii. Standards
 - a). Bay windows, including box and bow windows, must include at least three (3) windows for each story of the bay window.
 - b). The cumulative width of multiple bays may equal up to fifty percent (50%) of the width of the exterior wall from which the bays project.
 - c). Bays projecting over the sidewalk of a public thoroughfare must have at least two (2) stories of clearance and be compliant with all City Ordinances.
 - d). Bay windows may have integrated recessed balconies, terraces, or roof decks.

k. Balcony

- i. A balcony is a front, side, or rear facing upper story platform with a railing accessed from an entrance of a building and providing outdoor AMENITY SPACE.

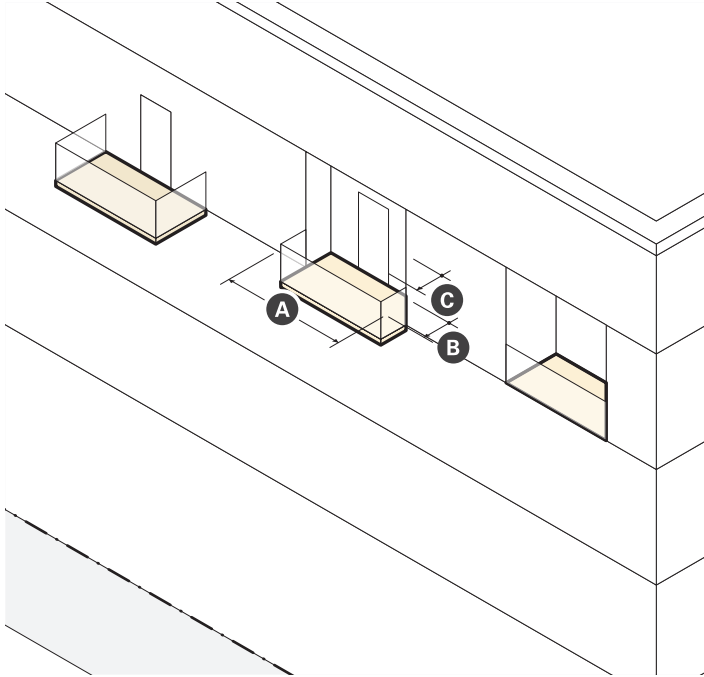

Dimensions	
A Width (min)	5 ft
B Depth (min)	5 ft
Area (min)	50 sf
Clearance (min)	10 ft
C SETBACK ENCROACHMENT (max)	–
Front	100%
Side	0 ft
Rear	0 ft

- ii. Standards
 - a). Balconies may be recessed, projecting, a combination of the two, or terraced as part of the roof of a portico, porch, or bay.
 - b). Balconies that project over any public sidewalk require compliance with all City Ordinances.
 - c). Front balconies must permit visual supervision of the public realm through the posts and rails. Side and rear balconies ABUTTING the NR district must include sight-obscuring visual screening so that it is at least fifty percent (50%) opaque.

l. Gable Dormer

- i. A gable dormer is a window space with a GABLE, HIP, or arched roof that projects perpendicularly from a pitched roof. Dormer windows provide light to the HABITABLE space of a half-STORY.

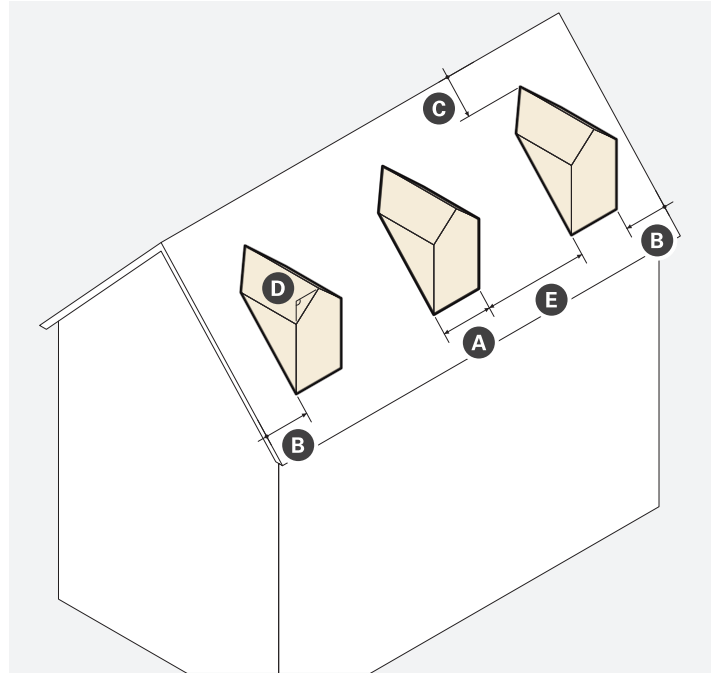

Dimensions	
A Width (max)	window(s) width +18 in of wall
Side Wall SETBACK (min)	–
Roof with eave	0 ft
Roof without eave	1 ft
B Facade & Rear Wall SETBACK (min)	3 ft
C Ridge SETBACK (min)	1 ft
D Roof Slope (min)	4:12 (18.43°)
E Dormer Separation (min)	50% of width

- ii. Standards
 - a). The face wall of a gable dormer may not project beyond the exterior wall of the BUILDING and may not interrupt the eave of the roof.
 - b). Gable dormers may be combined with a shed dormer(s) to create a Nantucket dormer.
 - c). The cumulative width of a single, multiple, or attached combinations of dormers may equal up to fifty percent (50%) of the eave/ridge length of the roof.
 - d). Gable dormers are exempt from the minimum required roof slope when combined with a mansard roof.

4 MID-RISE DISTRICTS

- MID-RISE 3
- MID-RISE 4
- MID-RISE 5
- MID-RISE 6



4. MID-RISE DISTRICTS

Mid-Rise 3 (MR3)

i. Stoop

- i. A stoop is a front, side, or rear facing set of stairs with a landing providing access to a ground story or basement entrance of a building.

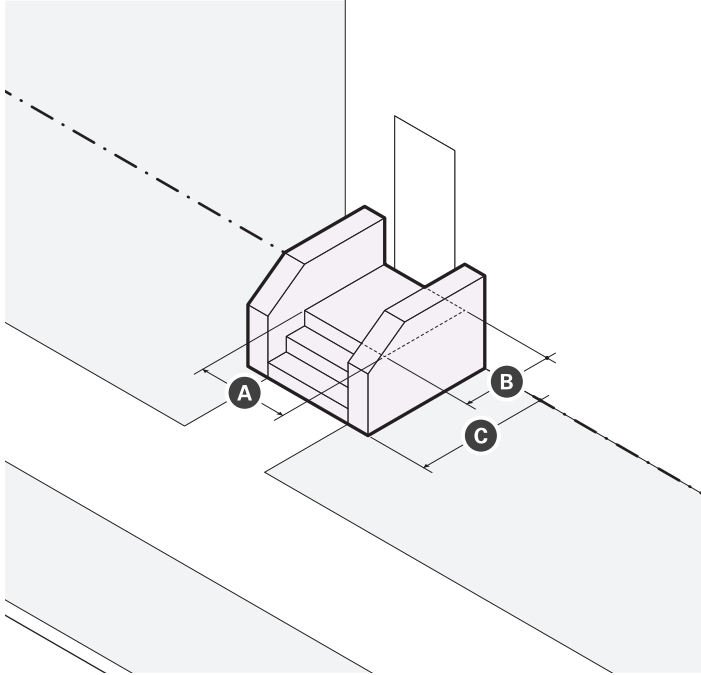

Dimensions	
A Landing Width (min)	4 ft
B Landing Projection (min)	4 ft
C Setback Encroachment (max)	=
Front	100%
Side & Rear	0 ft

- ii. Standards
 - a). Stairs may be recessed into the building facade when the building is set back four (4) feet or less.
 - b). Stairs are not permitted to encroach onto any abutting sidewalk.

j. Bay Window

- i. A bay window is an assembly of windows projecting from a building to provide additional HABITABLE space, increased light, multi-directional views, and ARTICULATION to an exterior wall.

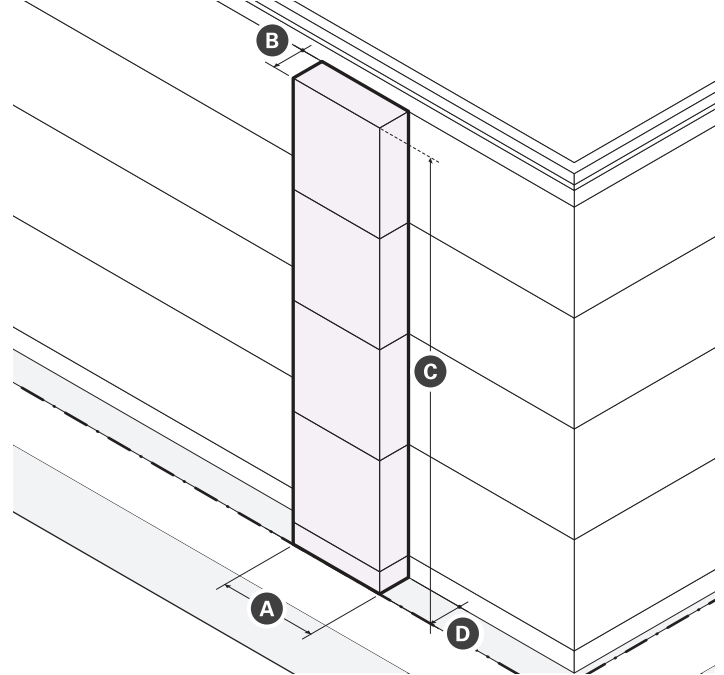

Dimensions	
A Width (max)	16 ft
B Projection (max)	3 ft
C Height (max)	Height of BUILDING in Stories
D Setback Encroachment (max)	=
Front	3 ft
Side	0 ft
Rear	0 ft
Fenestration (min)	60%

- ii. Standards
 - a). Bay windows, including box and bow windows, must include at least three (3) windows for each story of the bay window.
 - b). The cumulative width of multiple bays may equal up to fifty percent (50%) of the width of the exterior wall from which the bays project.
 - c). Bays projecting over the sidewalk of a public THOROUGHFARE must have at least two (2) stories of CLEARANCE and be compliant with all City Ordinances.
 - d). Bay windows may have integrated recessed balconies, terraces, or roof decks.

k. Balcony

- i. A balcony is a front, side, or rear facing upper story platform with a railing accessed from an entrance of a building and providing outdoor AMENITY SPACE.

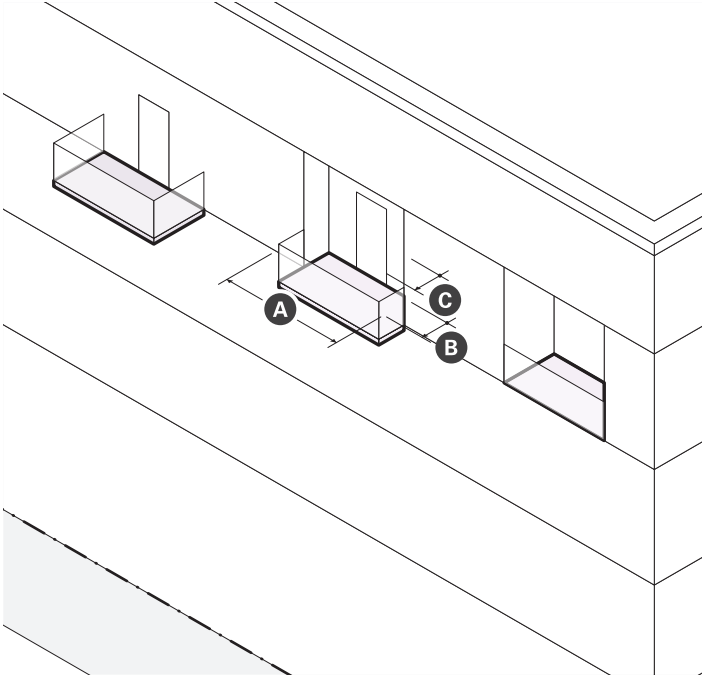

Dimensions	
A Width (min)	5 ft
B Depth (max)	5 ft
D Area (min)	50 sf
Clearance (min)	10 ft
Permitted Front SETBACK ENCROACHMENT (max)	6 ft

- ii. Standards
 - a). Balconies may be recessed, projecting, a combination of the two, or terraced as part of the roof of a portico, porch, or bay.
 - b). A balcony that projects over the sidewalk of a public THOROUGHFARE requires compliance with all City Ordinances.
 - c). The guard rail of any balcony oriented toward a FRONT LOT LINE must permit visual supervision of the PUBLIC REALM through the posts and rails.
 - d). The guard rail of any balcony oriented toward a side OF REAR LOT LINE ABUTTING the NR district must include sight-obscuring visual screening so that it is at least fifty percent (50%) opaque.

l. Arcade

- i. An arcade is a pedestrian walkway covered by the upper floors of a building. The GROUND STORY FACADE is SETBACK and upper floors are supported by a colonnade or supports.

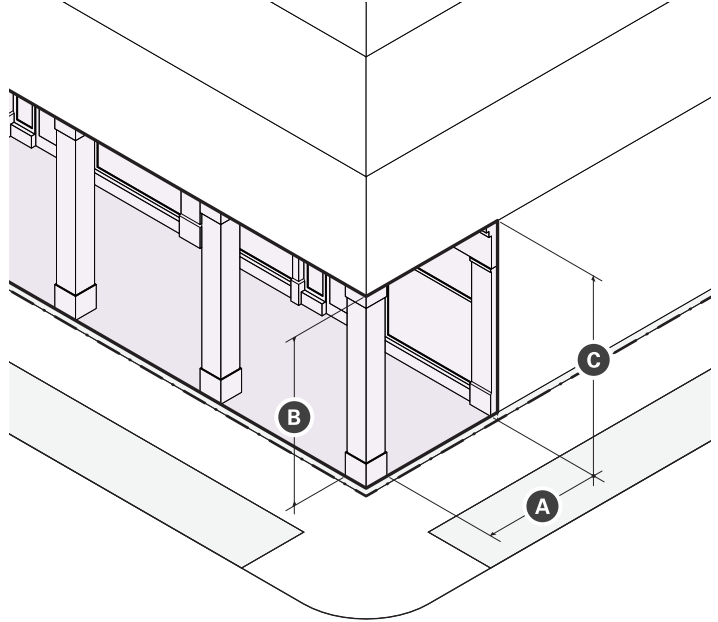

Dimensions		
A Depth (min/max)	10 ft	15 ft
B Height (max)	1 STORY	
C Clearance (min/max)	14 ft	24 ft

- ii. Standards
 - a). Arcades must extend the entire width of a building and must have a consistent depth.
 - b). Support columns or PIERS may be spaced no farther apart than they are tall.
 - c). Arcades are considered part of the building for the purpose of measuring FACADE build out.
 - d). Arcades may be combined only with storefront and lobby entrance frontages.
 - e). The finished ceiling of an arcade interior may be arched or flat, but must have a greater CLEARANCE than the openings between columns OR PIERS.

4. MID-RISE DISTRICTS

Mid-Rise 4 (MR4)

i. Stoop

- i. A stoop is a front, side, or rear facing set of stairs with a landing providing access to a ground story or basement entrance of a building.

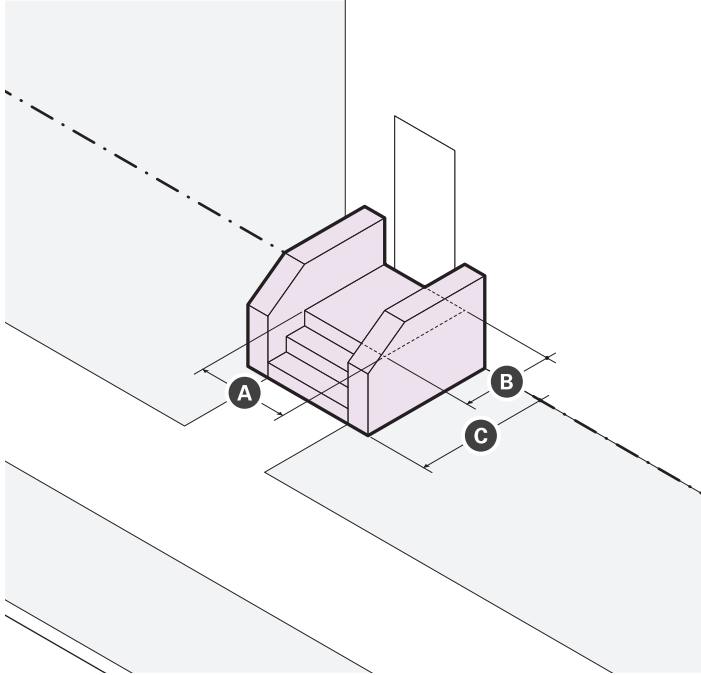

Dimensions	
A Landing Width (min)	4 ft
B Landing Projection (min)	4 ft
C Setback Encroachment (max)	=
Front	100%
Side & Rear	0 ft

- ii. Standards
 - a). Stairs may be recessed into the building facade when the building is set back four (4) feet or less.
 - b). Stairs are not permitted to encroach onto any abutting sidewalk.

j. Bay Window

- i. A bay window is an assembly of windows projecting from a building to provide additional HABITABLE space, increased light, multi-directional views, and ARTICULATION to an exterior wall.

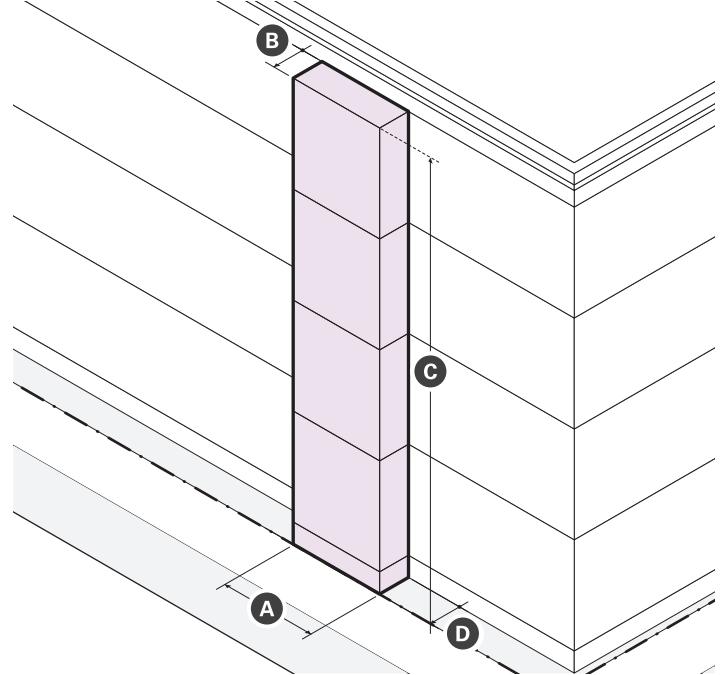

Dimensions	
A Width (max)	16 ft
B Projection (max)	3 ft
C Height (max)	Height of BUILDING in Stories
D Setback Encroachment (max)	=
Front	3 ft
Side	0 ft
Rear	0 ft
Fenestration (min)	60%

- ii. Standards
 - a). Bay windows, including box and bow windows, must include at least three (3) windows for each story of the bay window.
 - b). The cumulative width of multiple bays may equal up to fifty percent (50%) of the width of the exterior wall from which the bays project.
 - c). Bays projecting over the sidewalk of a public THOROUGHFARE must have at least two (2) stories of CLEARANCE and be compliant with all City Ordinances.
 - d). Bay windows may have integrated recessed balconies, terraces, or roof decks.

k. Balcony

- i. A balcony is a front, side, or rear facing upper story platform with a railing accessed from an entrance of a building and providing outdoor AMENITY SPACE.

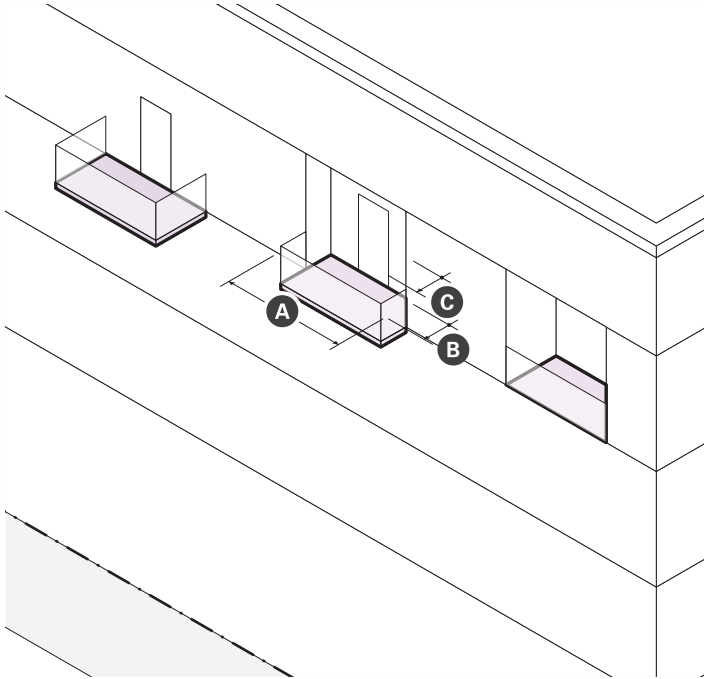

Dimensions	
A Width (min)	5 ft
B Depth (max)	5 ft
D Area (min)	50 sf
Clearance (min)	10 ft
Permitted Front SETBACK ENCROACHMENT (max)	6 ft

- ii. Standards
 - a). Balconies may be recessed, projecting, a combination of the two, or terraced as part of the roof of a portico, porch, or bay.
 - b). A balcony that projects over the sidewalk of a public THOROUGHFARE requires compliance with all City Ordinances.
 - c). The guard rail of any balcony oriented toward a FRONT LOT LINE must permit visual supervision of the PUBLIC REALM through the posts and rails.
 - d). The guard rail of any balcony oriented toward a side OF REAR LOT LINE ABUTTING the NR district must include sight-obscuring visual screening so that it is at least fifty percent (50%) opaque.

l. Arcade

- i. An arcade is a pedestrian walkway covered by the upper floors of a building. The GROUND STORY FACADE is SETBACK and upper floors are supported by a colonnade or supports.

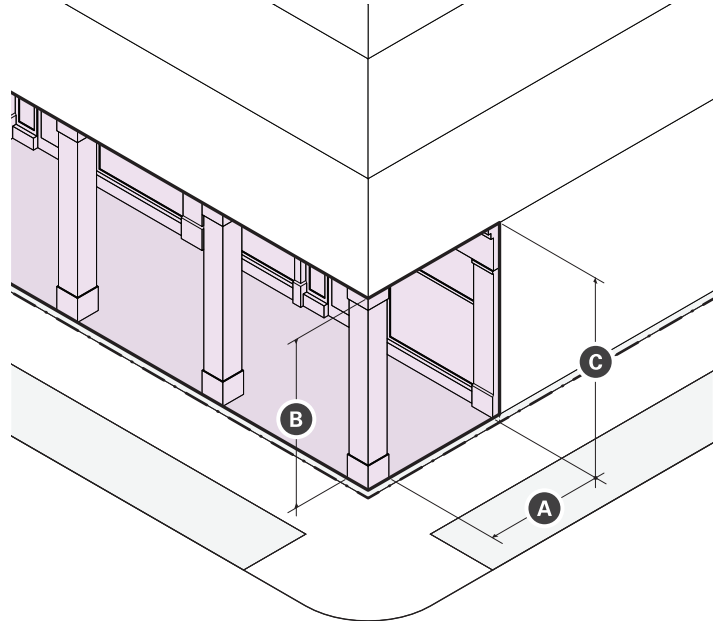

Dimensions		
A Depth (min/max)	10 ft	15 ft
B Height (max)	1 STORY	
C Clearance (min/max)	14 ft	24 ft

- ii. Standards
 - a). Arcades must extend the entire width of a building and must have a consistent depth.
 - b). Support columns or PIERS may be spaced no farther apart than they are tall.
 - c). Arcades are considered part of the building for the purpose of measuring FACADE build out.
 - d). Arcades may be combined only with storefront and lobby entrance frontages.
 - e). The finished ceiling of an arcade interior may be arched or flat, but must have a greater CLEARANCE than the openings between columns OR PIERS.

4. MID-RISE DISTRICTS

Mid-Rise 5 (MR5)

i. Stoop

- i. A stoop is a front, side, or rear facing set of stairs with a landing providing access to a ground story or basement entrance of a building.

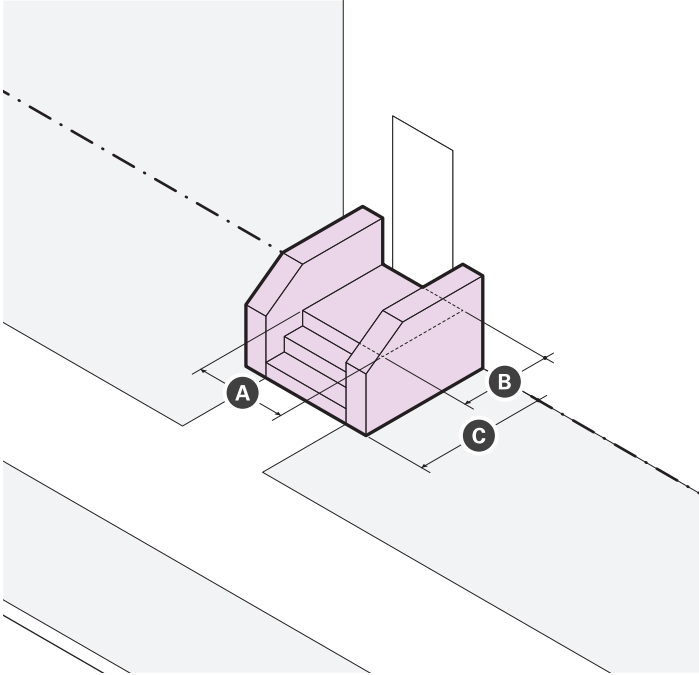

Dimensions	
A Landing Width (min)	4 ft
B Landing Projection (min)	4 ft
C Setback Encroachment (max)	=
Front	100%
Side & Rear	0 ft

- ii. Standards
 - a). Stairs may be recessed into the building facade when the building is set back four (4) feet or less.
 - b). Stairs are not permitted to encroach onto any abutting sidewalk.

j. Bay Window

- i. A bay window is an assembly of windows projecting from a building to provide additional HABITABLE space, increased light, multi-directional views, and ARTICULATION to an exterior wall.

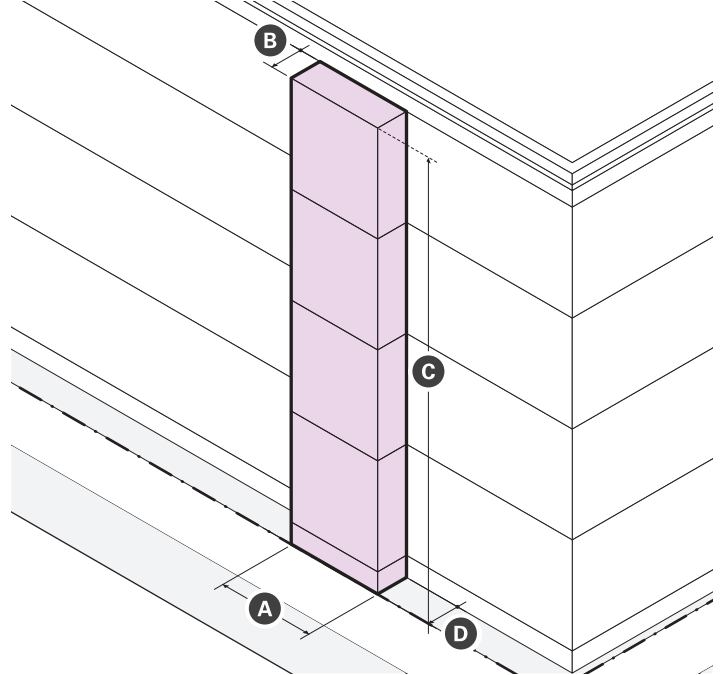

Dimensions	
A Width (max)	16 ft
B Projection (max)	3 ft
C Height (max)	Height of BUILDING in Stories
D Setback Encroachment (max)	=
Front	3 ft
Side	0 ft
Rear	0 ft
Fenestration (min)	60%

- ii. Standards
 - a). Bay windows, including box and bow windows, must include at least three (3) windows for each story of the bay window.
 - b). The cumulative width of multiple bays may equal up to fifty percent (50%) of the width of the exterior wall from which the bays project.
 - c). Bays projecting over the sidewalk of a public THOROUGHFARE must have at least two (2) stories of CLEARANCE and be compliant with all City Ordinances.
 - d). Bay windows may have integrated recessed balconies, terraces, or roof decks.

k. Balcony

- i. A balcony is a front, side, or rear facing upper story platform with a railing accessed from an entrance of a building and providing outdoor AMENITY SPACE.

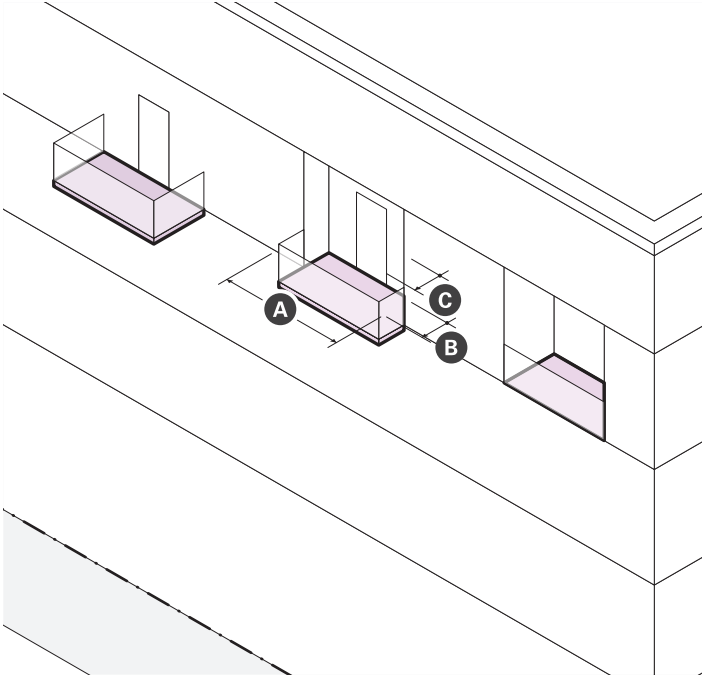

Dimensions	
A Width (min)	5 ft
B Depth (max)	5 ft
D Area (min)	50 sf
Clearance (min)	10 ft
Permitted Front SETBACK ENCROACHMENT (max)	6 ft

- ii. Standards
 - a). Balconies may be recessed, projecting, a combination of the two, or terraced as part of the roof of a portico, porch, or bay.
 - b). A balcony that projects over the sidewalk of a public THOROUGHFARE requires compliance with all City Ordinances.
 - c). The guard rail of any balcony oriented toward a FRONT LOT LINE must permit visual supervision of the PUBLIC REALM through the posts and rails.
 - d). The guard rail of any balcony oriented toward a side OF REAR LOT LINE ABUTTING the NR district must include sight-obscuring visual screening so that it is at least fifty percent (50%) opaque.

l. Arcade

- i. An arcade is a pedestrian walkway covered by the upper floors of a building. The GROUND STORY FACADE is SETBACK and upper floors are supported by a colonnade or supports.

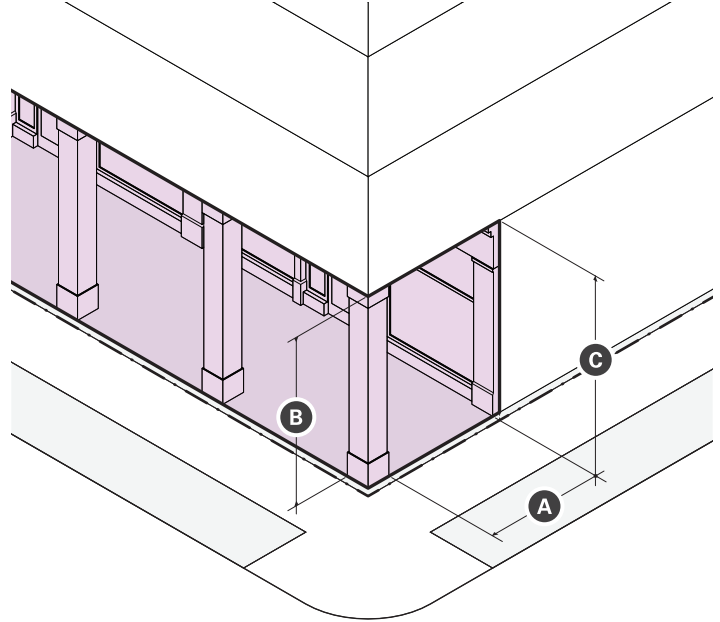

Dimensions		
A Depth (min/max)	10 ft	15 ft
B Height (max)	1 STORY	
C Clearance (min/max)	14 ft	24 ft

- ii. Standards
 - a). Arcades must extend the entire width of a building and must have a consistent depth.
 - b). Support columns or PIERS may be spaced no farther apart than they are tall.
 - c). Arcades are considered part of the building for the purpose of measuring FACADE build out.
 - d). Arcades may be combined only with storefront and lobby entrance frontages.
 - e). The finished ceiling of an arcade interior may be arched or flat, but must have a greater CLEARANCE than the openings between columns OR PIERS.

4. MID-RISE DISTRICTS

Mid-Rise 6 (MR6)

i. Stoop

- i. A stoop is a front, side, or rear facing set of stairs with a landing providing access to a ground story or basement entrance of a building.

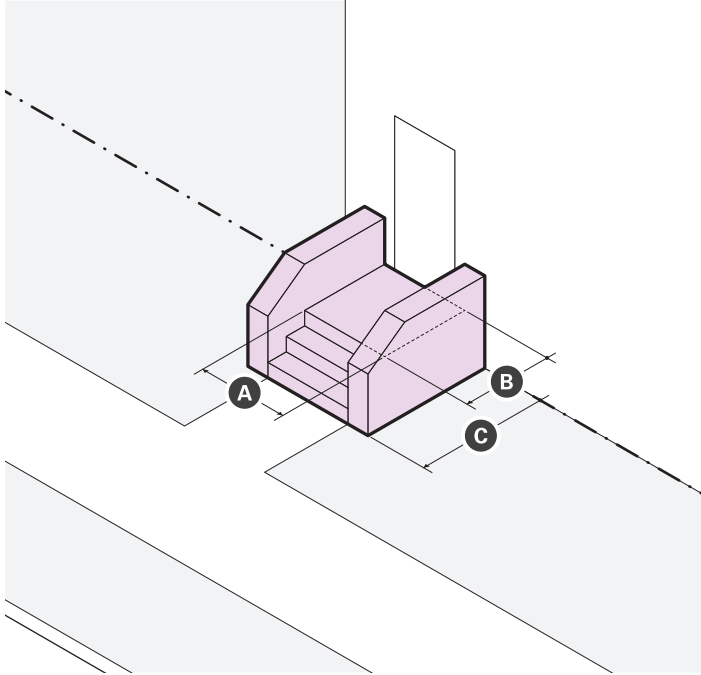

Dimensions	
A Landing Width (min)	4 ft
B Landing Projection (min)	4 ft
C Setback Encroachment (max)	=
Front	100%
Side & Rear	0 ft

- ii. Standards
 - a). Stairs may be recessed into the building facade when the building is set back four (4) feet or less.
 - b). Stairs are not permitted to encroach onto any abutting sidewalk.

j. Bay Window

- i. A bay window is an assembly of windows projecting from a building to provide additional HABITABLE space, increased light, multi-directional views, and ARTICULATION to an exterior wall.

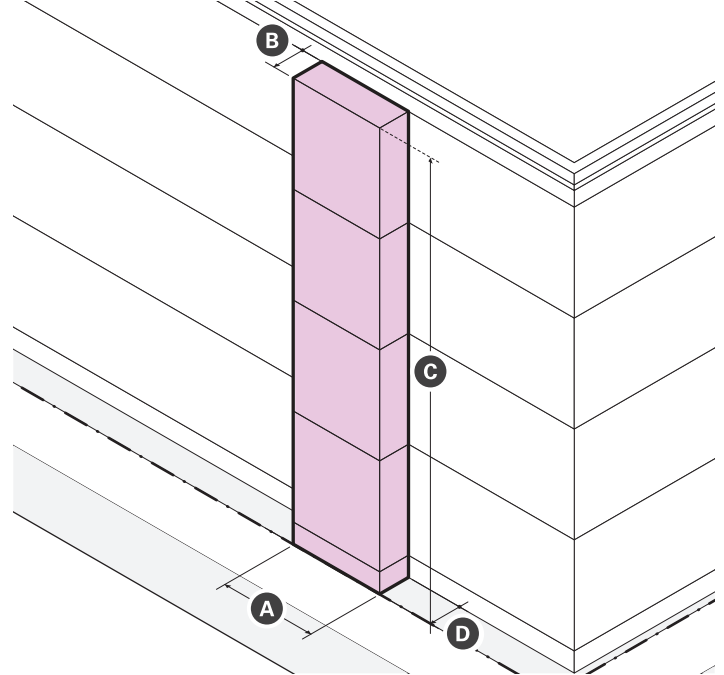

Dimensions	
A Width (max)	16 ft
B Projection (max)	3 ft
C Height (max)	Height of BUILDING in Stories
D Setback Encroachment (max)	=
Front	3 ft
Side	0 ft
Rear	0 ft
Fenestration (min)	60%

- ii. Standards
 - a). Bay windows, including box and bow windows, must include at least three (3) windows for each story of the bay window.
 - b). The cumulative width of multiple bays may equal up to fifty percent (50%) of the width of the exterior wall from which the bays project.
 - c). Bays projecting over the sidewalk of a public THOROUGHFARE must have at least two (2) stories of CLEARANCE and be compliant with all City Ordinances.
 - d). Bay windows may have integrated recessed balconies, terraces, or roof decks.

k. Balcony

- i. A balcony is a front, side, or rear facing upper story platform with a railing accessed from an entrance of a building and providing outdoor AMENITY SPACE.

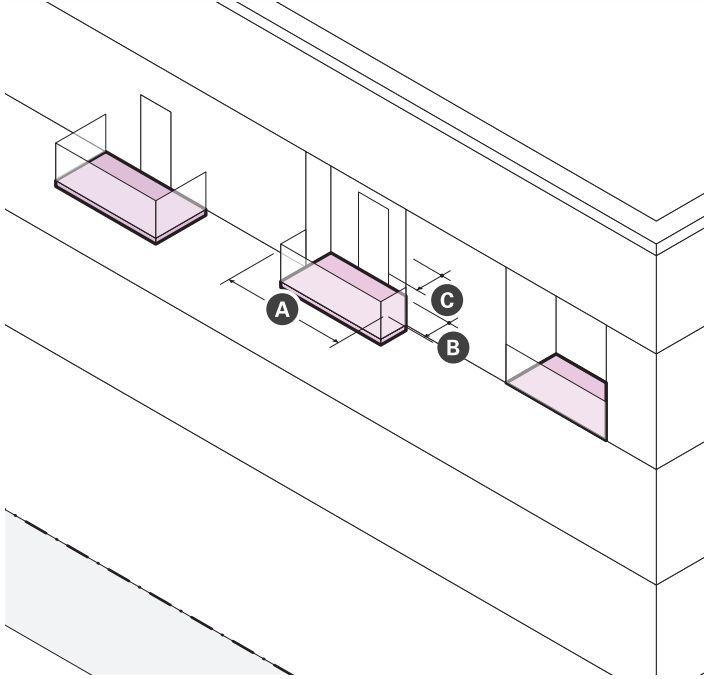

Dimensions	
A Width (min)	5 ft
B Depth (max)	5 ft
D Area (min)	50 sf
Clearance (min)	10-ft
Permitted Front SETBACK ENCROACHMENT (max)	6 ft

- ii. Standards
 - a). Balconies may be recessed, projecting, a combination of the two, or terraced as part of the roof of a portico, porch, or bay.
 - b). A balcony that projects over the sidewalk of a public THOROUGHFARE requires compliance with all City Ordinances.
 - c). The guard rail of any balcony oriented toward a FRONT LOT LINE must permit visual supervision of the PUBLIC REALM through the posts and rails.
 - d). The guard rail of any balcony oriented toward a side OF REAR LOT LINE ABUTTING the NR district must include sight-obscuring visual screening so that it is at least fifty percent (50%) opaque.

l. Arcade

- i. An arcade is a pedestrian walkway covered by the upper floors of a building. The GROUND STORY FACADE is SETBACK and upper floors are supported by a colonnade or supports.

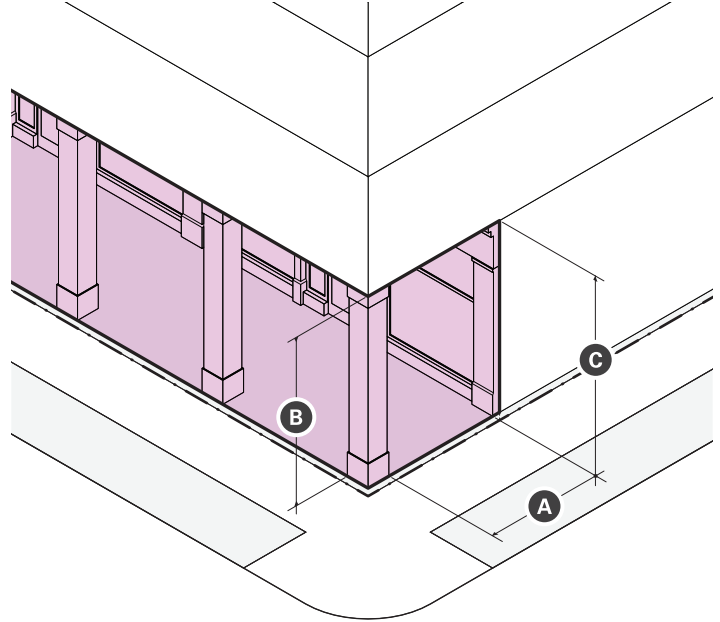

Dimensions		
A Depth (min/max)	10 ft	15 ft
B Height (max)	1 STORY	
C Clearance (min/max)	14 ft	24 ft

- ii. Standards
 - a). Arcades must extend the entire width of a building and must have a consistent depth.
 - b). Support columns or PIERS may be spaced no farther apart than they are tall.
 - c). Arcades are considered part of the building for the purpose of measuring FACADE build out.
 - d). Arcades may be combined only with storefront and lobby entrance frontages.
 - e). The finished ceiling of an arcade interior may be arched or flat, but must have a greater CLEARANCE than the openings between columns OR PIERS.

5 HIGH-RISE DISTRICTS

HIGH-RISE



5. HIGH-RISE DISTRICTS

High-Rise (HR)

i. Stoop

- i. A stoop is a front, side, or rear facing set of stairs with a landing providing access to a ground story or basement entrance of a building.

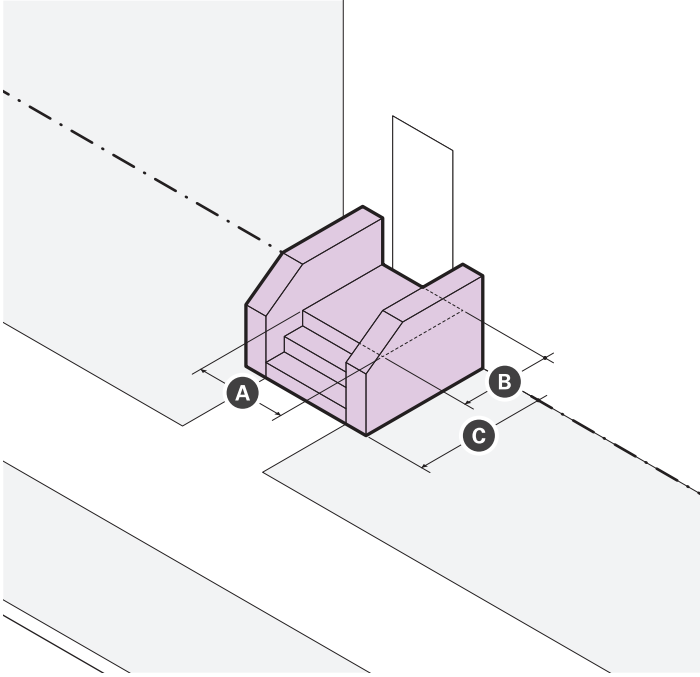

Dimensions	
A Landing Width (min)	4 ft
B Landing Projection (min)	4 ft
C Setback Encroachment (max)	=
Front	100%
Side & Rear	0 ft

- ii. Standards
 - a). Stairs may be recessed into the building facade when the building is set back four (4) feet or less.
 - b). Stairs are not permitted to encroach onto any abutting sidewalk.

j. Bay Window

- i. A bay window is an assembly of windows projecting from a building to provide additional HABITABLE space, increased light, multi-directional views, and ARTICULATION to an exterior wall.

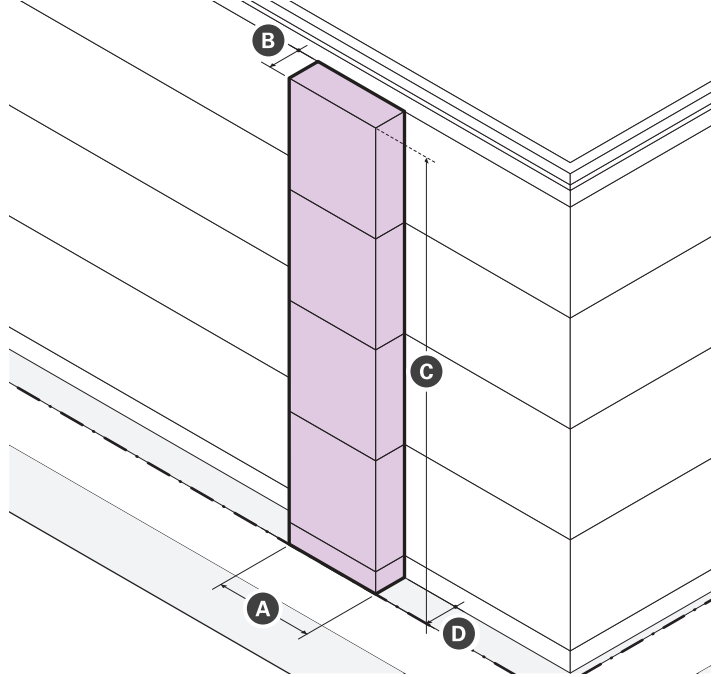

Dimensions	
A Width (max)	16 ft
B Projection (max)	3 ft
C Height (max)	Height of BUILDING in Stories
D Setback Encroachment (max)	=
Front	3 ft
Side	0 ft
Rear	0 ft
Fenestration (min)	60%

- ii. Standards
 - a). Bay windows, including box and bow windows, must include at least three (3) windows for each story of the bay window.
 - b). The cumulative width of multiple bays may equal up to fifty percent (50%) of the width of the exterior wall from which the bays project.
 - c). Bays projecting over the sidewalk of a public THOROUGHFARE must have at least two (2) stories of CLEARANCE and be compliant with all City Ordinances.
 - d). Bay windows may have integrated recessed balconies, terraces, or roof decks.

k. Balcony

- i. A balcony is a front, side, or rear facing upper story platform with a railing accessed from an entrance of a building and providing outdoor AMENITY SPACE.

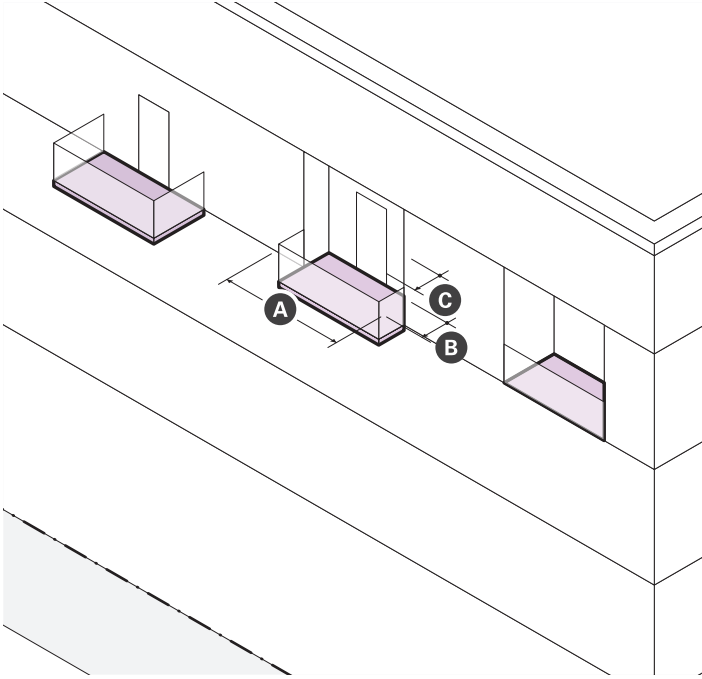

Dimensions	
A Width (min)	5 ft
B Depth (max)	5 ft
D Area (min)	50 sf
Clearance (min)	10 ft
Permitted Front SETBACK ENCROACHMENT (max)	6 ft

- ii. Standards
 - a). Balconies may be recessed, projecting, a combination of the two, or terraced as part of the roof of a portico, porch, or bay.
 - b). A balcony that projects over the sidewalk of a public THOROUGHFARE requires compliance with all City Ordinances.
 - c). The guard rail of any balcony oriented toward a FRONT LOT LINE must permit visual supervision of the PUBLIC REALM through the posts and rails.
 - d). The guard rail of any balcony oriented toward a side OF REAR LOT LINE ABUTTING the NR district must include sight-obscuring visual screening so that it is at least fifty percent (50%) opaque.

l. Arcade

- i. An arcade is a pedestrian walkway covered by the upper floors of a building. The GROUND STORY FACADE is SETBACK and upper floors are supported by a colonnade or supports.

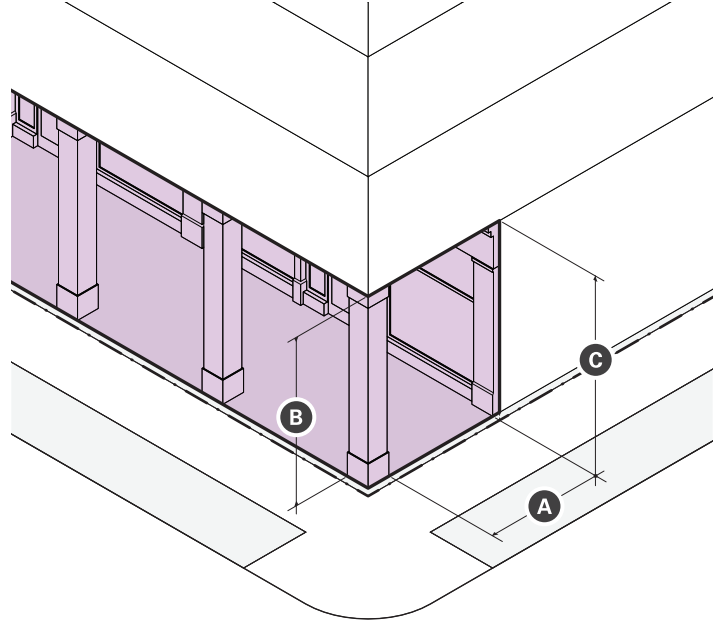

Dimensions		
A Depth (min/max)	10 ft	15 ft
B Height (max)	2 stories	
C Clearance (min/max)	14 ft	24 ft

- ii. Standards
 - a). Arcades must extend the entire width of a building and must have a consistent depth.
 - b). Support columns or PIERS may be spaced no farther apart than they are tall.
 - c). Arcades are considered part of the building for the purpose of measuring FACADE build out.
 - d). Arcades may be combined only with storefront and lobby entrance frontages.
 - e). The finished ceiling of an arcade interior may be arched or flat, but must have a greater CLEARANCE than the openings between columns OR PIERS.

6.0 COMMERCIAL DISTRICTS

6.0 COMMERCIAL DISTRICTS

Fabrication (FAB)

i. Bay Window

- i. A bay window is an assembly of windows projecting from a building to provide additional HABITABLE space, increased light, multi-directional views, and ARTICULATION to an exterior wall.

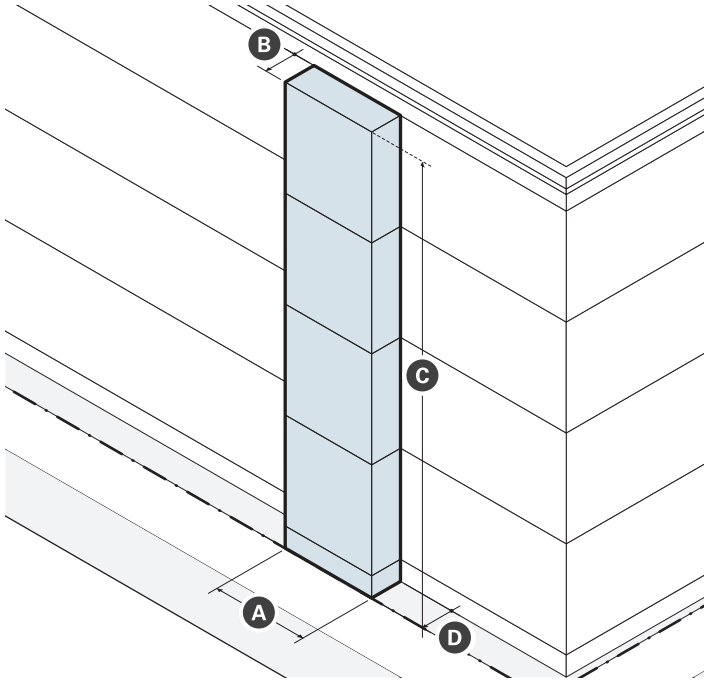

Dimensions	
A Width (max)	16 ft
B Projection (max)	3 ft
C Height (max)	Height of BUILDING in Stories
D <u>Setback Encroachment (max)</u>	=
<u>Front</u>	<u>3 ft</u>
<u>Side</u>	<u>0 ft</u>
<u>Rear</u>	<u>0 ft</u>
Fenestration (min)	60%

- ii. Standards
 - a). Bay windows, including box and bow windows, must include at least three (3) windows for each story of the bay window.
 - b). The cumulative width of multiple bays may equal up to fifty percent (50%) of the width of the exterior wall from which the bays project.
 - c). Bays projecting over the sidewalk of a public THOROUGHFARE must have at least two (2) stories of CLEARANCE and be compliant with all City Ordinances.
 - d). Bay windows may have integrated recessed balconies, terraces, or roof decks.

j. Arcade

- i. An arcade is a frontage type featuring a pedestrian walkway covered by the upper floors of a BUILDING. The GROUND STORY FACADE IS SETBACK and upper floors are supported by a colonnade or supports.

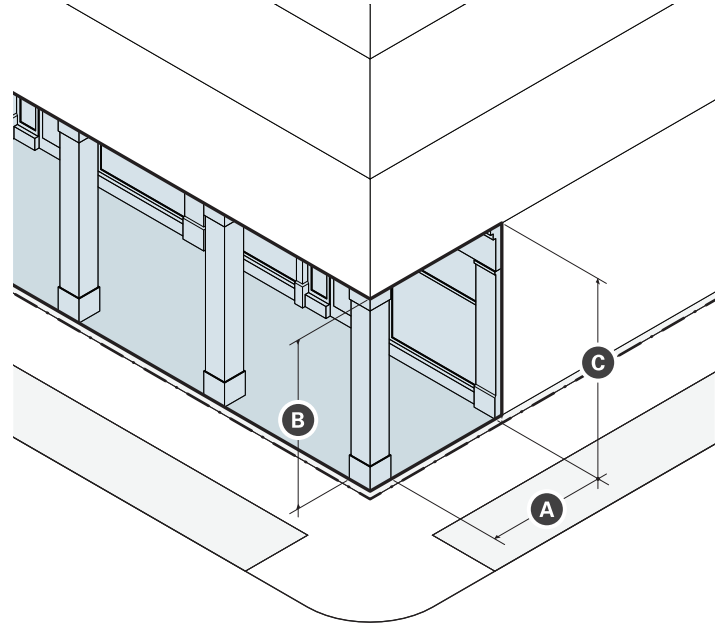

Dimensions		
A Depth (min/max)	10 ft	15 ft
B Height (max)	1 STORY	
C <u>Clearance (min/max)</u>	<u>14 ft</u>	<u>24 ft</u>

- ii. Standards
 - a). Arcades must extend the entire width of a BUILDING and must have a consistent depth.
 - b). Support columns or PIERS may be spaced no farther apart than they are tall.
 - c). Arcades are considered part of the BUILDING for the purpose of measuring FACADE build out.
 - d). Arcades may be combined only with storefront and lobby entrance frontages
 - e). The finished ceiling of an arcade interior may be arched or flat, but must have a greater CLEARANCE than the openings between columns OR PIERS.

6.0 COMMERCIAL DISTRICTS

Commercial Core (CC)

i. Bay Window

- i. A bay window is an assembly of windows projecting from a building to provide additional HABITABLE space, increased light, multi-directional views, and ARTICULATION to an exterior wall.

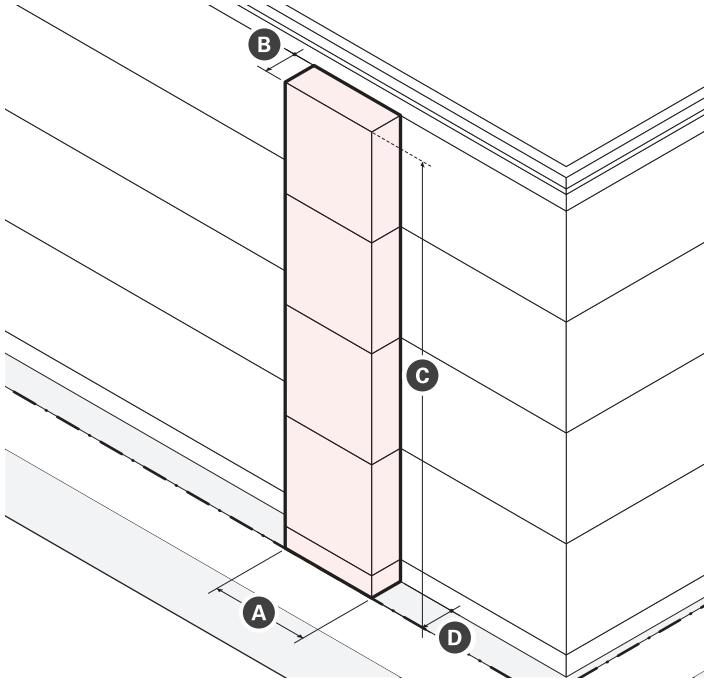

Dimensions	
A Width (max)	16 ft
B Projection (max)	3 ft
C Height (max)	Height of BUILDING in Stories
D <u>Setback Encroachment (max)</u>	=
<u>Front</u>	<u>3 ft</u>
<u>Side</u>	<u>0 ft</u>
<u>Rear</u>	<u>0 ft</u>
<u>Fenestration (min)</u>	<u>60%</u>

- ii. Standards
 - a). Bay windows, including box and bow windows, must include at least three (3) windows for each story of the bay window.
 - b). The cumulative width of multiple bays may equal up to fifty percent (50%) of the width of the exterior wall from which the bays project.
 - c). Bays projecting over the sidewalk of a public THOROUGHFARE must have at least two (2) stories of CLEARANCE and be compliant with all City Ordinances.
 - d). Bay windows may have integrated recessed balconies, terraces, or roof decks.

j. Arcade

- i. An arcade is a frontage type featuring a pedestrian walkway covered by the upper floors of a BUILDING. The GROUND STORY FACADE IS SETBACK and upper floors are supported by a colonnade or supports.

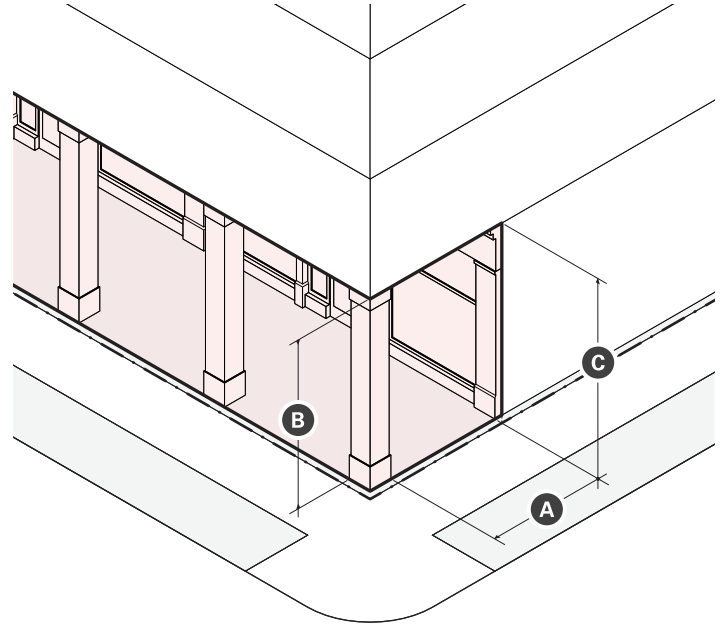

Dimensions		
A Depth (min/max)	10 ft	15 ft
B Height (max)	--	
<u>1 - 6 Story Building</u>	<u>1 Story</u>	
<u>7+ Story Building</u>	<u>2 Stories</u>	
C <u>Clearance (min/max)</u>	<u>14 ft</u>	<u>24 ft</u>

- ii. Standards
 - a). Arcades must extend the entire width of a BUILDING and must have a consistent depth.
 - b). Support columns or PIERS may be spaced no farther apart than they are tall.
 - c). Arcades are considered part of the BUILDING for the purpose of measuring FACADE build out.
 - d). Arcades may be combined only with storefront and lobby entrance frontages
 - e). The finished ceiling of an arcade interior may be arched or flat, but must have a greater CLEARANCE than the openings between columns OR PIERS.

6.0 COMMERCIAL DISTRICTS

Commercial Business (CB)

i. Arcade

- i. An arcade is a frontage type featuring a pedestrian walkway covered by the upper floors of a BUILDING. The GROUND STORY FACADE IS SETBACK and upper floors are supported by a colonnade or supports.

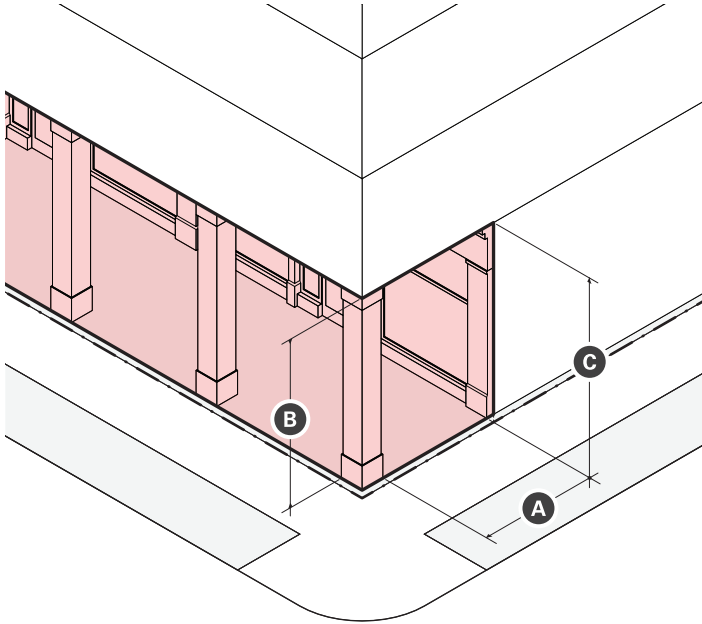

Dimensions		
A Depth (min/max)	10 ft	15 ft
B Height (max)	1 STORY	
C Clearance (min/max)	14 ft	24 ft

- ii. Standards
 - a). Arcades must extend the entire width of a BUILDING and must have a consistent depth.
 - b). Support columns or PIERS may be spaced no farther apart than they are tall.
 - c). Arcades are considered part of the BUILDING for the purpose of measuring FACADE build out.
 - d). Arcades may be combined only with storefront and lobby entrance frontages
 - e). The finished ceiling of an arcade interior may be arched or flat, but must have a greater CLEARANCE than the openings between columns OR PIERS.