

Legalizing Mid-Rise Single-Stair Housing in Massachusetts

A Report on the Impact of Allowing Mid-Rise
Point Access Blocks on Housing Design and
Development in Greater Boston and Beyond

October 2024



B O S T O N
I N D I C A T O R S



utile

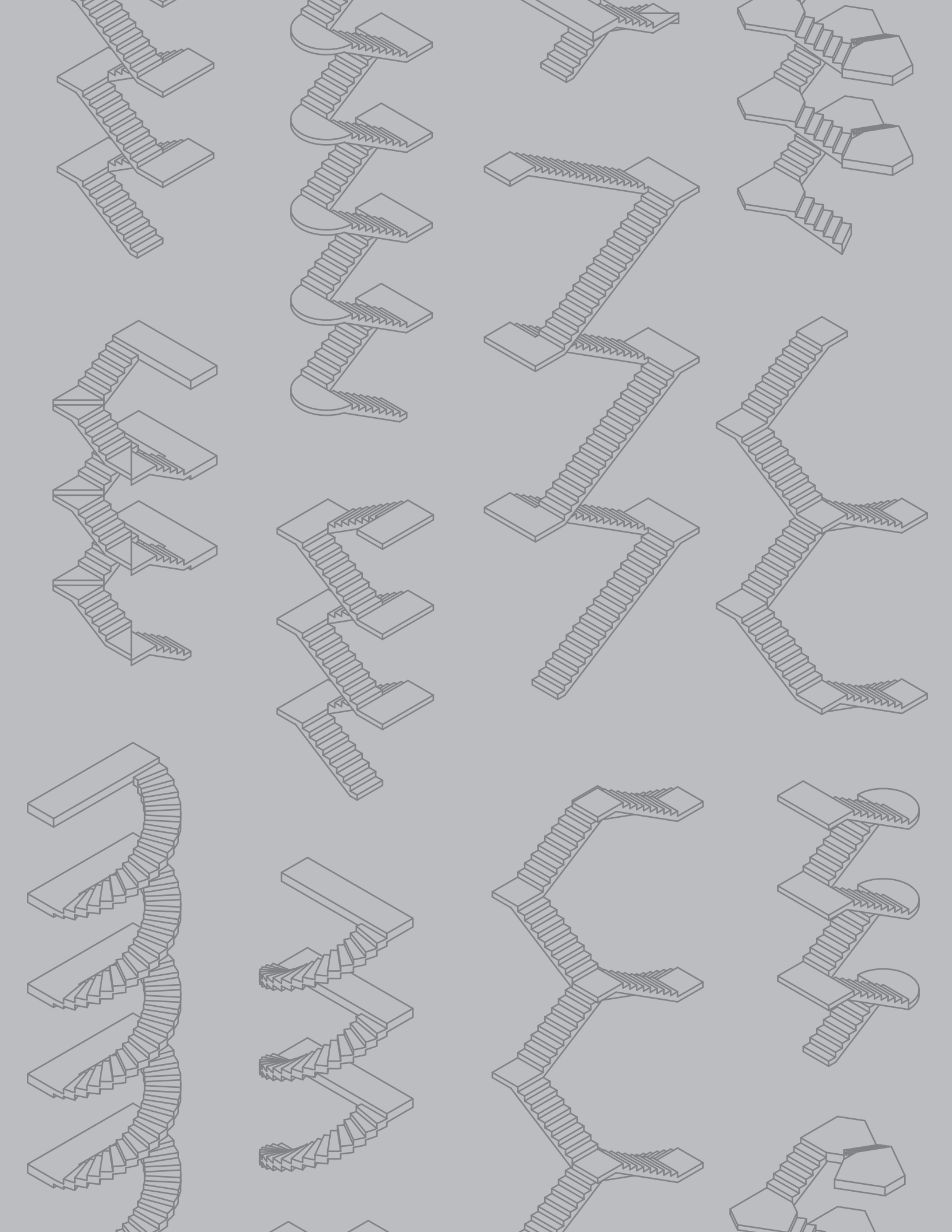

Legalizing Mid-Rise Single-Stair Housing
in Massachusetts

A Report on the Impact of Allowing Mid-
Rise Point Access Blocks on Housing
Design and Development in Greater Boston
and Beyond

October 2024

Foreword by
Luc Schuster, Boston Indicators

Report by Utile
Sam Naylor
Tim Love
Simona Rodriguez Villand
Camille Wimpe
Kyle Jonasen
Aaron Smithson
Lilly Saniel-Banrey
Maria Ferreria

Editorial Advising by The Joint Center for
Housing Studies of Harvard University

Chris Herbert
Carlos Martín
Alexander Hermann
David Luberoff

Consulting, Advice, and Support from

AIA Massachusetts
Boston Society for Architecture
Code Red Consulting
Conrad Speckert, LGA Architectural Partners
Eduardo Mendoza, Livable Communities
Initiative
Michael Eliason, Larch Lab
Sean Jursnick, SAR+ Architects
Stephen Smith, Center for Building in North
America

©2024 President and Fellows of Harvard College.
Any opinions expressed in this report are those
of the author(s) and not those of the Joint Center
for Housing Studies of Harvard University,
Boston Indicators, or of any of the persons
or organizations providing support to these
organizations. This report was made possible
with funding from Boston Indicators, the research
center at the Boston Foundation.

The material provided in this report is for
informational purposes only. The authors,
funders, and other contributors assume no
liability for any damage, injury, loss, or expense
that may be incurred or suffered as a result of the
use of this report, including products, building
techniques, or practices. Drawings and diagrams
of projects have been made with every effort
to illustrate the work accurately. The editors
apologize for any errors or misrepresentations.

B O S T O N
INDICATORS

Boston Indicators is the research center at the Boston Foundation, which works to advance a thriving Greater Boston for all residents across all neighborhoods. We do this by analyzing key indicators of well-being and by researching promising ideas for making our region more prosperous, equitable and just. To ensure that our work informs active efforts to improve our city, we work in partnership with community groups, civic leaders, and Boston's civic data community to produce special reports and host public convenings.

bostonindicators.org



The Harvard Joint Center for Housing Studies strives to improve equitable access to decent, affordable homes in thriving communities. We conduct rigorous research to advance policy and practice, and we bring together diverse stakeholders to spark new ideas for addressing housing challenges. Through teaching and fellowships, we mentor and inspire the next generation of housing leaders.

jchs.harvard.edu

utile

Utile is a Boston-based design firm built like a think tank. We thrive on solving complex problems in intelligent and pragmatic ways. From theoretical issues that frame policy to the practical implementation of architectural commissions, Utile develops a rigorous research-based approach for finding the best solutions.

utiledesign.com

CONTENTS

	Foreword	5
<hr/>		
I.	Status Quo vs. Single-Stair	6
	Podium Production	6
	Point Access Blocks	8
	Quality of Life	10
	Unlocking Density	14
<hr/>		
II.	Greater Boston Housing History	16
	Resilient Residential Types	16
	An evolving Building Code	18
	Single Stair Today	20
<hr/>		
III.	Egress Code Landscape	22
	The North American Outlier	22
	A Changing Landscape	25
	The Proposal	27
	Related Building Code Provisions	
	Worth Reconsideration	28
<hr/>		
IV.	Point Loaded Potentials	30
	Building More Mid-rise	30
	PABs for Small Plots	30
	Homes We Can be Proud of	32
	Citations	36
	Terms	37
	Resources	38

FOREWORD

We talk often about Greater Boston’s housing situation as a crisis. The better description is that it’s become chronically ill. But not terminally. We need to bring to bear all the remedies we can to treat the mix of symptoms that deprive our housing market—and by extension, our communities—of full health.

Full health would be having an abundant offering of diverse housing types so that families at different stages of life can find suitable housing. Instead, we have:

- Underproduction compared to high demand for people to live and work in the area
- Rising home prices and rents
- Lack of diversity in housing types, without enough lower-cost options, especially in walkable, transit-proximate urban areas
- Insufficient family-sized units in high-demand areas
- Sprawling development patterns, which isn’t good for environmental sustainability or for quality of life
- Apartment complexes with restricted layouts that often lack community-enhancing common spaces

Boston Indicators (and many, many others) has been exploring the role of zoning restrictions in contributing to this housing market dysfunction through research projects like *Zoned Out* and *Exclusionary by Design*. And the state government is starting to act in a new way, as evidenced by

2021’s MBTA Communities law and the recent statewide legalization of Accessory Dwelling Units in the Affordable Homes Act. But there’s a growing recognition that zoning reform alone won’t cure all our housing ills. It can certainly create an onramp for more, and better, housing construction. But it’s clear we need to work on other fronts as well. So, with this report, we begin an exploration of other barriers to creating the abundant, diverse, affordable housing that we all deserve. Looming large among them is the building code. It is an amalgam of regulations that should evolve with time and technology. But old concerns and considerations live on in the building code long after technological or architectural advances have overridden their safety value. For example, the use of engineered wood is often limited or prohibited in buildings of a certain height, even though other countries have proven its flexibility to achieve the same fire ratings as concrete or steel with far less weight and carbon footprint. Regulations requiring unnecessarily large and expensive elevators are another area starting to get scrutiny.

But here we start by diving into staircases and the common building code requirement that projects between three and six stories include two separate means of egress (i.e., staircases). As the fire safety that redundant staircases provide has become more than matched by advances in materials, smoke detection, and sprinkler systems, we’ve seen growing momentum across North America to reconsider this requirement. So, in this report we explore the

reasons for, and potential impact of changing this requirement in Massachusetts. Such a shift might allow a huge jump in unit design flexibility. It’s especially relevant in Greater Boston as housing advocates are working to direct housing production into dense walkable neighborhoods near transit. These areas tend to be more built-out and parcels are typically smaller. So, allowing for single-stair construction unlocks these parcels for developments that fit their scale, and pencil out—potentially doubling the number of units permissible.

We could have no better partners in this work than Harvard’s Joint Center for Housing Studies and Utile Design—the former a leading national think tank on all things housing, and the latter an innovative architectural and planning firm that blends design capability with broader policy and planning expertise. Their skills combined made this unique report possible, creating a primer for the growing conversation around revising the building code in Massachusetts. While it doesn’t address every detail that will inevitably emerge, we hope it’s a useful starting point for discussions around balancing safety concerns with the urgent need to allow for the construction of more flexible, affordable housing in Massachusetts.

—Luc Schuster, Boston Indicators

I. Status Quo vs. Single-Stair

PODIUM PRODUCTION

Building codes, as much as municipal-level zoning codes, affect the geographic distribution, physical characteristics, and market dynamics of housing production. Yet, because knowledge of building codes is the purview of architects and builders and not economists or policymakers, the impact of building codes is underappreciated in the housing policy or planning world. Similarly, because knowledge of the building code's impacts on development and design is only gained by spending years in practice, their significance for architectural design is under considered as a real area of innovation in design schools. One pernicious example is the double-loaded podium building, which has arisen from the intersection of egress codes, construction types, and market logics, creating a housing type that has been much-maligned in the media, and yet continues to be the dominant multifamily typology across much of the US.

A podium building—sometimes referred to as a five-over-one because it often consists of five wood-framed stories built atop a “podium” of one story of concrete or steel—can maximize value in two ways. The first is the way these buildings push density to the maximum just below the high-rise building code threshold, often demarcated as the point at which fire rescue service ladders from the ground can no longer reach the highest occupiable window. (This is defined in the International Building Code (IBC) as 75 feet above grade plane, but in Massachusetts has been amended to be 70 feet.) This is important because the structural framing that can be

Double-Loaded Podium Building

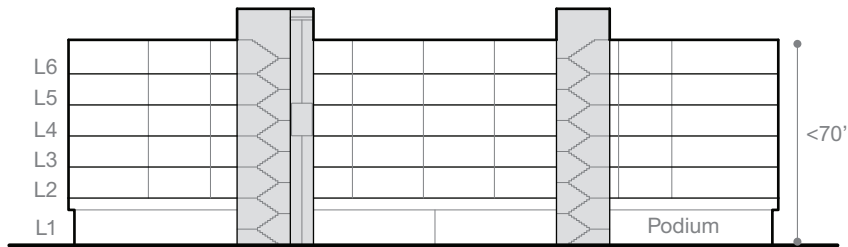

Building Section

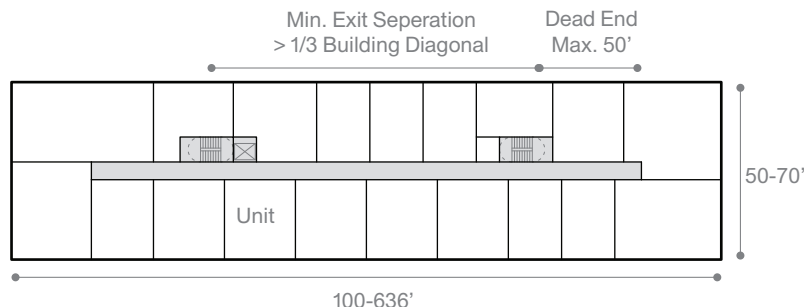

Typical Floor Plan

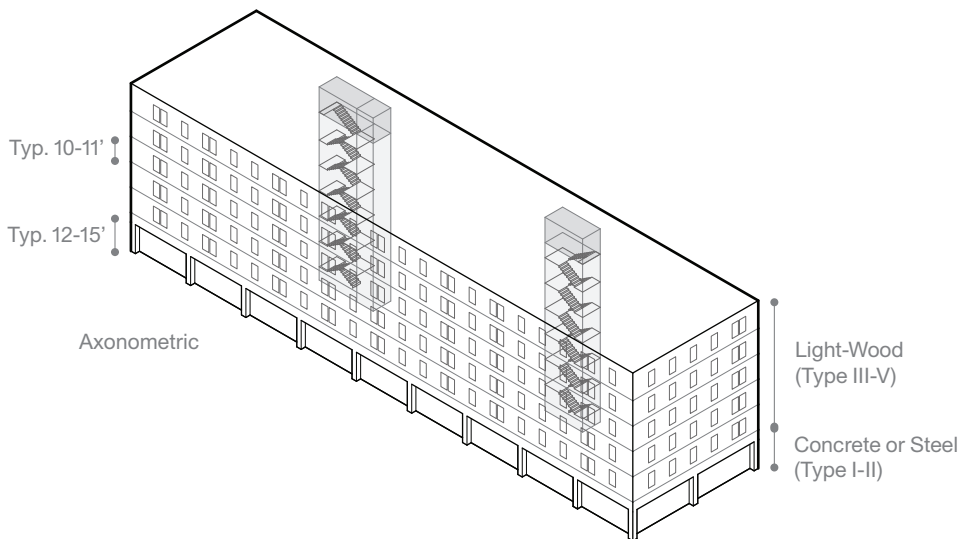

Axonometric

used for non-high-rise buildings, which includes light wood frame and lightweight steel construction, is much less expensive than the noncombustible steel frame or cast-in-place concrete structural solutions required by the high-rise code. Other secondary life safety requirements kick in too, that in aggregate with the added costs of the structural frame can add between 15% and 25% to the cost of the project on a per square foot basis.¹

If these parameters explain the height of cost effective multifamily buildings, the cost of vertical circulation (stairs and elevators) helps explain the size of typical five-over-one buildings in plan. In North America, a typical multifamily building has two fire stairs and one or two elevators (depending on the size of the building and the specific market conditions). Since most buildings are required to have two stairs connected by a smoke-proof and fire-rated corridor, developers are incentivised to stretch the floor plan of said building to maximize the number of units on either side of the hallway (or a so-called double-loaded corridor) while remaining within the limitations for travel distances from the furthest point in the most remote unit from an exit. Put another way, real estate developers prefer project opportunities where they can harvest as much net rentable or sellable residential area as possible from an investment in two stairs and two elevators. This is called building efficiency (net area divided by gross area), and usually calculated as a percentage figure, ranging from 75% to 90% in multifamily structures. This translates to typical residential floor plates that need to be at least 14,000 gross

square feet to meet financing underwriting requirements in most North American markets. In locating these projects, sites are primarily chosen by how best a double-loaded podium building can be fit within it, or stretched to fill its volume. Not only is this the most efficient building to produce under the confluence of our codes and construction types, but it's also always more efficient to build one large building than two smaller ones as the latter would duplicate the required number of stairs, and greatly expand the building services and exterior wall area, limiting efficiency. Because of this, and because developments are naturally more profitable as

they grow (any building above a handful of units requires the same consultants, code complexities, and construction sophistication as a building with hundreds of units), the logic of the podium building then is also baked into higher land prices, regardless of present zoning requirements. Thus sites that are too small for these building types are either combined into a larger parcel, or lay underdeveloped. When combined with the rationale for building heights described above and other factors, the six (or seven in some cases) story I-, H-, L- and C-shaped double-loaded podium building is both justified and elevated as a model to emulate, without equal.

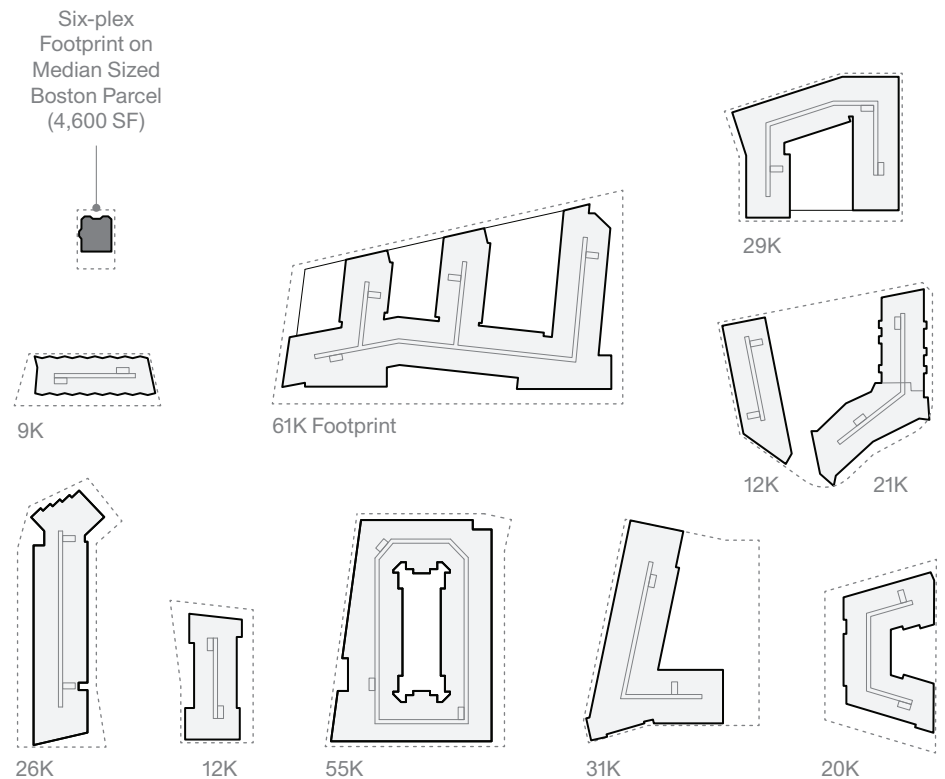

POINT ACCESS BLOCKS

The primary reason behind the ubiquity of podium buildings is the requirement for two means of egress (stairs) for any building above 12 units (in Massachusetts). This limitation arose in the mid-20th century in North America, but it is not common worldwide. Data shows that advances in construction technology, both passive and active, and other life safety provisions make the two-stairway requirement antiquated, and unreasonable for small mid-rise buildings that can offer equal or greater life safety provisions within an architectural typology that offers more efficiency, daylight, ventilation, and variations in density.

Single-stair residential buildings, or what are commonly referred to as Point Access Blocks (PABs), compose a collection of building types where, in lieu of a corridor loaded on both sides with units, units radiate from a single central vertical circulation core. With only one stair access point there is no need for a long, dimly lit interior hallway, and thus more floor space can be dedicated to units, and those units can be more flexible in shape, size, and location. This type can also be ganged together to create larger complexes, ones that offer similar efficiencies in plan but far superior quality of light and air for the residents. In Boston and across North American cities that expanded in the mid-20th century there is a history of PABs, often modeled after international precedents at the time. Today, across the world, the dominant form of multifamily housing continues to be the PAB, except for North America.

Small Infill

Capitol Core
Seattle, WA
2017
17 Units
76% Efficient
1,374 GSF Floor Plate

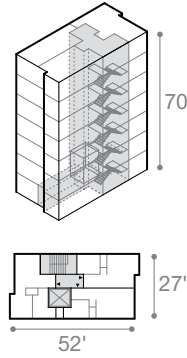

Apartment in Katayama
Suita-Shi, Japan
2007
10 Units
66% Efficient
970 GSF FP

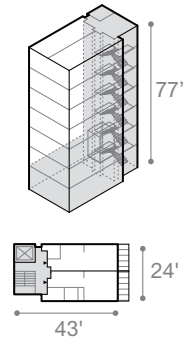

Party Wall

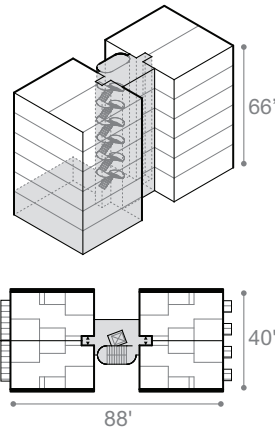

17 Apartments
Paris, France
2017
17 Units
84% Efficient
+/- 2,300 GSF FP

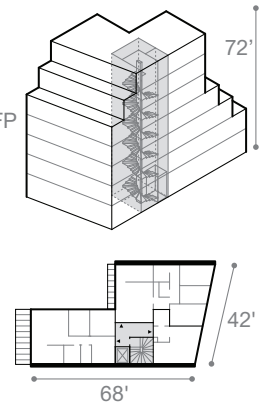

Side / Single-Loaded

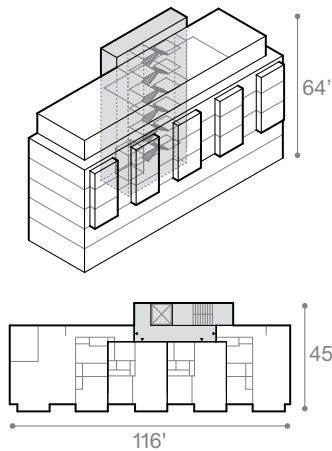

High Street Apartments
Thornbury, Australia
2022
13 Units
83% Efficient
2,225 GSF FP

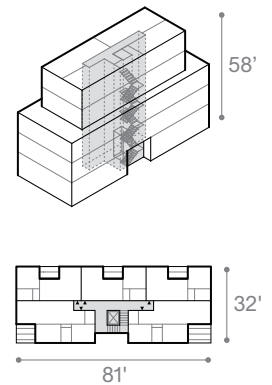

Center Core

Quartier am Seebogen
Vienna, Austria
2021
49 Units
83% Efficient
5,713 GSF FP

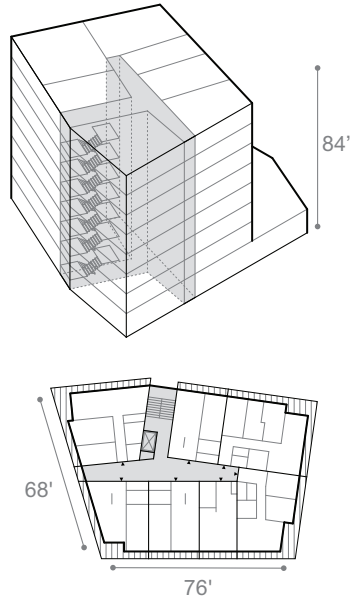

Suurstoffi Development
Zurich, Switzerland
2015
16 Units
90% Efficient
3,455 GSF FP

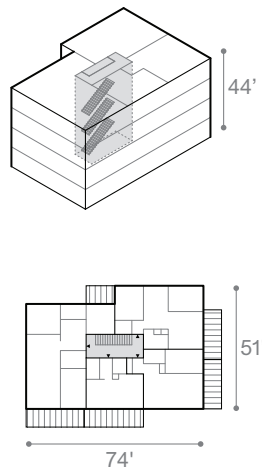

Apartments in Wetzikon
Wetzikon, Switzerland
2021
12 Units
89% Efficient
2,891 GSF FP

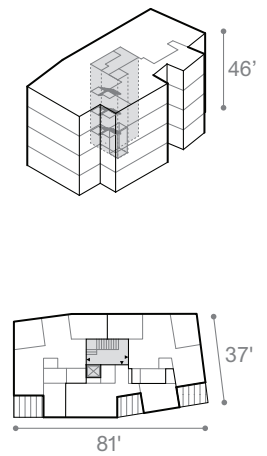

Blocks

Fittjahojden
Stockholm, Sweden
2019
24 Units per core
88% Efficient
3,480 GSF FP

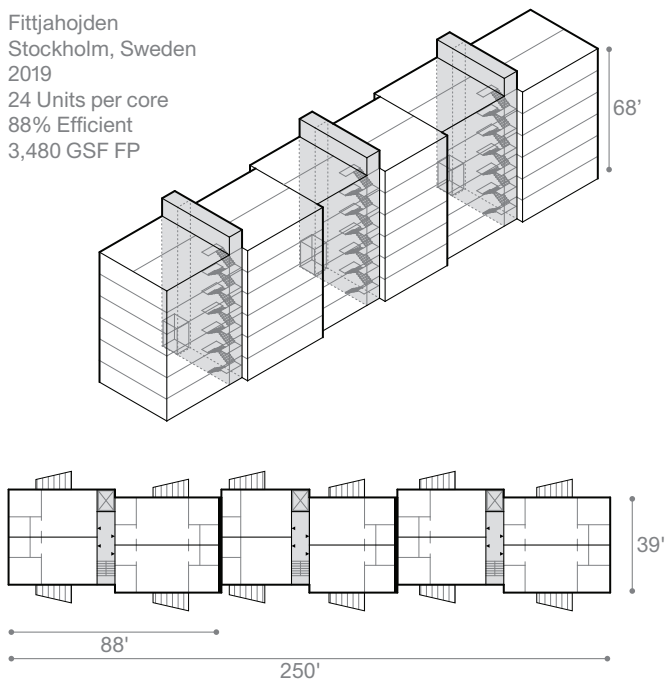

Dennewitz Eins
Berlin, Germany
2013
12-18 Units per core
88% Efficient
+/- 4,070 GSF FP

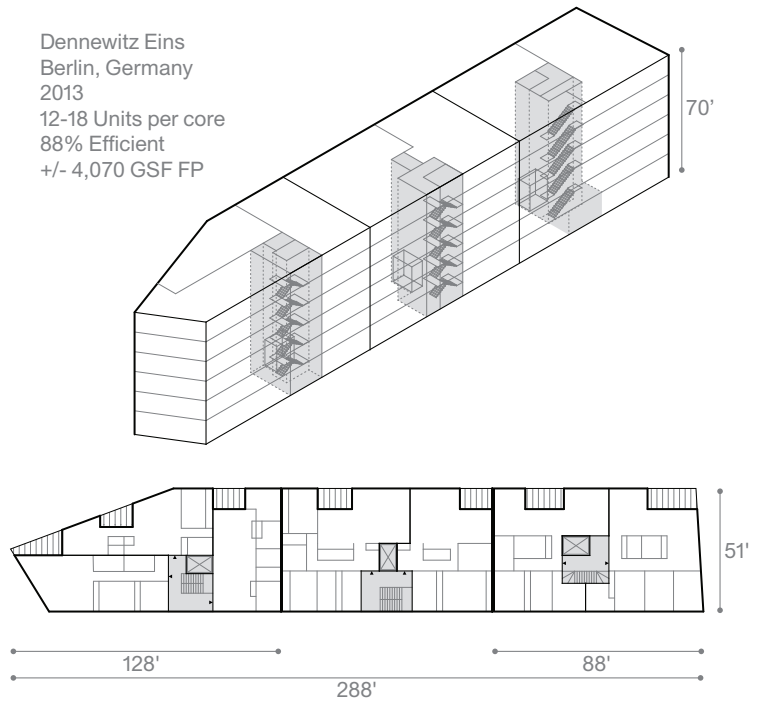

QUALITY OF LIFE

Without the requirement of two stairs, units in PABs can be arranged in a variety of ways around or next to a vertical circulation armature. In a double-loaded building, the only units that have dual aspect (access to more than one direction of exterior wall face) are on the ends or corners. In PABs, with the removal of a connective hallway, many more units have opportunities for direct sunlight and cross ventilation. If only half of units in a double-loaded building have access to direct sunlight (because they have windows on only one solar aspect), almost all units in a PAB can have access (because of the possibility for dual aspect units). More direct sunlight is better for passive solar gain, and more natural daylight on any facade means bedrooms are possible; making units more livable, sustainable, and family oriented. Cross ventilation, key to moving fresh air through a unit, or expelling hot air and bringing in cool air in the summer make it more likely residents use operable windows to improve indoor air quality and comfort in the least energy intensive method.

Double-Loaded Floor Plan
16,000 GSF Floor Plate
20 Units
88% Efficient

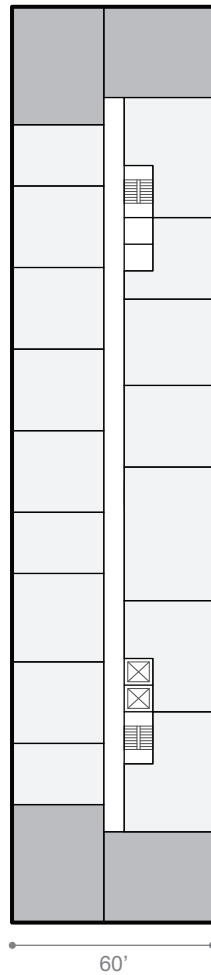

Point-Loaded Floor Plan

16,000 GSF FP
16 Units
91% Efficient

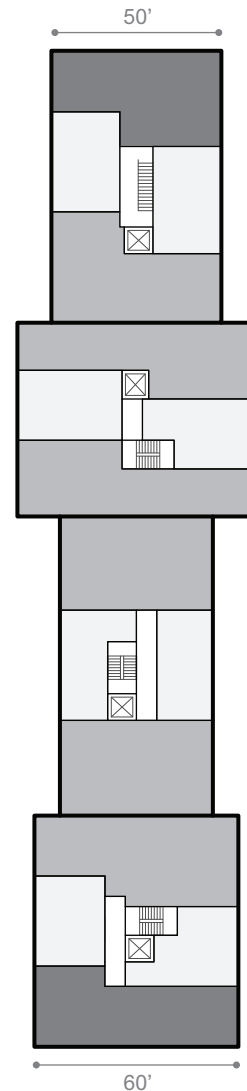

□ Single-Aspect □ Dual-Aspect □ Triple-Aspect

More windows means the opportunity for more bedrooms and thus more family-sized units. Increasing these units in multifamily housing production is key to creating buildings and neighborhoods that people can and want to live in for their entire lives. Double-loaded buildings disincentive these types of units. In Boston-area market-rate buildings, the typical ratio of units often amounts to a mix of 20 – 25% studios, 50% one-bedrooms, 20 – 25% two-bedrooms, and 5% three-bedroom units. Units with four, five, or more bedrooms are extremely rare, and three-bedroom units are reserved for end or corner units (which have more exterior window opportunities), making them naturally more expensive and less financially accessible to prospective buyers or renters. One reason for this deficit can be attributed to the geometry of the double-loaded floor plan. The connective hallway between the two stairs creates a fixed building depth (the hallway cannot be broken), and since every bedroom needs an exterior window by code, the only way to expand a unit's size is lengthwise.

Key Building Plans

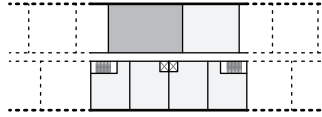

Double-Loaded Unit Plan

3 Bed / 2 Bath Single-Aspect

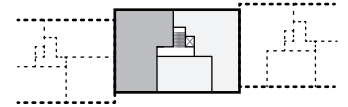

Point-Loaded Unit Plan

3 Bed / 2 Bath Dual-Aspect

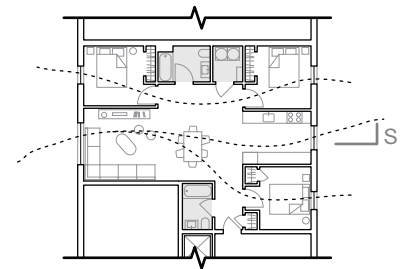
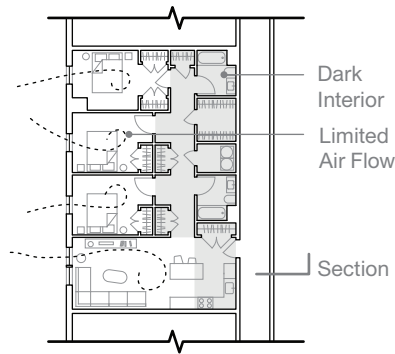

Unit Sections

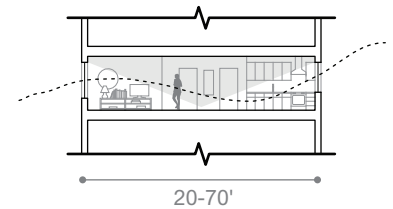
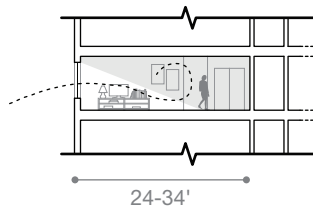

Growing linearly results in a proportional increase of the area without natural light. This darkened area then has less usefulness to a unit, and the resultant rental increase from its larger square footage is rarely justified fiscally or formally. PABs on the other hand, can essentially be buildings of only corner or end units, greatly increasing the flexibility of unit design to increase access to sunlight and cross ventilation, but also other spatial arrangements as well. PABs also incentivise family units, both because of their higher efficiency at smaller floor plates and the fact that, under proposed code reforms, any one single-stair building has a fixed number of units per floor, which encourages enlarging units rather than adding more smaller ones. While PABs might have fewer total units per floor plate when compared to a double-loaded construction, these units are typically larger, more diverse in layout, have more access to natural light and air, and are in compact buildings that otherwise would not pencil out on small to medium sized parcels.

Key Building Plans

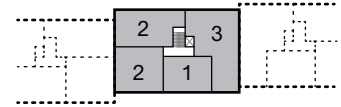
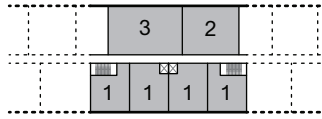

Double-Loaded Unit Plans

Point-Loaded Unit Plans

612 SF
1 Bed / 1 Bath

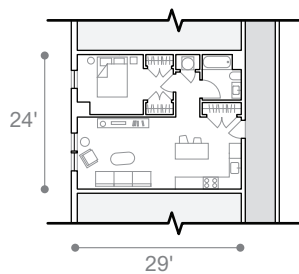

560 SF
1 Bed / 1 Bath

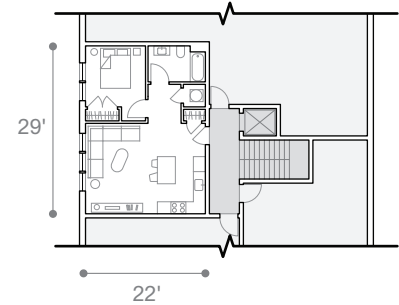

900 SF
2 Bed / 1 Bath

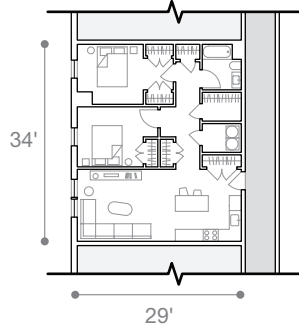

705 SF
2 Bed / 1 Bath

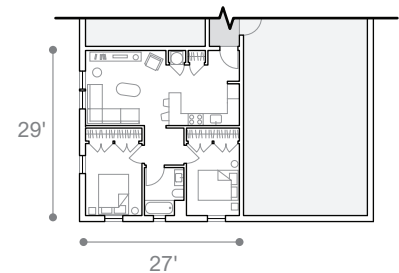

1,182 SF
3 Bed / 2 Bath

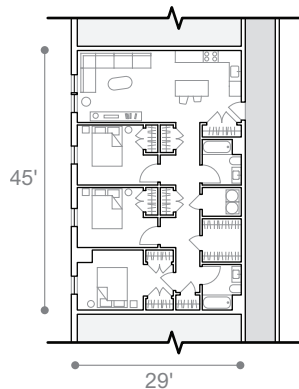

1,054 SF
3 Bed / 2 Bath

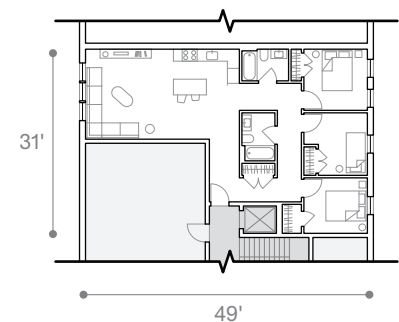

The central circulation core of a PAB also increases its opportunities for beauty and socialization. In a double-loaded building the endcap units, while hyper valuable, result in dim and often interminably long interior corridors. These hallways, rarely naturally lit, hurt the development pro-forma, and do no service to the residential design of one's front door. PABs without the need for a corridor are opened up to spending more money on the design of one single stair to be both more pleasant an experience and compact a pathway to one's home. In surveyed projects natural light was more prevalent in these types, either from the stairway's being pushed to the side of a building, or being placed between two volumes with a light well in between. The single stair (and often elevator), is also part of a sequence of circulation that everyone must pass through and by which residents might run into neighbors more often. In buildings under this proposal, which would be permitted to have 20 units served by a single stair on the five upper stories (as opposed to over a hundred in the typical podium building), social cohesion of residents and neighbors can be imagined in greater clarity when the journey from the street to one's sofa is bright and compact rather than boring and claustrophobic.

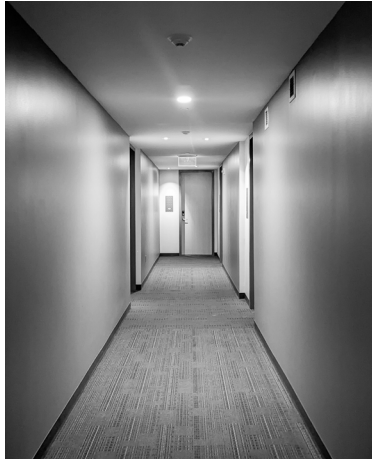

Boston

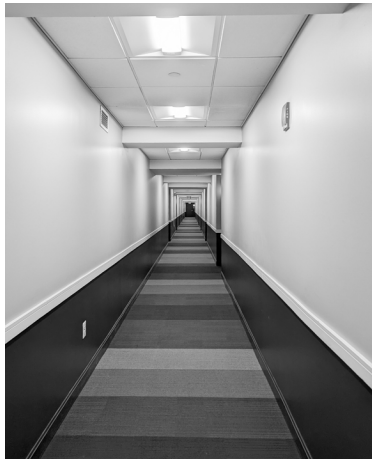

Boston



Boston



Australia



Switzerland



Australia

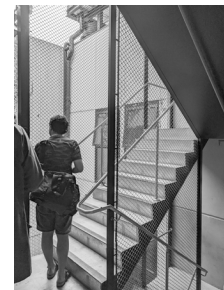

Australia



Switzerland



Netherlands



Argentina



Australia

UNLOCKING DENSITY

In Greater Boston,² very few units are created in buildings with more than nine but fewer than 30 units. A key to understanding this outcome is that buildings above 12 units or more than three stories require two means of egress.³ While double-loaded buildings provide high efficiency at larger footprints, they suffer greatly on small to medium sized parcels. Thus, those sites remain underdeveloped, or lie in wait to be bought and aggregated into larger parcels which are more suitable for a podium style development scheme. Greater Boston cannot wait for those aggregations, and shouldn't settle for only one scale of mid-rise housing. PABs are well suited to small and medium scale parcels, and with one less stair, and way less hallway, can achieve much higher floor plan efficiencies than their double-loaded counterparts. New England's old city fabrics have a multitude of parcels at this smaller scale, often on existing transit-friendly squares and streets that are primed for more development, but, without a change to the building code, remain unprofitable to develop as such.

On a typical six-plex Boston parcel, which ranges from 3,000 – 5,000 square feet (the most common parcels in size in Greater Boston), a double-loaded building is 10% less efficient than a similarly sized single-stair building. The extra stair and attendant hallway accounts for around 280 square feet, or 10% of the total floor area. This can account for equally 10% or more of the total construction cost of a project (anywhere from \$200,000 to \$500,000),⁴ and considering that the same area is rentable in

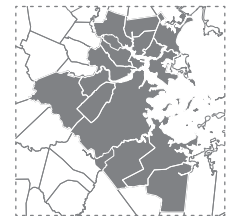
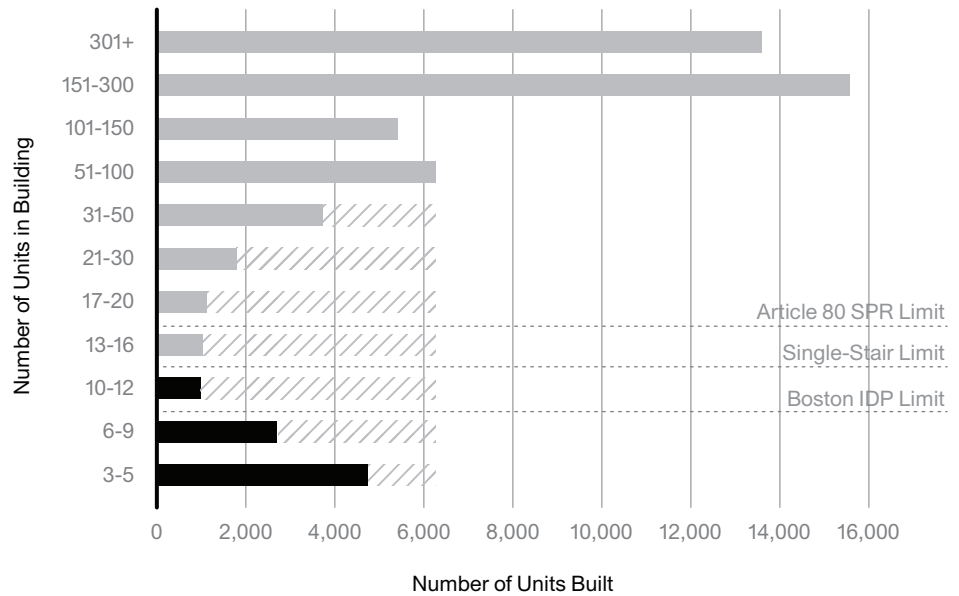

Small Double-Loaded Plan
82% Efficient

2,880 GSF Floor Plate
3 Units

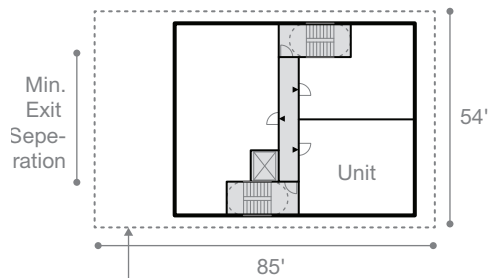

Small Single-Stair Plan
92% Efficient

2,880 GSF FP
3 Units

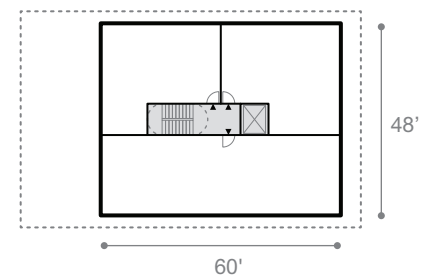

Median Parcel Size in Greater Boston (4,600 SF)

a single-stair building, it could represent an even greater hit to the pro-forma. The cost is enough to break most budgets and make these kinds of sites unbuildable in the current market.

Single-stair mid-rise PABs can fit into these sites right now, and have a circulation armature which allows for massings to be broken up; which could also break down the notoriety of new development. The narrative of any new housing, when talked about in community meetings or elsewhere online, evokes for many the image of a bulking and characterless podium-style building of uniform height, shape, and facade. The necessity to connect two stairs, both in plan with an efficient corridor, and in section, so that every unit can access both stairs, results in architectural designs unable to modulate their massings beyond minor moves of a few feet. PABs on the other hand, which have no hallway and are limited in floor plate size, can be clustered together in arrangements that can step up, down, or laterally—differentiating their urban form in more meaningful ways. The allowance of a single stair is critical to achieving the kind of urban variety that our cities need and that the public deserves but, without a change to the building code, will be only seen abroad or in unrealized designs not yet subject to the realities of market-driven housing production.

Mid-Rise Double-Loaded Podium
Limited Massing Options

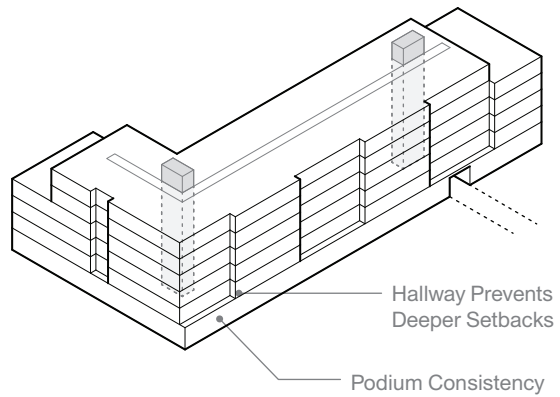

Mid-Rise PABs in Sequence
Variable Massing Possible

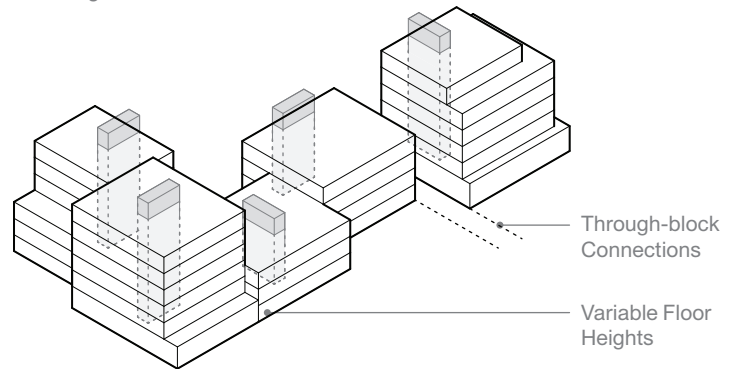

II. Greater Boston Housing History

RESILIENT RESIDENTIAL TYPES

Most of Boston's best-known housing typologies, such as the triple-decker, Back Bay rowhouse, or Fenway brick apartment houses, also originated from market logics and construction constraints of their day. The triple-decker is a useful case study because, like the five-over-one, the building type resulted from a confluence of several technical, regulatory, and market factors. When waves of newcomers, including Irish and Eastern European immigrants, arrived in Boston in the late 19th century, and expanded streetcar networks made longer distance commuting more feasible for the lower middle class, vast new areas in Dorchester and Roxbury were developed as residential neighborhoods. Given the relatively low land values and the need to build new housing quickly and cheaply, a novel housing type was developed that didn't require semi-skilled masons or the dimensional precision necessary for zero-lot-line rowhouses, the preferred typology of central Boston for the middle and upper classes. The answer was a free-standing wood frame three-story building with a different family living on each floor: the triple-decker. The maximum number of stories of the triple-decker was fixed by the maximum standard length of mass produced lumber as the result of recent industrial technologies. Balloon framing, a construction innovation that took advantage of these new lightweight and more precisely cut framing components, meant that structures could be assembled very quickly by unskilled labor. Housing production was further accelerated when developers could sequence construction trades crews across dozens of parcels.

627 – 629 Commonwealth Ave.
Boston, MA

Stories 4
Built 1908

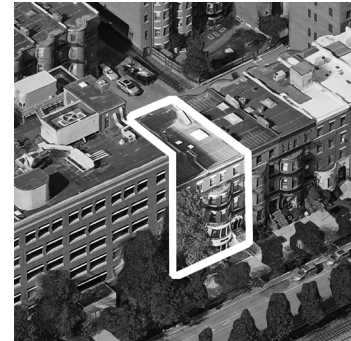
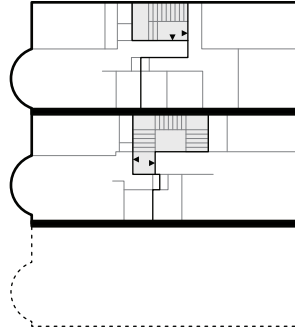

728 Commonwealth Ave.
Boston, MA

Stories 5
Built 1912

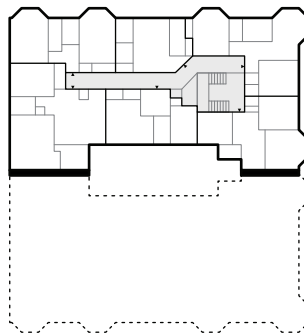

842 – 864 Massachusetts Ave.
Cambridge, MA

Stories 3 – 5
Built 1925

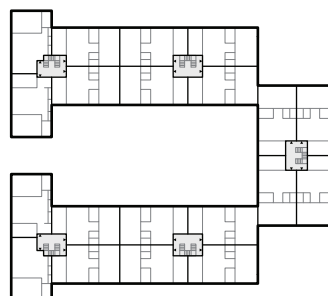

This market flexibility, coupled with the optimization of land use and construction efficiency meant that the triple-decker was the most common multifamily residential building type built in New England cities from the 1880s until the 1930s.

While the triple-decker now represents a cherished part of the urban fabric, at the time it was simply the most efficient means of housing the most people at the least cost in the shortest time. Today that product is the podium building, and, while its cultural relevance remains to be seen, its inflexibility to fit into the fine grain urbanism of the region has left many communities wary of any new development, affordable or not. Similarly, this form is less conducive to fitting on parcels within the fine-grain urban fabric in Massachusetts, as demonstrated in fewer new housing units per capita when compared to other states.⁵

Single-stair buildings here have, to varying degrees, been permitted for most of the 20th century up to the mid-1970s. A survey of these types reveals the pervasiveness of existing mid-rise, and in some cases high-rise housing. Many Bostonians live in single-stair buildings, and their relative compactness (in contrast to podium buildings today), has shaped an urban fabric that can support walkable and transit oriented life. If the city's own past is any lesson, and if international precedents can be instructive, single-stair mid-rise buildings might be deemed as the triple-(or more)-decker of the future.

24 Highland Ave.
Cambridge, MA

Stories 5
Built 1950

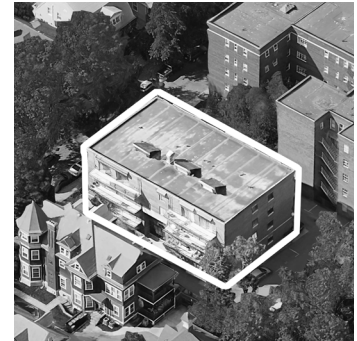
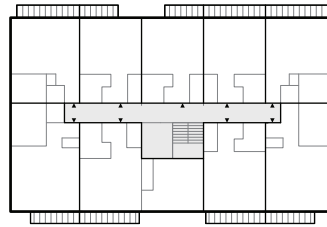

1350 Massachusetts Ave.
Cambridge, MA

Stories 5 – 22
Built 1964

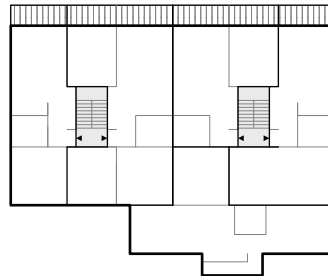

1105 Massachusetts Ave.
Cambridge, MA

Stories 13 (Scissor Stair)
Built 1970

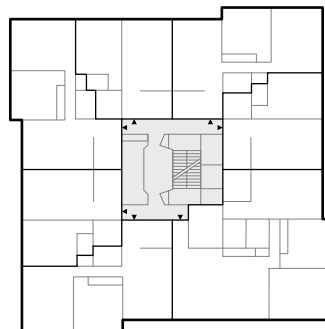

AN EVOLVING BUILDING CODE

In 1630 Boston outlawed the building of wooden chimneys and thatched roofs, creating what is now understood as the first formal building code in the US. Boston grew its own code over the years, and it became a model code for surrounding towns and cities as well. In 1974 the Commonwealth created the first statewide code (first edition), which has evolved but remained under the state’s purview until today; cities must follow it and cannot make regulations that are more permissive

than what the state regulates. The current edition (ninth) of the state code is an amended version of the model International Building Code (IBC) 2015 code, and was adopted in 2017 by Massachusetts. In late 2024 the state will formally adopt the 2021 IBC under the new tenth edition of the code. The IBC is the most commonly used model code countrywide; however, each state and some cities adopt different versions, with Vermont and Georgia adopting parts of the National Fire

Protection Association (NFPA) code in lieu of IBC for the sections pertaining to the number of means of egress.⁶

Throughout the time when Boston had its own building code, single and dual egress requirements varied. Despite references to the requirement for two means of egress dating as far back as 1803, single-stair residential buildings were built of varying heights up to the mid-20th century. During some periods the code allowed one to egress through

Timeline of the Boston Building Code

1630
City of Boston is officially founded.

1760
The Great Boston Fire destroyed 349 buildings displacing thousands of people.

1871
The city’s first Building Department was established by Chapter 280 of the Acts of 1871.

1872
The Great Boston Fire destroyed 65 acres of buildings.

1873
(S. 44) “Every building must have a fire means of escape approved by the inspector of buildings.”

1895
(S. 81) “Every building occupied by two or more families, shall have one or more safe means of egress, satisfactory to said commissioner.”

1901
(S. 82) “Buildings two stories or more shall provide at least two independent ways of egress. One shall consist of a flight of stairs from the lowest to the highest floor. The other shall be approved by the building commissioner.”

1907
(S. 54) “All tenement houses three stories in height shall provide one of the following means of egress: (1) an interior stairway; (2) an exterior iron fire-escape and stairs; (3) iron balconies.”

1915
BOCA was established to provide a forum for the exchange of knowledge and ideas about building safety and construction regulation.

1944
(S. 1803.e) “Every story in a building shall have at least two remote exits. (S. 1812) “Fire escapes shall not be erected to serve as required exits except from post-code buildings four stories or less in height and five thousand square feet or less in area.”

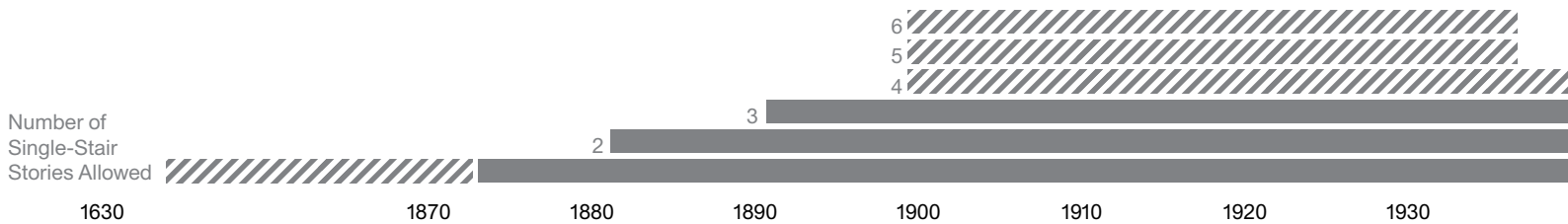

Boston	Digest of the Statutes Relating to the Survey and Inspection of Buildings in the City of Boston
State	In Massachusetts building codes were done municipality by municipality, and some simply adopted Boston’s code as their own

In 1630 Boston outlaws building wooden chimneys and thatched roofs becoming the first formal Building Code in the United States.

On July 8, 1871 the city council of the city of Boston established and defined the limits with which all buildings shall conform establishing the Digest of the Statutes Relating to the Survey and Inspection of Buildings.

another unit to reach a stairwell. When that provision was overridden, the requirement for retrofitting exterior fire escapes and fire balconies became common. As the city grew, older buildings were often subdivided into more dwelling units, often requiring these adjustments, and sometimes even the addition of a new interior stairwell or automatic sprinklers.

In 1974, with the adoption of the first statewide code, single-stair buildings

were heavily curtailed. Research shows the maximum height allowed was lowered to two stories, and a survey of existing structures built during this time did not find any new buildings of this type. It wasn't until 2017, with the adoption of the current code version, that three-story single-stair buildings were once again allowed and began to be built again (albeit in limited number and size).

Terms

BOCA	The Building Officials and Code Administrators International
IBC	International Building Code
ICBO	International Conference of Building Officials
ICC	International Code Council
SBCCI	Southern Building Code Congress International

- 1970**
(611.1) "Exitways shall not pass through another living unit."
(611.3) "Only one exitway shall be required in multi-family dwellings, not more than, three stories in height for not more than six families or not over two stories and attic in height, for not more than eight families, nor more than four families to a floor."
- 1974**
(609.1) "There shall be two or more exitways serving every floor area above and below the grade floor."
(609.12) "In buildings of type 1-A or type 1-B construction a single exitway shall be permitted for every room, or group of less than four rooms used for residential occupancy on multi-family floors."
- 1987**
BOCA adopts codes requiring sprinklers in multi-family structures
- 1990**
(807.4) "Exits shall be placed as remote from each other as practicable, and shall be arranged to provide direct access in separate directions from any point."
- 1994**
BOCA, SBCCI, and ICBO merged to form the ICC in order to develop a singular set of building codes.
- 1997**
(904.7) "An automatic fire suppression system shall be provided throughout all R-2 buildings, except buildings having no more than three dwelling units."
- 2000**
The first edition of the IBC was published by the ICC.
- 2008**
(1018.2) "One exit allowed for maximum height of 2 stories with 4 dwelling units per floor and 50 feet travel distance equipped throughout with an automatic sprinkler system."
(1014.2.1) "Interlocking or scissor stairs shall be counted as one exit stairway."
- 2010**
(1018.2) "One exit allowed up to three stories, 4 dwelling units per floor and 50 ft travel distance."
- 2017**
MA Adopts the IBC 2015
- 2024**
MA Adopts the IBC 2021 (current code)

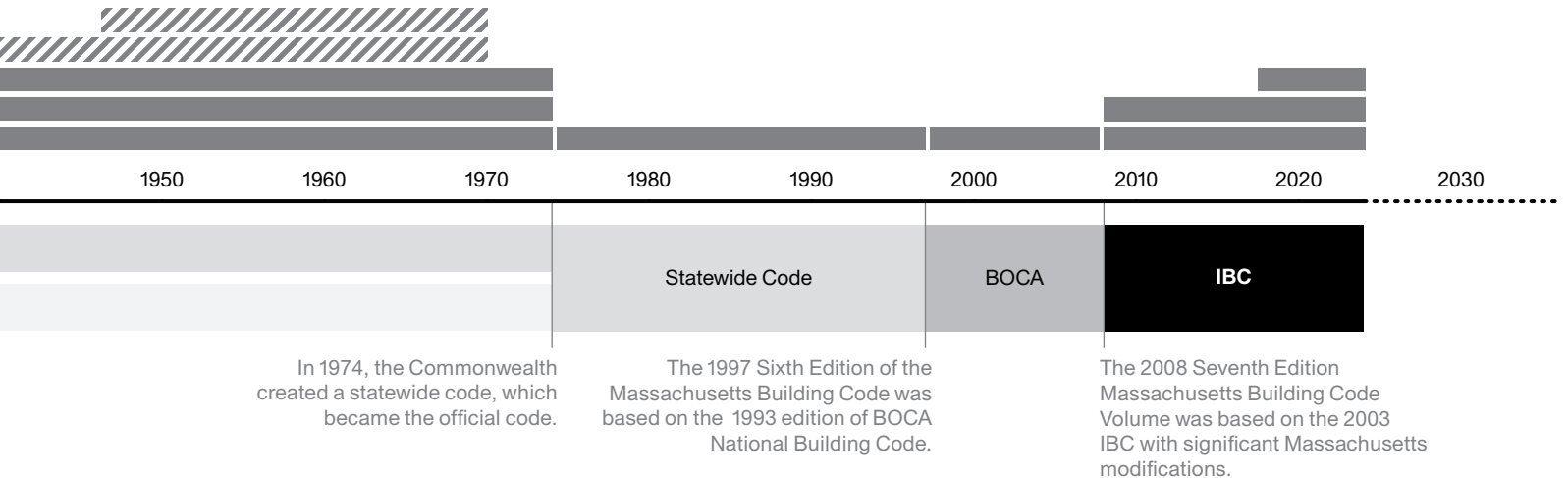

SINGLE STAIR TODAY

In the current building code the height of a single-stair residential building for multifamily use (classified as R-2, or non-transient residential use) is limited to three stories above grade. The number of units is further limited to only four on each floor, with a maximum of 12 units in any building. The building must also be protected with an automatic sprinkler system, and its windows must be of a certain size and operability to meet emergency and rescue escape requirements.

While this is what the code allows, it is not always what gets built. A survey of recently built single-stair buildings in Greater Boston found that few maximize their unit count, with most having seven or nine units. In Boston the threshold for inclusion of income restricted housing units, (typically 13% of the total units), kicks in when you have 10 or more units. Site factors, including parking, transformers, and other building services, further constrain the ground floor of any

given building, and with a maximum unit count per floor, result in fewer units overall. While the number of units is limited, the size of units are incentivised to grow in order for developments to gain more net area. While the code limits the number of building stories, if units themselves are multistory (i.e., duplex or maisonette), projects can essentially add another story to the building while keeping within the letter of the law. The fourth floor then does not need access to the common staircase entirely and is 100% efficient.

While the duplex exception incentivises larger multistory units, it's also only possible in Massachusetts if the building does not have an elevator (due to the units thus not being "accessible" under 521 CMR⁷). As a result the limitation of single-story buildings to 12 units and three stories actually results in buildings with four to nine units, up to four stories, and with less overall accessibility within

them. The market will always seek to exploit underlying zoning and the building code to produce the maximum return on investment, which usually means the maximum residential floor area. As desirable as this type may be for few more well-off people to enjoy larger units in small buildings, it's a burden to folks who are presently shut out of the housing market, and would greatly benefit from increased supply and more accessible homes—an end only possible through a code that prioritizes scalable mid-rise housing within predictable guidelines.

Section 1006.3.2 (Single Exit)

Occupancy	R-2
Max. Units Per Floor	4
Stories	≤ 3
Max. Exit Access Travel Distance	125'

+ Equipped with an Automatic Sprinkler System

+ Equipped with Emergency Escape and Rescue Openings

Existing Single-Stair Limits

Axonometric

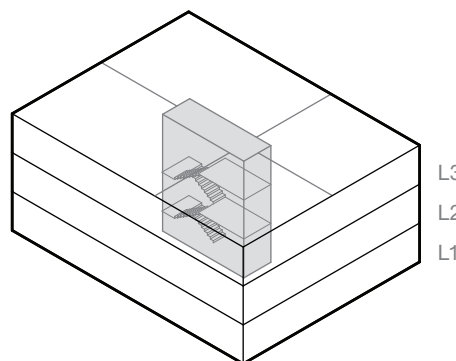

Floor Plan

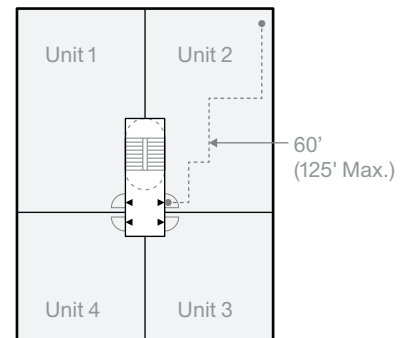

Recently Built Single-Stair Buildings in Greater Boston



34 – 40 Chestnut Ave.
Jamaica Plain, MA

Units 4
Built 2012
Floor Plate 2,545 GSF



471 Somerville Ave.
Somerville, MA

Units 5
Built 2020
Floor Plate 4,810 GSF

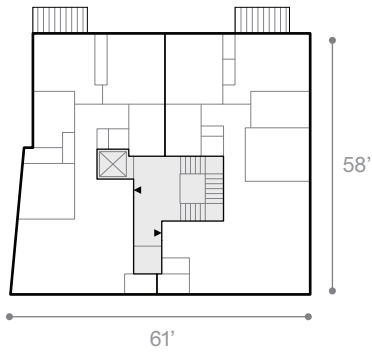

191 Condor St.
Boston, MA

Units 9
Built 2023
Floor Plate 3,187 GSF

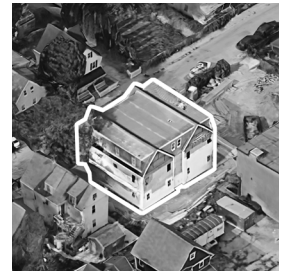
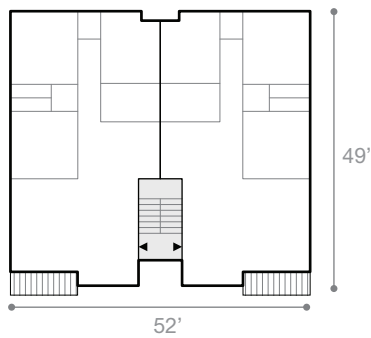

8 Oakhurst St.
Dorchester, MA

Units 4
Built 2023
Floor Plate 2,480 GSF



110 Savin Ave.
Boston, MA

Units 9
Built 2019
Floor Plate 3,980 GSF

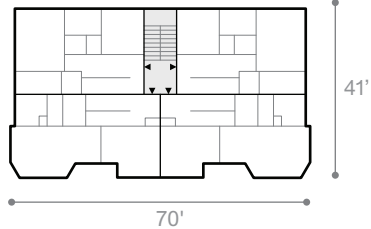

490 Bennington St.
East Boston, MA

Units 7
Built 2024
Floor Plate 2,630 GSF

III. Egress Code Landscape

THE NORTH AMERICAN OUTLIER

Across the world, the United States and Canada are outliers in terms of their constrictions on single-stair multifamily housing. Only Uganda, South Africa, and Pakistan also have height restrictions at or below three stories; while some countries (South Korea and Switzerland) have no limit at all.⁸ Countries comparable to the US by climate, economy, and urban development generally allow single-stair buildings of six to nine stories, right at the threshold to being above rescue from the ground and thus becoming “high rise.” The US limitation arose with our divergence from the rest of the world in housing development patterns, but has not been re-evaluated under recent changes in both fire-protection strategies and urban housing challenges.

Compared to the rest of the world, North America is unique for two primary fire safety reasons: light wood-frame construction and the historical low density of our housing stock. Light wood-frame construction (as opposed to engineered wood or heavy timber wood) is rare elsewhere (perhaps excluding parts of Scandinavia). The abundance of forests here has allowed standard stud framing to be the favored building material for both single-family homes and multifamily buildings, and has been since our cities started growing. In most other parts of the world wood was used early on, then masonry bearing walls with wood infill framing, and ultimately cast-in-place or precast concrete became the favorite residential building material. Wood being far more combustible and flammable than concrete necessitates additional fire protection measures, both

Legality of Single-Stair by Number of Stories



Sourced from City of Vancouver Report on Point Access Blocks (Eliason, 2021), and from Second Egress: Building a Code Change

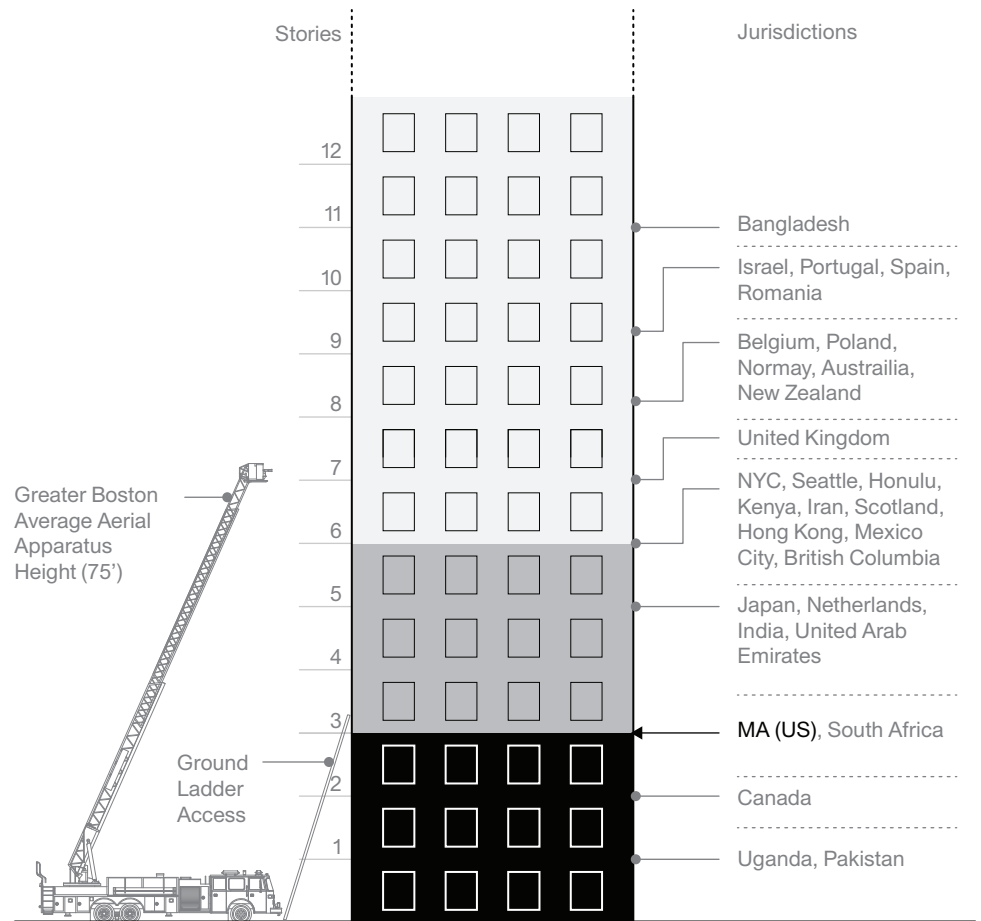

active and passive. As many other countries, particularly those in Europe, became space constrained, noncombustible construction and less spatially draining egress requirements were natural solutions to allow development at a density that could support growth in cities. In contrast, the US grew most prominently through suburban sprawl (its housing mostly in the form of single-family homes spread out from each other), and in low to medium density urban expansion (which mitigated fire spread through zoning side yard setbacks and limited density per acre).

Over the last century, advancements in fire protection measures and technologies have made our buildings much safer, making the reconsideration of the two means of egress possible while maintaining equal or greater safety, even in light wood-framed buildings. Similarly, our current affordability crisis mandates that we think more creatively about construction cost and urban typologies, making the reconsideration of the building code just as critical as that of the zoning code. Currently, fire protection measures in our code range from active to passive. Passive measures include limiting building sizes, heights, and setbacks, but also modern advancements in covering wood with nonflammable materials such as gypsum board (drywall), and fire-stopping or smokeproof doors and sealants to compartmentalize different units or spaces within a building. Active building measures, of which most are modern, range from automatic door closers, smoke detectors, smoke control technologies; and automatic sprinkler systems; in addition to fire service advancements such as

Average Number of Fire Deaths per 100,000 Inhabitants (2018-2022)

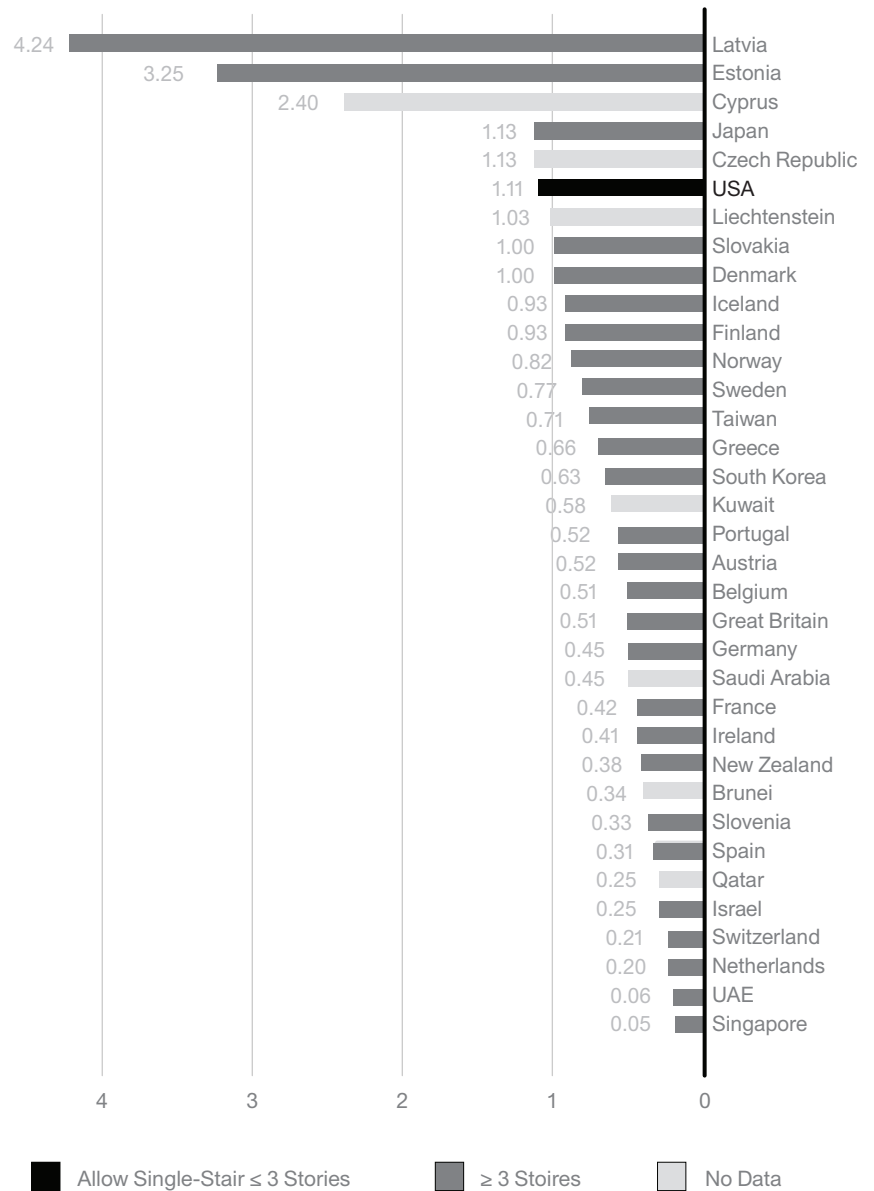

From the Center for Fire Statistics World Fire Statistics Report, No. 29 (excluding countries with less than \$25,000 GDP per capita)

ladder trucks (aerial apparatuses), fire hydrant proliferation, and widespread fire safety education in our schools.

The requirement for two means of egress arose sometime in the early to mid-20th century, a passive measure to ensure redundancy during a time when building practices and fire prevention and attack strategies were inconsistent and unstandardized. It has remained on the books due to its seemingly obvious benefit, along with respect for previous fire prevention decisions and an inclination to leave them in place unless robust, scientific, and consensus driven processes show alternatives are equally effective. However, compared to other countries our own fire record is not stellar, and the requirement of two means of egress should be reconsidered alongside advancements in fire prevention, but also in the context of most countries having deemed mid-rise buildings of limited floor area with one stair adequately safe.

Comparing fire loss data across countries is not precise, but it does offer a perspective on how the active and passive measures influence fire loss.⁹ A comparison of high-income countries shows that the US is tied for the highest fire death rate, and that people in the US are roughly five times more likely to die in fires than Swiss people are, despite Switzerland allowing single-stair buildings of unlimited height, and sprinklers being very rare.¹⁰ A large part of this story has been attributed to the fact that most Americans live in single-family homes, which are almost always unsprinklered, mostly made of light wood framing, and with less professional design

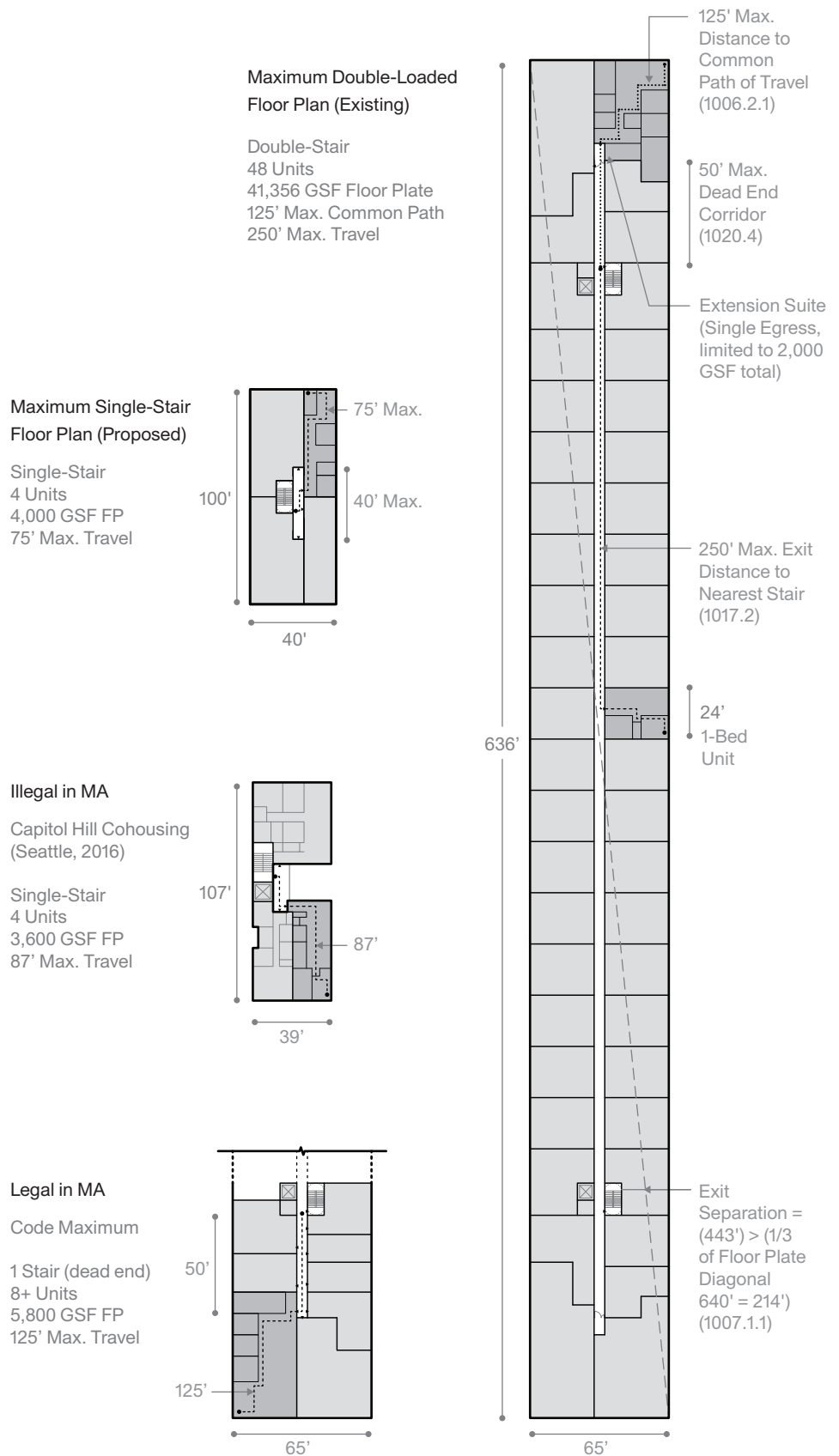

and maintenance. In fact, research estimates that 99% of home fire deaths occur in buildings without sprinklers, and the death rate per fire is more than eight times higher in buildings without sprinklers.¹¹ In another study it was shown that, in 95% of fires, the fire does not spread beyond the room of origin, further emphasizing the benefits for sprinklers and compartmentalization in construction and downplaying the impact of a fire occurring in a stairwell or hallway.¹² These facts, combined with the fact that the vast majority of fires (91%) occur in buildings without working sprinkler systems, weaken the argument that redundant staircases are our best defense against fire, even in small to medium sized buildings. Any new single-stair construction would certainly include sprinklers.¹³

In other countries the requirement of two stairs does exist, but generally for much larger or taller buildings. The logic is predicated on two assumptions. First, in the event of a fire and one exit is blocked, the other one remains available. And second, that in that fire event, one stair could be used for egress, and the other could be utilized by firefighters for attack. There are a number of facts that make these considerations less necessary for the mid-rise single-stair buildings this report focuses on. Firstly, fires and smoke in hallways or stairs (which are required to be sprinklered) are very rare. Fires that originate in stairwells or corridors from arson or other sources are so uncommon that FEMA does not mention them once in its 2021 report on building fires, which mines local fire department reports through the National Fire Reporting Systems data (kitchens and bathrooms rank

the highest). Secondly, in the event one stair is blocked, the separation of fire attack from resident escape becomes impossible; and in practice it's also rare if at all possible (based on interviews with fire service officials, residents use whichever exit is closest), and in mid-rise buildings under this proposal it is more than likely that most residents will have evacuated the building far in advance of the fire department's arrival in the first place.

But finally, and most importantly, the scale of buildings being proposed are much smaller than those possible with two stairs, meaning the amount of people exiting per stair might be five times less than in a typical podium building, and at most equal to the amount of people currently permitted to exit through a single exit in a dead-end corridor condition. Under current codes, the maximum building length of a double-loaded podium building is more than 630 feet. In such a building any given resident could have to travel as far as 250 feet to a protected exit stair (the maximum travel distance to the nearest stair). For residents in units at the ends, who have only one exit option because of the dead-end corridor, the maximum travel distance can be as great as 125 feet, and the number of units with access to only one stair is theoretically unlimited. In the single-stair building being proposed in this report, the maximum number of units, the maximum travel distance, and the maximum floor plate size would be limited to far less than is currently permitted for a two-stair building. The result is that the number of people exiting per stair is far less, and the length of distance to travel from a unit through the hallway to a

protected stair could be less than a third of that in a two-stair building and at most, half as far.

While the status quo double-loaded building maintains two choices for egress, market logics push for distances far greater than would be possible under mid-rise point access blocks. Shortening this distance, a boon for egress, also benefits residents on a daily basis; offering more social encounters, less distance carrying groceries, and a shorter route for less able-bodied people. These passive measures of reduction in size, combined with existing requirements for fire-rated walls and sprinklers should more than compensate for the lack of redundancy in exit access. Additionally, when considering that one could build today a building of up to six stories, with the dead end of it having only one exit and five to ten units using that exit, this report is actually proposing *raising* fire safety standards by limiting the area and units of a PAB—which, combined on a lot with fire wall separation, offers greater safety and compartmentalization than found in most double-loaded buildings.

A CHANGING LANDSCAPE

While most states dictate the IBC limit on single-stair buildings (three stories), there are outliers and a momentum of change across North America. For many years both New York City and Seattle have allowed (with some conditions and caveats) up to six stories of single-stair multifamily housing, and more recently Honolulu re-legalized them to follow the Seattle model code. In addition, successful legislation in California, Oregon, and Washington

state will make mid-rise single-stair buildings legal in either 2025 or 2026. Nine additional states have ongoing efforts to study and legalize these buildings. So do the Canadian provinces of Ontario and British Columbia, with guidelines for performance-based code compliance under review within the City of Toronto. Finally, a pending proposal to liberalize the use of PABs is being considered by the International Code Council (ICC), the organization that writes and publishes the IBC. While this movement, which began in earnest perhaps five years ago, is gaining momentum, it builds upon older studies such as a 1984 Canadian report entitled “Fire Safety and the Design of Apartments, a report to the Canada Mortgage and Housing Corporation”. It includes recommendations for assessing the National Building Code of Canada to allow up to eight stories of single-stair housing. The report references the same urban strains, both economic and spatial, that our

cities struggle with today, and the inflexibility of their building code to provide relief. Specifically called out is an analysis between European and Canadian building layouts and fire safety records, which shows Europe far exceeds Canada in fire safety, even while offering more flexibility in European apartment layouts.

Today, the topic of single-stair housing has made headlines in multiple design competitions, articles, videos, panels, presentations, and podcasts (many of which are included at the end of this report for further reading).¹⁴ Much of the push has been led by housing activists, policymakers, architects, urban planners, and urbanists. The building code, which has long been the domain of trade groups and regulators, is starting to be understood as an equally important regulatory tool as zoning; to be effective, both require constant dialogue between those who work under them

and those who write them. The American Institute of Architects, in its statement about building codes, says, “As a group, architects may be the most significantly affected by, and the most significant users of, the codes.” Yet, among the 109 members of the ICC’s Industry Advisory Committee, which writes the International Building Code most states adopt, two are architects. Of the 16 members of the Massachusetts Board of Building Regulations and Standards, which adopts the model building code for the state, just one is an architect. While architects are only part of the missing picture, this report contends that the lack of architectural engagement in lobbying for the public’s best interests must be reversed, and code councils would do well to hear arguments from those working directly in areas most in need of creative spatial and typological solutions.

Code Change Landscape in the US & Canada

Courtesy of the Single Stair Tracker from The Center for Building in North America

- Currently Legal**
 - New York City
 - Seattle (1977, modified)
 - Honolulu (2012, re-legalized)
 - British Columbia (2024)
- Pending but Accepted¹⁵**
 - California
 - Oregon
 - Washington State
- In Progress States/Cities**
 - National
 - Canada (NBC Proposal)
 - US (ICC Proposal)
 - States/Provinces
 - Colorado
 - Connecticut
 - Cities
 - Austin
 - Nashville
 - New York City floor plate size
 - Toronto (Canada)

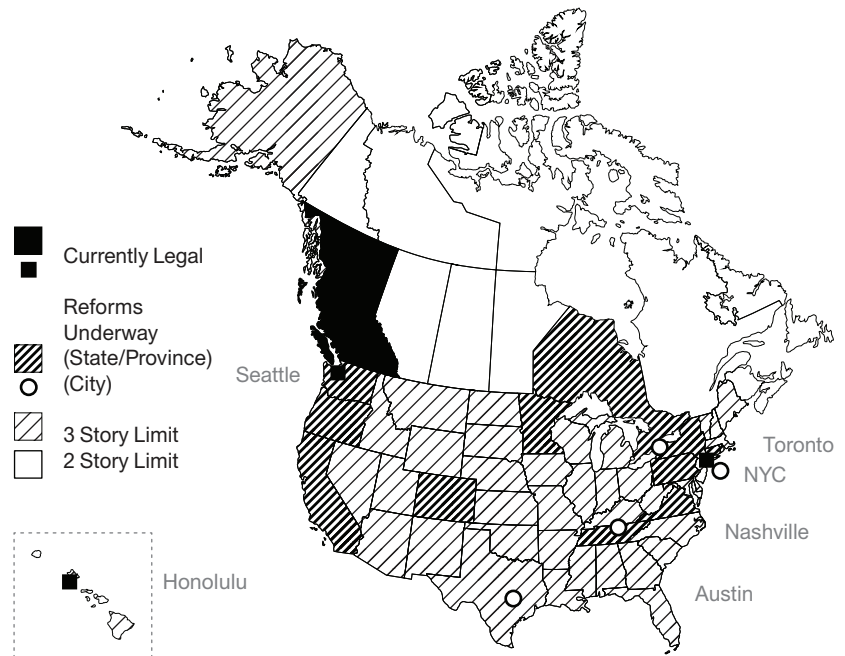

THE PROPOSAL

The goal of this proposal is to enable more diverse housing typologies that fit into existing urban form while not compromising the safety of residents. Based upon our research we recommend that the following provisions in the table below be followed for any single-stair multifamily building.

This recommendation raises the height currently allowed by three stories, doubling the number of units possible in a PAB from 12 to 24. It does not increase the maximum units per floor, or any other fire protection feature currently applied to single-stair buildings. Similarly, the same occupancy requirements, non-high-rise

characteristics, and shaft or enclosure fire-wall ratings would still apply. PABs of up to six stories and up to 24 units offer more favorable potential financial returns for small lots. Those lots then can have more units close to transit and other neighborhood amenities. And those units can be larger, and have more access to natural light

Proposed Requirements

- 4 maximum units per floor
- 6 stories maximum (non-high rise)
- 4,000 GSF maximum floor plate
- 75' maximum exit access travel distance
- 20' maximum corridor length
- 45-minute minimum rated unit entry doors

Additional measures (if not already required)

- Equipped with a NFPA 13 sprinkler system
- Two-hour rated exit stair (smokeproof enclosure)
- Equipped with emergency escape and rescue openings
- Buildings can be mixed-use, but other occupancies cannot be above the ground floor

Optional Measures

- Exit stair discharge requirements such as mandating it directly exit to a public way and cannot be through another occupancy or a residential lobby
- Stair smoke control features such as pressurization, stairwell emergency smoke ventilation systems, or exterior stairwells
- Even higher unit entry door rating requirements
- Noncombustible construction type limitations

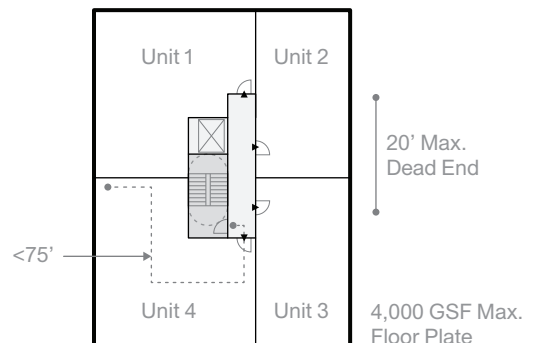
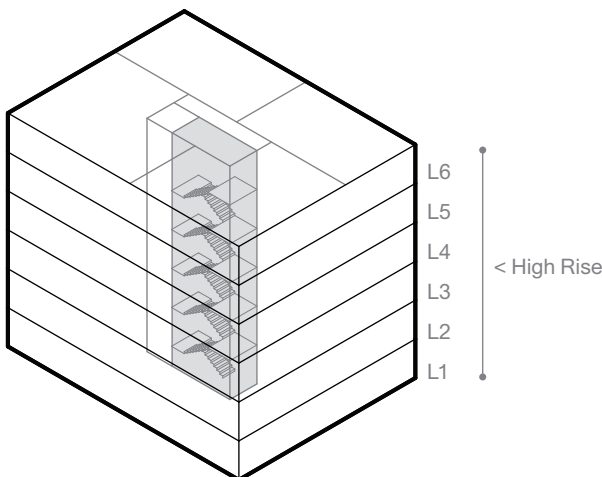

and air than units in typical double-loaded corridor buildings. In terms of fire safety, the six story maximum follows the mid-rise logic adopted by other domestic municipalities and by most other comparable countries. This proposal limits the number of occupants in possible danger and the potential fire spread by limiting the size of buildings and floor plates, while the maximum travel distance shortens the time it takes to exit or be rescued. Upgrading unit entry door fire ratings from 20-minute (typical in a 1 hour rated corridor) to 45-minute aids in the prevention of any unit fire spreading to the corridor. Existing provisions for sprinklers, exit enclosure ratings, and smokeproof construction ensure the building would match or more likely exceed the fire protection design of any six-story building built today.

Compared to a traditional double-loaded podium building this proposal calls for a massive reduction in floor plate size. Each floor plate on such a building could be as much as 100,000 GSF depending on construction type, compared to just 4,000 GSF for buildings under this proposal. The maximum corridor length of 40 feet would also be 14 times shorter than the longest corridor in a double-loaded building today. The building would be required to not exceed the high-rise code threshold, ensuring code exceptions such as the duplex or mezzanine exploits would not overburden the height.

As a part of future efforts, potential additional protections to be considered are: smoke control features such as pressurization and stairwell emergency smoke ventilation systems, even higher unit entry door rating requirements, and noncombustible construction type limitations.

Finally, this report does not recommend limiting mixed uses (just that the stair cannot serve or exit through those uses), limiting the number of PABs on a single parcel (as Seattle's code does), or mandating window rescue as a strategy, since these would limit windows on a building to only facades facing a public street, and negatively impact the urban design benefits provided by PABs.

This proposal is a call to all those who work on housing to consider how the building code in general, but specifically in relation to two means of egress, can be adjusted to allow for more mid-sized multifamily housing. One path of reform would be to have the legislature commission its own report on the issue. This report could include:

- Comparisons of fire prevention strategies and outcomes between successful US single-stair jurisdictions, and those abroad.
- Conducting a quantitative risk assessment of different housing typologies; both single and dual stair.
- Conducting a cost comparison between single-stair and double-loaded developments.
- Defining the exact code proposal and language to be adopted as part of the model code amendment cycle.
- A survey of municipal fire service departments to understand where it makes sense for this allowance to be made, and where it does not.

An outcome of the state's report might be code language that the regulatory committee could utilize and set provisions for its optional adoption by any city's inspectional services department. Ultimately, Massachusetts

lives within the context of a federalist nation, in which certain standards make sense to be federally applied and others not. In this case, Massachusetts can be a model for other states or the county as a whole to follow. Our reputation as "first in the nation" on many other initiatives positions us to lead the effort in developing a robust, scientific, and consensus-based pathway to legalize mid-rise PABs.

RELATED BUILDING CODE PROVISIONS WORTH RECONSIDERATION

In addition to the focus of this report, egress requirements, the following related building code limitations are also worth serious consideration for revisions: the high rise height limit, ground floor unit accessibility, and exterior stair allowance. All three tie closely into making single-stair housing better and more efficient, and have been undervalued for their provision to enable more numerous and delightful housing.

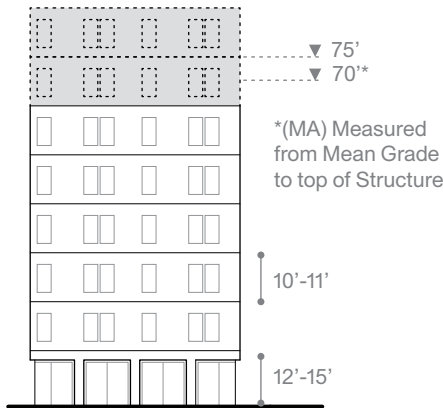

Raise the High-Rise Limit to 75'

Massachusetts, in its amended adoption of the IBC, limits high-rise buildings to 70' instead of 75' as is allowed in most states and under the model code. As a result, developers prefer buildings of 69' – 11" or just under the limit (typically six stories). Since going over that limit has heavy cost implications, buildings are either at six stories or much higher (12+), in order to justify the added cost. Raising the high-rise limit to be in accordance with the IBC limit would allow developers to add up to two more floors of housing in many projects (since, unlike Massachusetts, the IBC measures the height to the finish floor level rather than the roof). This increase follows accepted international standards, is consistent with most other states, and would add a much needed bump of units to the state's production goals.

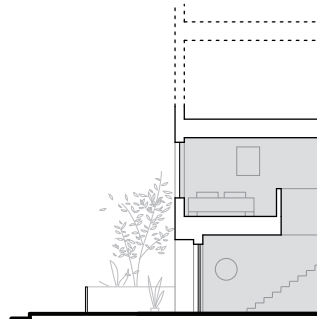

Permit Duplex Ground Floor Units

Under the Massachusetts Architectural Access Board, ground floor duplex units (two-level units), are made impossibly hard to permit due to elevator requirements, additional ingress requirements, and discrepancies in the code; as such they are few and far between. However, these two-level units are critical to expanding the stock of family-sized units, and making ground floor, street-facing units successful. Urbanistically, not every street needs or can support ground level retail, and residential units fronting on a street can activate a building frontage in a much more successful way than bike rooms, screened parking, or blank walls. Successful ground level units need a spatial buffer from the street, which can be in the form of vertical separation through stoops or porches, or having the units be duplex themselves, which put living spaces on the entry level and sleeping spaces above. Allowing these units will not sacrifice overall residential accessibility, and should be a priority for a state that needs more diverse housing types and in an economic climate where retail is rare and where we need more successful examples of urban infill housing frontage.

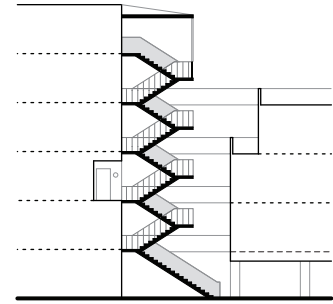

Allow Exterior Egress Stairs

In Greater Boston fire and building departments generally disallow the use of exterior egress stairs. However, exterior stairs are very common in other countries, including other cold and humid climates similar to New England, such as Japan and Northern Europe. They are also more common in single-stair buildings, such as those built under the Seattle code, because they offer a host of benefits.

Exterior stairwells, being adequately fire separated from the building and appropriately covered from the elements, can be just as safe or more safe than an interior protected stair, having less chance to be burdened by smoke accumulation. The stair has added benefits of reduced construction cost and access to more natural light and air. While the front door for most single-family homes fronts the elements, the entries for most multifamily dwelling units front a dark interior hallway. Exterior stairwells and walkways can provide borrowed natural light to the back-side of units, and oftentimes are a most pleasant atmosphere to arrive home to. Similarly when stairs are enjoyable spaces they are more likely to be used, which has numerous social and health benefits. These should be considered as an available option apart from the typical dark concrete cell we know today.

IV. Point Loaded Potentials

BUILDING MORE MID-RISE

In Greater Boston and beyond we have been building less mid-scale housing over time. In Boston, as a percent of all housing built, the share of buildings under 50 units has fallen from 90% before 1940 to 35% today. In the last two decades, of all multifamily buildings built in Greater Boston, 75% of units were in buildings with 50 or more units, while only 15% of units were in buildings with 10 to 50 units. A multitude of factors shapes the trend toward larger buildings, including increasing construction complexity, rising land prices and the need to scale development, higher inclusionary housing requirements on mid-scale buildings, and slower entitlement approvals processes. Permitting single-stair housing will not be a panacea, but it has the potential to be a surgical salve to increasing mid-rise housing across the region.

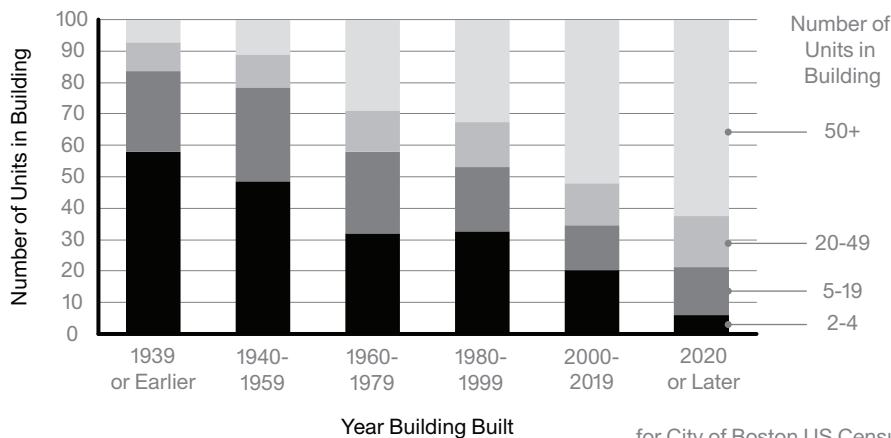

for City of Boston US Census Bureau, 2022. American Community Survey 5 Year Estimates

PABS FOR SMALL PLOTS

Of all parcels in Greater Boston, 76% (or 161,860 parcels) fall between 3,000 and 15,000 square feet in area. This represents the lower and upper limit of where PABs are feasible, and stops short of sites where existing two-stair development is already happening. While single-stair buildings can fit on even smaller parcels or provide wonderful aggregated designs on even the largest parcels, this report contends that the greatest benefit might be seen on the parcels too small for podium buildings, but large enough to host a meaningful amount of new units; it happens that these parcels in our region represent the majority of the urban fabric.

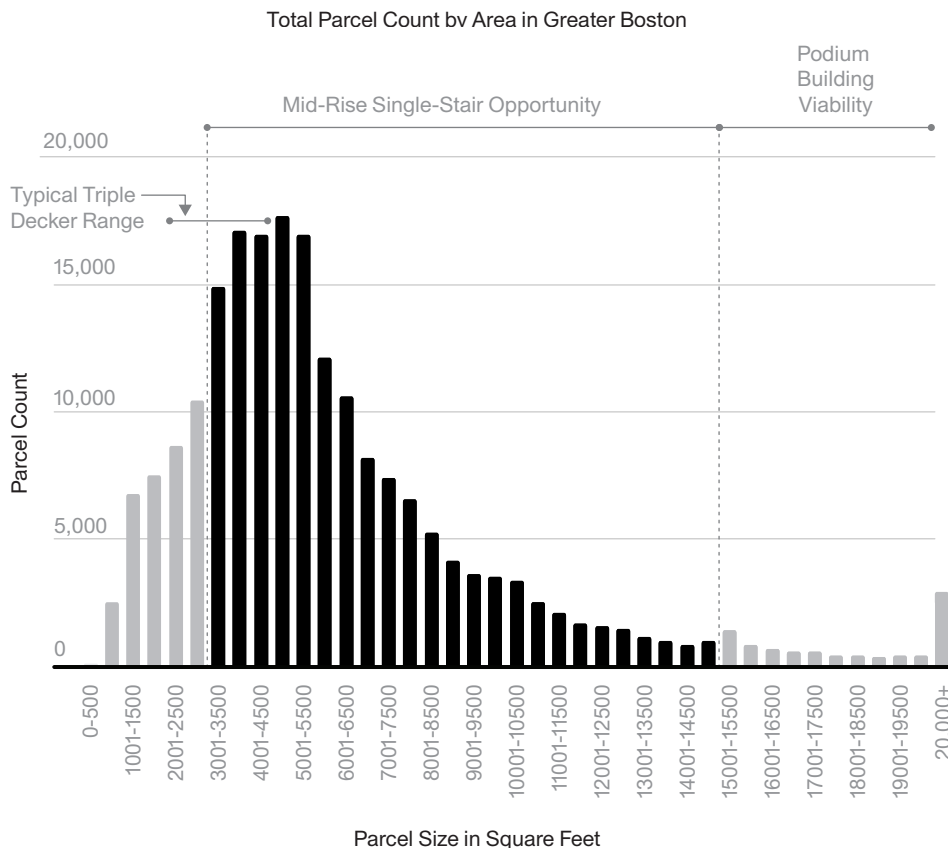

In order to look at sites prime for development among these 161,860 parcels, our study culled ones that are further than 0.75 miles from a rapid transit stop (a 15-minute walk) and sites that are already developed (by removing those with more than a floor-to-area ratio (FAR) of 0.1). We also removed dedicated open space, and oddly shaped or unbuildable parcels. The remaining parcels count 4,955, totalling 33,528,119 square feet. These are mostly parking lots; vacant, single-story retail; or other opportunity areas that are not at their best and highest use.

Of these sites our study divided them into three equal buckets by size and designed preliminary test fits of single-stair four to six story buildings. The smallest designs include both party-wall designs and smaller unit types; the next largest sites are ideal for one single-stair building with four units per floor; and the largest of sites can host multiple single-stair buildings aggregated together to form compositions of dozens of units. Mapping these test fits out, over the range of available parcels available in transit-oriented areas, could conceivably net upwards of 130,000 new homes.

The state has a housing target of creating 200,000 new homes by 2030. If only a small fraction of these units were built it would make a meaningful contribution to that goal, and would unleash a fresh mid-rise pattern of city building of a scale that Greater Boston was founded on, but in recent memory has faded away. In the past two decades the scale of podium housing built on post-industrial sites at the edges of Boston's traditional neighborhoods has not kept up with the demand for new

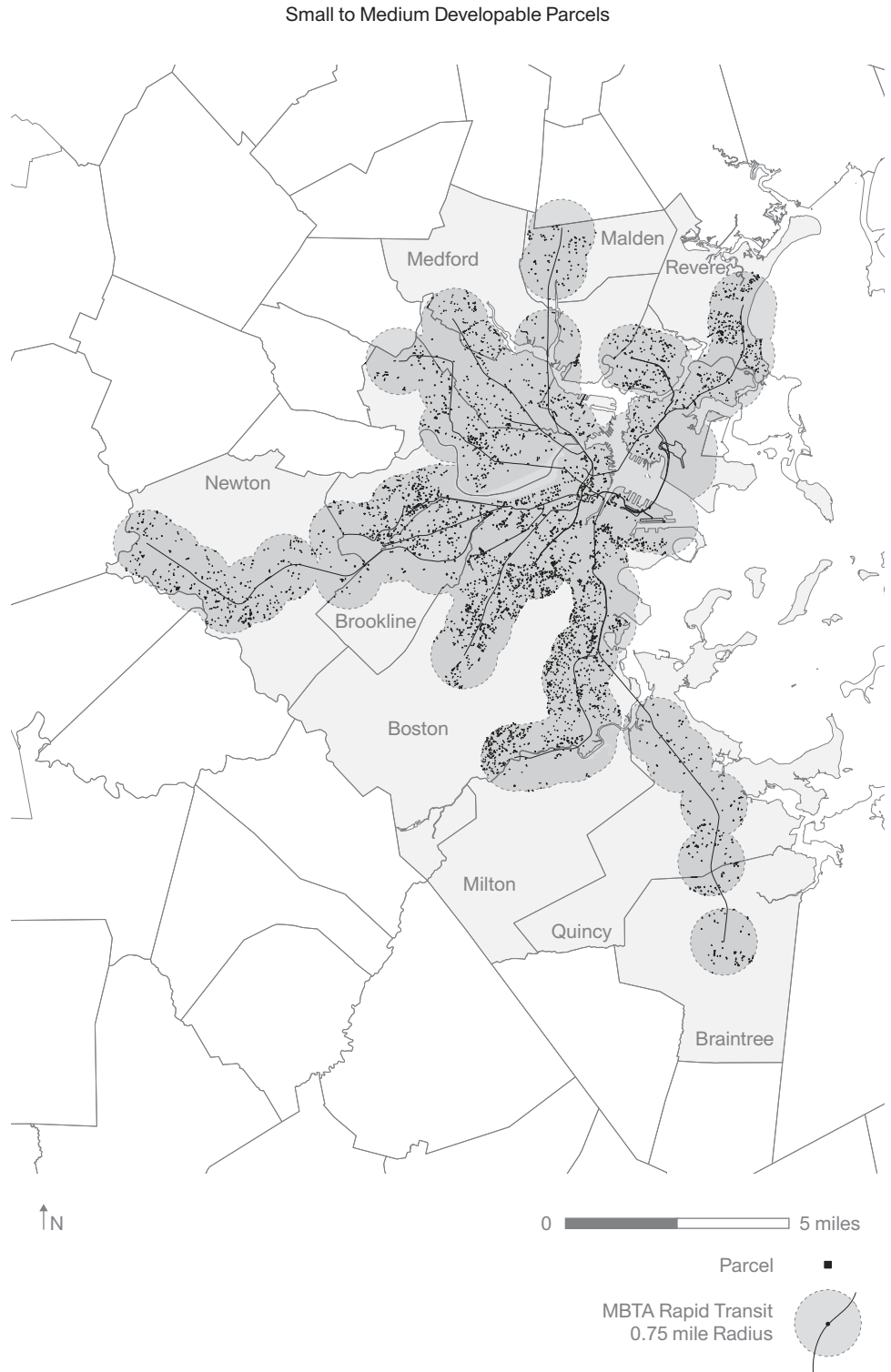

units. Further, they have failed fundamentally to create urban areas of character and vitality. Mid-rise point access block housing has several advantages from an urban design standpoint. The buildings typically fit on the smaller lots of existing urban residential neighborhoods, and when built as part of a larger new development, they create a more walkable neighborhood and when combined with larger residential buildings, provide a wider range of unit types and levels of affordability. They also make it easier to provide private outdoor space to each of the units. Overall, the effect is more housing on lots where it's needed, but also more robust neighborhoods, both socially and economically.

HOMES WE CAN BE PROUD OF

Successful housing projects stand the test of time to be recognized as models to follow. Yet, almost every architecturally significant housing project taught in design schools today is, for one reason or another, presently illegal to build in this state.¹⁶ The reasons range from reasonable (new accessibility and energy codes), to regressive (restrictive zoning and egress codes). This report is a call to change our building code, but also a call to action for architects everywhere to more meaningfully engage in the rules and regulations by which our designs are bound. Architecture and other built environment design disciplines have an on-the-ground experience with the technocratic and site specific constraints through which American buildings get funded, planned, built, occupied, and maintained. These insights often contrast against a global design

Parcel Shapes

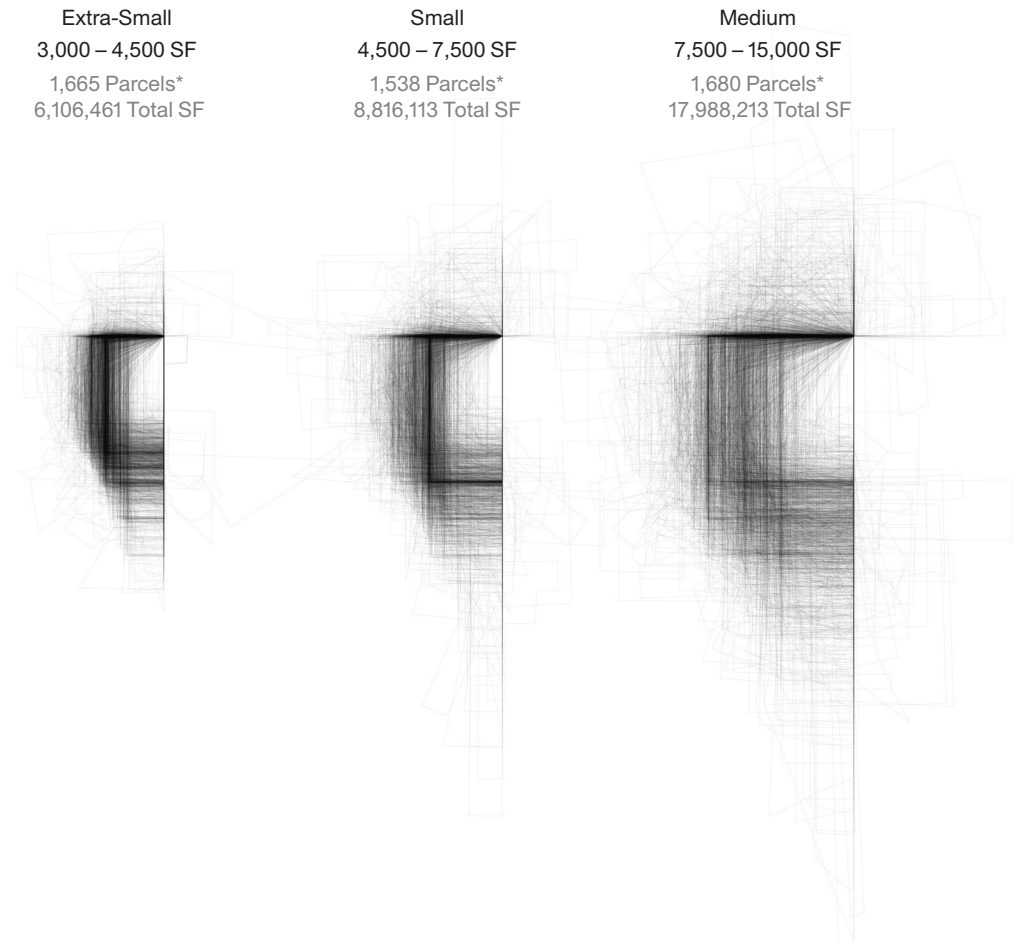

Most Average Parcels

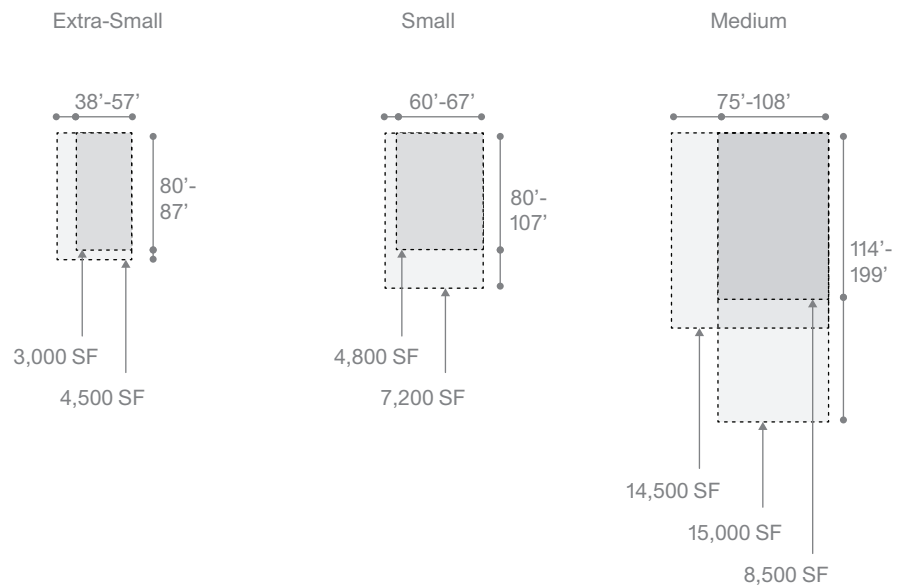

education and professional context where things are often done differently. Care should be taken to consider more meaningfully these differences, learn from them, and educate others. It should also be a call for policymakers and planners to learn more about the rules that constrain the physical design of housing and how best those rules should be adjusted with the times, which would also help ensure inclusionary zoning and other affordable housing incentives are feasible in light of design and construction limitations. Without such a cross-pollination, we have no hope of making meaningfully better buildings than the current combination of regulations and market forces decides to deliver, let alone crafting a fabric of housing that is more desirable to live in than old, tired patterns of car-centric and exclusive development.

Given the life safety issues at stake, updates to the building code must be driven by fact-based technical information. Typically, this area of expertise has been the purview of fire engineers and other safety experts, although it's also true that industry organizations who support their efforts propose updates and defend existing code definitions through the lens of their own interests.¹⁷

The housing crisis in Massachusetts has introduced other stakeholders to the conversation about building codes, and who has the final say about the priorities that should be considered. The MBTA Communities Zoning Law, which requires communities served by transit and commuter rail to amend their zoning to allow for higher density housing, has helped to make it clear that other regulations also need to be

(XS) Parcel
3,100 SF Parcel
2,300 SF Floor Plate
+/- 8 Units

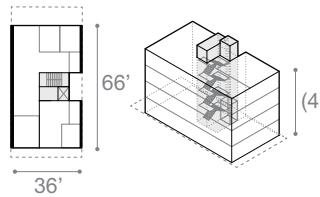

(XS) Parcel
4,500 SF Parcel
2,700 SF FP
+/- 15 Units

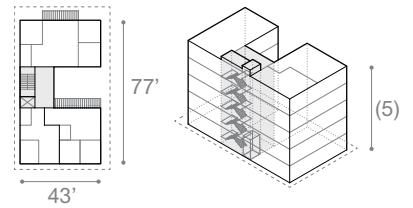

(S) Parcel
5,200 SF Parcel
3,600 SF FP
+/- 20 Units

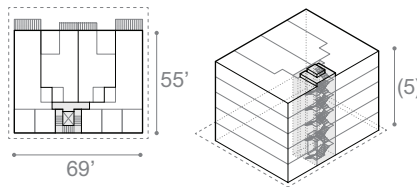

(S) Parcel
7,200 SF Parcel
4,000 SF FP
+/- 24 Units

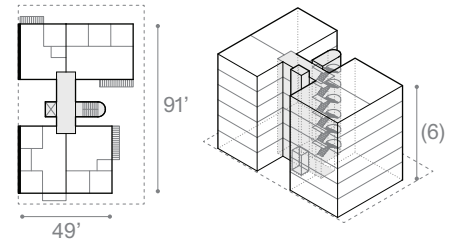

(M) Parcel
8,500 SF Parcel
2,200 + 2,600 SF FP
+/- 27 Units

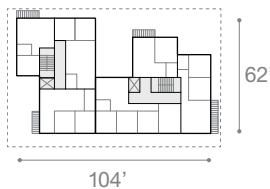

(M) Parcel
4,500 SF Parcel
4,300 (X3) SF FP
+/- 66 Units

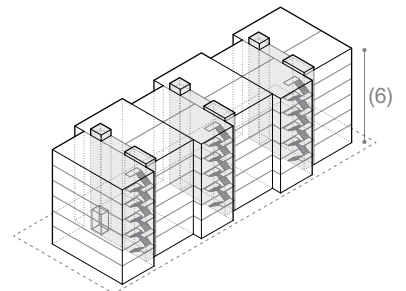
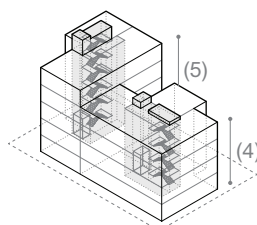
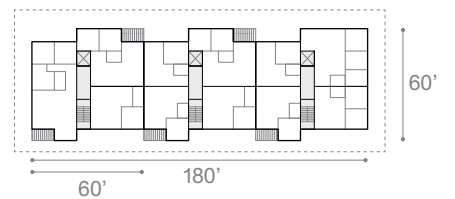

amended if right-sized residential projects are to be built within a reasonable walking distance from transit. It is within this context that both current and potential future regulations for single-stair residential buildings should be considered.

Importantly, most parcels within the watershed of transit are in areas within cities and towns that were planned and developed before the Second World War when speculative development was executed at a smaller scale using repeatable market-tested building types. An increase in the allowable height and number of units of single-stair residential buildings from three stories and 12 units to six stories and 24 units will help unlock these transit-oriented sites, while resulting in better residential units that are more conducive to a wider range of apartment types. As a result, impacts to housing production and the relative quality of the residential units that are delivered should be as much a priority when weighing the pros and cons of building code reform as the life safety issues that have dominated the discourse to date. This is not to say that safety should not be a central focus, but only that careful consideration should also be given to how best to mitigate risk while also considering social benefits related to the cost and type of housing that is possible to build.

This report and its recommendations comes from a team of architects, urban designers, planners, policy wonks, housing advocates, and researchers. It comes from folks living and working in the cities and towns most in need of new housing and frustrated by what they see as

artificial limits on the shape, scale, and cost of buildings possible to meet the needs of our communities. As we developed this report, fire chiefs, housing advocates, and others have been and continue debating this issue. Both across our Commonwealth and country and among our neighbors to the North in Canada, transparent, diverse, and fact-based conversations about the form and quality of housing should continue to be pursued. The language of the building code impacts everyone's lives, and its provisions should not be decided unilaterally by a limited set of perspectives of those with expertise in this arcane subject. All Massachusettsans should have a say in how to achieve the appropriate degree of safety in our buildings while also allowing for housing that meets other social needs. If the buildings we want to have are not possible to build today we shouldn't settle for less; we should instead keep working to design solutions that enable housing we all want to live in that is safe but also affordable, healthy, and beautiful.

Single-stair egress allows the implementation of PABs, which have been the bedrock architectural typology of mid-rise city-building for centuries. The benefits to this type of housing are numerous, and the downsides of not implementing it will be felt in the pocketbook and mindset of millions for generations—let's code for the scale of housing we need, and the layout of homes we want to live in, forever.





CITATIONS

- 1 These can include stair pressurization, additional mechanical ventilation, fire access elevator requirements, more advanced fire alarm requirements, additional egress markings, construction type limitations, elevator lobby enlargements, and more costly exterior cladding options.
- 2 We use this term here and elsewhere to describe the combined cities (including Boston) classified as rapid transit communities under the MBTA Communities Act. This includes Boston, Braintree, Brookline, Cambridge, Chelsea, Everett, Malden, Medford, Milton, Newton, Quincy, Revere, and Somerville.
- 3 Also key are various other regional entitlement thresholds. Including the Inclusionary Development Policy (IDP) for the city of Boston (which requires 13 – 20% of the units to be affordable), the new stretch building code (which requires buildings over 12,000 square feet to meet Passive House standards), and the small project article 80 review process for the city of Boston (kicks in for projects over 15,000 gross square feet, or about 15 units).
- 4 \$200,000 is an average cost for a CMU-block stairway with all the necessary features in a typical US submarket. \$500,000 represents the floor area multiplied by a cost per square foot of \$350, which is common for new residential construction in Greater Boston.
- 5 The Greater Boston Housing Report Card 2023, Aja Kennedy et al. The Boston Foundation, 2023.
- 6 Vermont and Georgia do not adopt the IBC for critical chapters on means of egress, and instead adopt parts of the National Fire Prevention Association (NFPA) model building code, which allows for single egress multifamily buildings to be four stories tall with four units per floor (per NFPA 101, 20.2.4.6).
- 7 Section 521 of the Code of Massachusetts Regulations (CMR), which is under the purview of the Architectural Access Board
- 8 The practical acceptance in Switzerland is 75m to 100m.
- 9 Data collection quality and validity varies from country to country. Some countries collect only data on the worst fires, while others collect on all fires. Definitions of terms are also not fully standardized across these studies, and less economically advanced countries have less quality data to compare.
- 10 U.S. Experience with Sprinklers, Tucker McGree. National Fire Protection Association, April 2024.
- 11 McGree, 2024.
- 12 McGree, 2024.
- 13 NFIRS 5.0, Automatic Extinguishing System Data for Nonconfined Multifamily Residential Building Fires (2005 – 2007)
- 14 Two such contests include Decoding Density from Urbanarium <https://urbanarium.org/decoding-density#winner-press-release> and Buildner Architecture Competitions <https://architecturecompetitions.com/pointaccessblock/>.
- 15 Center for Building in North America
- 16 To name a few: 59 Dwellings at Neppert Gardens, the Barbican, Buchgrindel II, Byker Regeneration, Full Stop & Comma Housing, Hardegg, Jeanne Hachette Complex, Justus Van Effen Complex, Kitagata, Nexus World, and Unité d’Habitation
- 17 As evidenced in the evolution of our elevator requirements: “The American Elevator Explains Why Housing Costs Have Skyrocketed,” Stephen Jacob Smith. *The New York Times*, July 8, 2024.

Terms

Common Path of Travel

The distance one must travel to get from the furthest point in a room to the point of access to another means of egress

Double-Loaded

An architectural floor plan term that describes units arrayed off of a single hallway. Also used to describe parking layouts with a central aisle, it is the most efficient way to arrange units in a building when two staircases are prescribed, and thus is the de facto method of mid-rise housing production in North America. This type is often called “hotel” housing by the rest of the world, where two stairs are only required for transient housing types. Conversely, single-loaded refers to units arranged along one side of the linear circulation hall, and point-loaded would be when units are arranged around a nodal circulation center.

Dwelling Unit

A policy and code classification for a residential home within a multifamily building. It can be a single story or multistory, and can be through ownership (condo or cooperative) or through rental (apartment).

High Rise / Mid-Rise

A code classification often demarcated as the point at which fire rescue service ladders from the ground can no longer reach the highest occupiable window. This is defined in the IBC as 75 feet above grade plane, but in Massachusetts has been amended to be 70 feet. Also an urban and architectural classification for buildings: 1 – 3 stories are Low-Rise, 3 – 7 are Mid-Rise, and above 7 are High-Rise.

Net / Gross Floor Area

The efficiency of a building is measured by dividing its net floor area, or area that is rentable or salable, by its gross floor area, or total area of the building. This efficiency factor is highly scrutinized during early design and development stages, and for residential construction ranges from 75 – 90%, most typically at around 80 – 85%, with the higher the number meaning a more profitable and “efficient” building.

Point Access Block (PAB)

A single-stair housing category. Named because rather than loading off of a corridor (required when two stairs need to be connected), one loads from a singular central core (point). The term refers to single buildings but also larger complexes composed of multiple buildings next to each other separated by party fire walls.

Podium Building / Five-Over-One

A light wood-frame (combustible construction) building on top of a steel or concrete (noncombustible) building below. Generally the former is four to six levels, and is of construction types III, IV, or V, and composes the housing element. The latter is generally one or two levels, is of types I or II construction, and comprises parking, retail, lobbies, mechanical services, back of house rooms, and sometimes ground floor units.

Maximum Exit Access

The longest allowed distance one needs to travel from the furthest point in a room to reach the point of entering a rated exit enclosure (stair). Currently 250' in a sprinklered multifamily building; 75' in this proposal for a single-exit sprinklered building.

Means of Egress / Escape

Egress generally refers to a rated exit enclosed stair or hallway that is an uninterrupted path from entry until one reaches a public way. Escape refers to other methods of getting out of a building in an emergency, such as through a window or being rescued, but is not the designed method of exit during a fire event.

RESOURCES

- About Here. 2022. “The One Rule Holding Back Housing and Nice Apartments” (video). www.youtube.com/watch?v=iRdwXQb7CfM
- Armlovich, Alex. 2024. “Exit Strategy.” *Architectural Record* 212 (5): 31 – 33. www.architecturalrecord.com/articles/16880-exit-strategy-the-case-for-single-stair-egress
- Chen, Kevin, and Biswadeep Ghosh. 2024. Single Egress Stair Building Designs: Policy and Technical Options Report. Jensen Hughes Canada. www2.gov.bc.ca/assets/gov/farming-natural-resources-and-industry/construction-industry/building-codes-and-standards/reports/report_for_single_egress_stair_designs.pdf
- Eliason, Michael. January 2022. Unlocking Livable, Resilient, Decarbonized Housing with Point Access Blocks. Larch Lab. www.larchlab.com/wp-content/uploads/2022/01/Eliason_CoV-Point-Access-Blocks-report_v1.2.pdf
- Gates, Blandford, and Paul Sandori. 1984. *Fire Safety and the Design of Apartments*. Canada Mortgage and Housing Corporation. assets.cmhc-schl.gc.ca/sf/project/archive/research/ca1_mh_84f38.pdf
- Grabar, Henry. December 2021. “The Single-Staircase Radicals Have a Good Point.” *Slate*. slate.com/business/2021/12/staircases-floor-plan-twitterhousing-Apartments.html
- Housing Forward Virginia. 2023. “The Single-Stair Case: Rethinking Building Codes to Legalize Affordability - xChats” (video). www.youtube.com/watch?v=r9cp29fBAwg
- Jursnik, Sean (ed.). October 2023. *Expanding Colorado Housing Options: How to Create Safe, Small Apartment Buildings*. SAR+ Architects.
- Justus, Andrew. December 2022. How to Build More Family-Sized Apartments. Niskanen Center. www.niskanencenter.org/how-to-build-morefamily-Sized-apartments
- Kemper, Nicolas. March 1, 2022. “Cancel the Corridor.” *New York Review of Architecture*. nyra.nyc/articles/cancel-the-corridor
- Kennedy, Aja, Peter Ciurczak, Luc Schuster, Penn Loh, Chelsea Gao, and Johnny Shively. 2023. *The Greater Boston Housing Report Card 2023*. The Boston Foundation. www.tbf.org/-/media/tbf/reports-and-covers/2023/gbhrc2023-full-report.pdf
- Love, Timothy. 2004. “Double Loaded: Everyday Architecture and Windows for Improvement.” *Harvard Design Magazine* Fall 2004/Winter 2005, Number 21.
- McGree, Tucker. April 2024. U.S. Experience with Sprinklers. National Fire Protection Association. www.ctif.org/sites/default/files/2022-08/CTIF_Report27_ESG_0.pdf
- National Fire Incident Reporting System (website). Federal Emergency Management Agency. www.usfa.fema.gov/nfirs/
- PUBLIC Architecture. 2023. *Single-Stair Residential Buildings*. BC Housing’s Building Excellence Research & Education Grants and the City of Vancouver. www.bchousing.org/sites/default/files/media/documents/Single-Stair-Residential-Buildings-PUBLIC.pdf
- Shafaieh, Charles. 2023. “Creative Corridors.” *The State of Housing Design*. Joint Center for Housing Studies of Harvard University.
- Smith, Stephen, and Eduardo Mendoza. 2024. “Point Access Block Building Design: Options for Building More Single-Stair Apartment Buildings in North America.” *Cityscape: A Journal of Policy Development and Research* 26, no. 1 (2024): 431 – 447.
- Smith, Stephen. July 8, 2024. “The American Elevator Explains Why Housing Costs Have Skyrocketed.” *The New York Times*. www.nytimes.com/2024/07/08/opinion/elevator-construction-regulation-labor-immigration.html
- Speckert, Conrad. 2022. Second Egress: Building a Code Change (website). <https://secondegress.ca>
- Speckert, Conrad. February 17, 2023. “The Curse of the Double Egress.” *Urban Progress*. urbanprogressmag.com/article/double-egress-stairway-exit-double-loaded-corridors-curse
- Wallasch, Karl, and Boris Stock. September 21, 2009. “Karl Wallasch and Boris Stock on Germany’s regulatory approach to single-stair high-rise buildings.” 2009. Building. www.building.co.uk/karl-wallasch-and-boris-stock-on-germanys-regulatory-approach-to-single-stair-high-rise-buildings/3149160.article

