



CITY OF SOMERVILLE
Commonwealth of Massachusetts
93 Highland Avenue
Somerville, MA 02143
(617) 625-6600

BUSINESS LICENSE APPLICATION - Grant of Location

File #: 18-021373

License #: BL20-000134

Address: 75 MYRTLE ST

Licensee: Matthew Pricco Network Building + Consulting

DBA Name: ExteNet Systems, Inc.

Business Ownership Type: Corporation

Legal Name of Entity: ExteNet Systems, Inc.

Owners/Officers: James A. Hyde, H. Anthony Lehv, Daniel L. Timm,

License Information:

Grant of location issued to: ExteNet Systems, Inc.

Describe the reason for the work, and the intended beneficiaries: Underground connections to small cell wireless facility at 75 Myrtle St. The facility will improve wireless communications services for residents, businesses, and visitors in the vicinity.

Insert here the same detailed description of the work as appears in the attached Grant of Location

Order: Pearl St: - Starting at existing manhole EMH #4550 placing (1) 2" PVC Conduit for Power Feed and (1) 2" PVC Conduit for Fiber Feed approximately 31' to Proposed Handhole 4' West/Northwest of CRAN_RT CB_009_05 Node Location. - Proposed 12" x 24" Handhole to service CRAN_RT CB_009_05 Node Location. - Starting at Proposed Handhole placing (1) 3" PVC Conduit for Power & Fiber Feed approximately 4' to CRAN_RT CB_009_05 Node Location.

Approval Conditions:

Approved By:

Karla Cuarezma, Approved

Malik Drayton, Approved with Conditions

APPROVAL CONDITION: MD20200913: Contractor shall take all necessary precautions to avoid damaging any tree or tree part with equipment.

APPROVAL CONDITION: MD20200913: All nearby street tree(s) shall be protected prior to and during all construction activities using TREE BOX or TREE WRAPS. . TREE BOX shall be constructed from 2 in. x 4 in. lumber creating a box around the border of the tree pit with 2 in. x 4 in. lumber standing straight up at the corners and wrapped with orange snow fence. Detail attached. . TREE WRAPS (TREE TRUNK WRAPPING PROTECTION LUMBER) shall consist of 2 in. x 4 in. and 8 ft. height lumber wired together in close spacing with zip ties or 16 gauge galvanized steel wire to form a protective enclosure around tree trunks. Use burlap to separate the wood from the bark if necessary to prevent wood from scraping or bruising bark. Do not use staples or puncture the trunk in any way.

APPROVAL CONDITION: MD20200913: Any tree roots less than two (2) inches in diameter that cannot be

avoided during construction shall be carefully and cleanly cut with a clean pair of pruning shears or loppers. Roots are to be cut back flush with the edge of the trench. If any tree roots greater than two (2) inches in diameter are encountered, stop work immediately and contact the City Urban Forester. Any and all pruning of roots greater than 2 inches in diameter must be completed under the supervision of the City Urban Forester.

Mark Lawhorne, Approved

John J. Long, Approved



CITY OF SOMERVILLE, MASSACHUSETTS
CITY CLERK'S OFFICE
JOSEPH A. CURTATONE
MAYOR

JOHN J. LONG
CITY CLERK

September 30, 2020

NOTICE OF PUBLIC HEARING

You are hereby notified that the Somerville City Council will hold a Public Hearing on the following Petition. You are receiving this Notice because the Petitioner has reported that you own property that abuts the work that is being proposed. You and other members of the public are invited to attend and be heard at this Hearing.

Because of Governor Baker's and Mayor Curtatone's recent orders limiting the number of people that may gather in one place, **this meeting of the City Council will be conducted via remote participation, online in a webinar hosted on the GoToWebinar platform.**

You have two ways to be heard at this meeting:

1. To attend and be heard, enter the link exactly as it appears below into your internet browser any time before the meeting. You will then be asked to register for the meeting. After registering, you will receive an email with instructions to join the webinar when it starts.
2. If you are unable to attend but wish to be heard, you may send written comments by US mail to the City Clerk at the address below, or by email to cityclerk@somervillema.gov. Your comments must arrive no later than 12 Noon on the day of the Hearing, in order to be sure they are conveyed to the Council.

PETITION: Extenet seeks a Grant of Location to install a total of 35 feet of conduit in Pearl Street as follows: Starting from manhole #4550 to a proposed handhole, then continuing 4 feet to a small wireless facility node at the intersection of Florence Street and Pearl Street.

PLACE: <https://attendee.gotowebinar.com/register/4410650622739523596>.

TIME: Thursday, October 8, 2020, at 7:00 PM.

PURPOSE: The work is necessary to provide service to a small wireless facility.

CONCRETE STREETLIGHT

ALL FIELD DATA ACQUIRED USING TOTAL STATION SURVEY EQUIPMENT

GENERAL NOTES

- 1. THE LOCATIONS OF EXISTING UNDERGROUND UTILITIES ARE SHOWN IN AN APPROXIMATE WAY ONLY AND HAVE NOT BEEN VERIFIED BY THE CONTRACTOR. THE CONTRACTOR SHALL DETERMINE THE EXACT LOCATION OF ALL EXISTING UTILITIES BEFORE COMMENCING WORK, AND SHALL BE FULLY RESPONSIBLE FOR ANY AND ALL DAMAGE TO EXISTING UTILITIES. THE CONTRACTOR SHALL BE RESPONSIBLE TO EXACTLY LOCATE AND PRESERVE ANY AND ALL UNDERGROUND UTILITIES.
- 2. WHERE AN EXISTING UTILITY IS FOUND TO INTERFERE WITH THE PROPOSED WORK, THE LOCATION, ELEVATION AND SIZE OF THE UTILITY SHALL BE DOCUMENTED AND INFORMATION FURNISHED TO THE ENGINEER FOR RESOLUTION OF THE CONFLICT.
- 3. THE CONTRACTOR SHOULD MAINTAIN A SEPARATION OF 18 INCHES MIN. WHEN CROSSING EXISTING WATER PIPES.
- 4. THE CONTRACTOR SHALL MAKE ALL ARRANGEMENTS FOR THE ALTERATION AND ADJUSTMENT OF GAS, ELECTRIC, TELEPHONE AND ANY OTHER PRIVATE UTILITIES BY THE UTILITY COMPANY.
- 5. THE CONTRACTOR SHALL NOT DISTURB PUBLIC TREES AND SHRUBS.
- 6. AREAS OUTSIDE THE LIMITS OF PROPOSED WORK DISTURBED BY THE CONTRACTOR SHALL BE RESTORED TO ORIGINAL CONDITION AT NO EXPENSE TO THE OWNER.
- 7. THE CONTRACTOR SHALL BE RESPONSIBLE FOR PLACING AND MAINTAINING TEMPORARY RESURFACING AND/OR PLATING FOR ALL EXCAVATIONS IN PAVED STREETS, AND SIDEWALKS UNTIL PERMANENT RESURFACING IS COMPLETE.
- 8. JOINTS BETWEEN NEW BITUMINOUS CONCRETE ROADWAY PAVEMENT AND EXISTING PAVEMENT SHALL BE SEALED WITH BITUMEN AND BACK SANDED.
- 9. THE CONTRACTOR SHALL PROTECT AND SUPPORT ALL EXISTING UTILITY LINES THAT BECOME EXPOSED DUE TO EXCAVATION REQUIRED TO INSTALL THE PROPOSED CONDUIT.
- 10. THE CONTRACTOR SHALL REPLACE ALL DISTURBED TRAFFIC SIGNAL LOOP DETECTORS GOOD WORKING CONDITION AS REQUIRED BY THE LATEST STANDARDS OF THE MANUFACTURER OF EQUIPMENT.
- 11. THE CONTRACTOR SHALL BE RESPONSIBLE FOR OBTAINING AND VERIFYING THEIR EXACT LOCATION ARE NOT GUARANTEED.
- 12. THE CONTRACTOR SHALL REPLACE ALL PAVEMENT MARKINGS IN THEIR ENTIRETY THAT HAVE BEEN DAMAGED BY TRENCH EXCAVATION OR OPERATIONS OF THE CONTRACTOR WITH SIMILAR COLOR AND SIZE THERMOPLASTIC MARKINGS.
 - * - ITEMS SHOWN ON UTILITY RECORDS.
 - * - ITEMS FOUND IN FIELD.
 - * - BUT NOT IN UTILITY RECORDS.

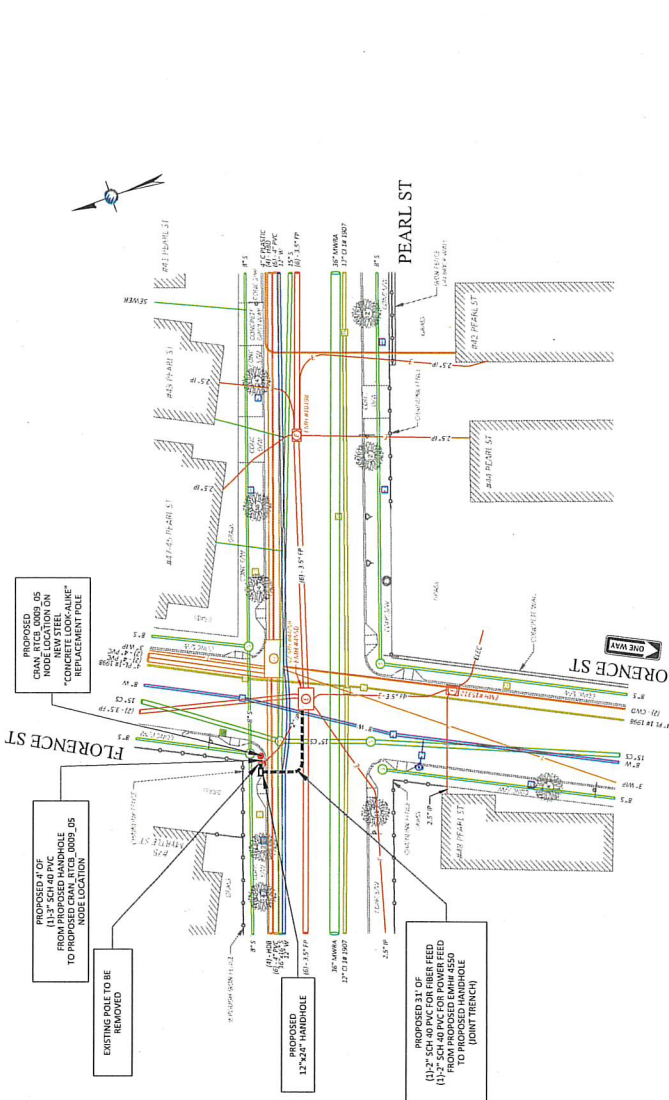

NOTE
EXISTING UTILITIES SHOWN ARE APPROXIMATE AND NOT WARRANTED TO BE CORRECT. THE CONTRACTOR SHALL VERIFY THE EXACT LOCATION OF ALL EXISTING UTILITIES PRIOR TO BEGINNING ANY EXCAVATION.



CALL BEFORE YOU DIG
UNDERGROUND SERVICE ALERT
72-HOURS NOTICE REQUIRED
TOLL FREE: 888-888-6848



PREPARED BY: 21. Delmar Rd
WWW.PIKTELECOM.COM
1-800-543-3554

PREPARED FOR: extelnet

KEY #	DESCRIPTION	DATE

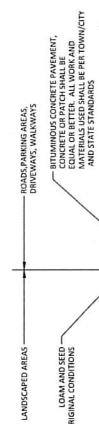

GENERAL POWER TRENCH DETAIL
N.T.S.

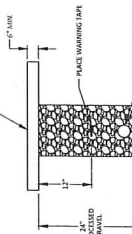

PROPOSED DUCT CONFIGURATION
BANK INSTALLATION DETAIL
N.T.S.

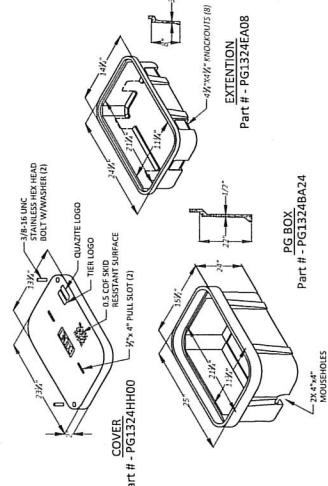

PG-STYLE POLYMER CONCRETE (STACKABLE) ASSEMBLY
N.T.S.

75 Myrtle St

List of Abutters for Grant of Location

Assessor Parcel	Property Address	Abutter Name	Abutter Mailing Address
105-A-1	69 Myrtle St Somerville, MA	AZEREDO MARIA S & JOSEPH P	61 ROCKVALE ROAD TEWKSBURY, MA 01876.
91-G-11	59 Pearl St Somerville, MA	DIRENZO ROCCO TRUSTEE R & I REALTY TRUST	PO BOX 45592 SOMERVILLE, MA
104-D-29	70 Myrtle St Somerville, MA	POUSLAND MARIA L	70 MYRTLE ST SOMERVILLE, MA 02145
105-A-2	52 Pearl St Somerville, MA	POWERS FRANCIS J S/O CAROL A POWERS TRUSTEE	52 PEARL ST SOMERVILLE, MA 02145
91-F-4	75 Myrtle St Somerville, MA	SOMERVILLE HOUSING AUTH	30 MEMORIAL RD SOMERVILLE, MA 02145