

# brownrudnick

Edward D. Pare, Jr., Esq.  
direct dial: 401-276-2639  
epare@brownrudnick.com

September 16, 2019

## VIA FEDERAL EXPRESS

Jessica Fosbrook  
Director of Engineering  
Somerville Engineering Department  
City of Somerville  
Department of Public Works  
1 Franey Rd.  
Somerville, MA 02145

**Re: Request for Approval of Sixteen (16) Eligible Facilities Requests to Modify Transmission Equipment at Existing Base Stations within the Public Rights-of-Way Located Near the Following Addresses in Somerville, MA**

**65 Main Street - Site 01  
509 Broadway - Site 03  
257 Cedar Street - Site 05  
99 Brastow Avenue - Site 06  
66 Belmont Street - Site 07  
231 Lowell Street - Site 09  
Webster Street - Site 15  
4 Central Street - Site 17  
79 Derby Street - Site 22  
1 MacArthur Street - Site 23  
1 Benedict Street - Site 24  
41 Inner Belt Road - Site 26  
1 Flint Street - Site 37  
11 Hathorn Street - Site 38  
Beacon Street, Near Sacramento Street - Site 70  
Beacon Street, Near Park Street - Site 71**

Dear Ms. Fosbrook Council:

On behalf of Crown Castle NG East LLC ("Crown Castle") and while reserving all rights, we submit this Eligible Facilities Request application to add, remove, modify, or replace Transmission Equipment<sup>1</sup> at existing Base Stations located near the above referenced addresses in Somerville, MA. We seek approval of the site modifications as depicted on the attached plans (the "Plans") as Eligible

---

<sup>1</sup> The FCC has defined "Transmission Equipment" as "any equipment that facilitates transmission for any Commission-licensed or authorized wireless communication service, including, but not limited to, radio transceivers, antennas and other relevant equipment associated with and necessary to their operation, including coaxial or fiber-optic cable, and regular and back-up power supply. This definition includes equipment used in any technological configuration associated with any Commission-authorized wireless transmission, licensed or unlicensed, terrestrial or satellite, including commercial mobile, private mobile, broadcast and public safety services, as well as fixed wireless services such as microwave backhaul or fixed broadband." In the matter of Acceleration of Broadband Deployment By Improving Wireless Facilities Siting Policies, Report and Order, FCC 14-153, WT Docket No. 13-238, ¶ 160 (FCC Oct. 21, 2014) ("Wireless Infrastructure Order"); 47 C.F.R. § 1.140001(b)(8)



Facilities Requests pursuant to the Section 6409 of the federal Middle Class Tax Relief and Job Creation Act of 2012, commonly known as the "Spectrum Act" (codified at 47 U.S.C. § 1455, copy attached), the associated regulations promulgated by the Federal Communications Commission ("FCC"), (47 C.F.R. 1.40001, the "Regulations", copy attached) interpreting the Spectrum Act and Section 4 of the City of Somerville's Standards for Small Cell Wireless Facility Placement in Public Right-of-Way (the "Standards", copy attached). Please note that capitalized terms not otherwise defined herein shall have the respective meanings set forth in the Spectrum Act and the Regulations.

Crown Castle's request is governed by Section 6409 of the Spectrum Act which provides that local governments **"may not deny, and shall approve, any eligible facilities request for a modification of an existing wireless tower or base station that does not substantially change the physical dimensions of such tower or base station [emphasis added]"**. Under Section 6409(a)(2)(A)-(C), an Eligible Facilities Request is any request to modify a Tower or Base Station that involves "collocation of new", or "removal," or "replacement" of existing Transmission Equipment.

Additionally, Section 4 of the Standards provides: "Collocation, modification or replacement of a wireless facility shall be approved by the Somerville Engineering Department if it does not substantially change the physical dimensions of the tower or base station within the meaning of 47 U.S.C. § 1455(a). Notwithstanding any other provision of these standards, the City may not deny, and shall approve, applications for eligible facilities requests pursuant to 47 U.S.C. § 1455(a), within sixty (60) days according to the procedures established under 47 CFR 1.40001(c)."

These Eligible Facilities Requests involve an effort to collocate, remove, modify, or replace Transmission Equipment at Existing Base Stations within public rights of way. The Existing Base Stations in this application are utility poles which presently contains Transmission Equipment installed by Crown Castle. Pursuant to these Eligible Facilities Requests, Crown Castle proposes to replace the existing 51" high by 14" wide equipment shrouds with new 70" high by 23.6" wide equipment shrouds; and, (b) the existing 48" high by 8"Ø antennas with new 48" high by 14.6" Ø antennas. We note the antenna on Site 05 located near 257 Cedar Street is a side mounted 24" high by 8" Ø antenna being replaced by a 24" high 14.6" Ø antenna.

Pursuant to the Spectrum Act and the Regulations, federal law preempts many of the permit application requirements that state and local authorities have required from an applicant and provides for a limited, administrative review of Eligible Facilities Requests. These Eligible Facilities Requests involve an effort to collocate Transmission Equipment on an Existing Structure used by an FCC licensed wireless carrier. Crown Castle seeks administrative approval of its Eligible Facilities Requests for the proposed modifications which do not Substantially Change the physical dimensions of the Base Station pursuant to Section 6409 of the Spectrum Act and the Standards.

As you may know, the FCC promulgated the Regulations interpreting and implementing the provisions of the Spectrum Act. The Regulations define "Substantial Change" as modifications to a Tower or Base Station that meet any of the following six criteria. Crown Castle has provided its response to each of the criteria below in bold:



1. The modifications to the Transmission Equipment do not increase the height of the Base Station by more than 10 percent (10%) or ten (10) feet, whichever is greater.

**The modifications to the Base Station will not increase the height of the Base Station by more than an inch or two, thus, less than ten (10) feet higher than the existing Base Station.**

2. The modifications to the shroud do not protrude from the edge of the Base Station by more than six (6) feet.

**After the modifications, the shroud, with the 7" mounting bracket, will protrude from the edge of the Base Station by approximately 28", thus, less than six (6) feet. As noted above, Site 05 located near 257 Cedar Street is side mounted and the arm holding the antenna will not extend more than 36" from the pole.**

3. The modifications to the Transmission Equipment do not involve the installation of more than the standard number of equipment cabinets for the technology involved, not to exceed four.

**The modifications do not involve the installation of any new equipment cabinets, thus, fewer than four.**

4. The modifications to the Transmission Equipment do not entail any excavation or equipment placement outside the Base Station Site.

**The modifications do not entail any excavation or equipment placed outside the Base Station Site.**

5. The modifications to the Transmission Equipment do not defeat any existing concealed or stealth-design.

**The modifications do not defeat any existing concealment elements. The equipment and antennas are located within stealth enclosures.**

6. The modifications to the Transmission Equipment comply with prior conditions of approval of the Base Station, unless the non-compliance is due to an increase in height, increase in width, addition of equipment cabinets, or new excavation that does not exceed the corresponding "substantial change" thresholds in numbers 1-4.

**The modifications do not violate any prior conditions of approval that are not due to the increase in height, width, addition of equipment cabinets or new excavation outside the Base Station Site.**



Additionally, pursuant to Section 1.40001(c)(1) of the Regulations, "when an applicant asserts in writing that a request for a modification is covered by this section, a State or local government may require the applicant to provide documentation or information only to the extent reasonably related to determining whether the request meets the requirements of this section." The Regulations provide that applicants are not required to justify a need for the facility. Further, the Regulations and Standards also require that approvals must be granted for eligible facilities requests within 60 days of the date that the application is submitted. As with the Existing Base Stations, the modifications will comply with all applicable laws and regulations, including the FCC's radio frequency emissions standards.

Under the Regulations and Standards, the City of Somerville must act upon these Eligible Facilities Requests within sixty (60) days from its submission or they will be deemed granted. If the City of Somerville contends that this Eligible Facilities Request is not complete, it must notify Crown Castle in writing within thirty days from its submission. In the written notification, the City of Somerville must "clearly and specifically delineate the missing information" as provided in the Regulations.

Crown Castle respectfully asserts, and we are confident that you will agree, that the modifications to the Existing Base Stations do not Substantially Change the dimensions of the Base Stations.

Please do not hesitate to contact me with any questions or if further information is necessary.

Respectfully,

**BROWN RUDNICK LLP**

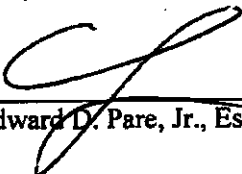
  
Edward D. Pare, Jr., Esq.

Attachments: Plans  
Section 6409 of the Spectrum Act  
FCC Regulations  
Somerville Standards  
Prior Approvals

cc: Frank Wright, Esq., City Solicitor (via email only, w/o attachments)  
David Shapiro, Esq., Assistant City Solicitor (via email only, w/o attachments)  
Joseph Shannon, Crown Castle (via email only, w/o attachments)



LATITUDE: 42.387171°  
LONGITUDE: -71.079446°



APPROVALS		
SIGNER	SIGNATURE	DATE
SPRINT CONSTRUCTION MANAGER		
SPRINT OPERATIONS MANAGER		
SPRINT RF ENGINEER		
LANDLORD		

**SPRINT BOSTON**  
**NODE: BS90XSG91**  
**PROPOSED DISTRIBUTED ANTENNA SYSTEM (DAS) NODE**  
 SOMERVILLE, MA 02145  
 MIDDLESEX COUNTY



Know what's below.  
Call before you dig.

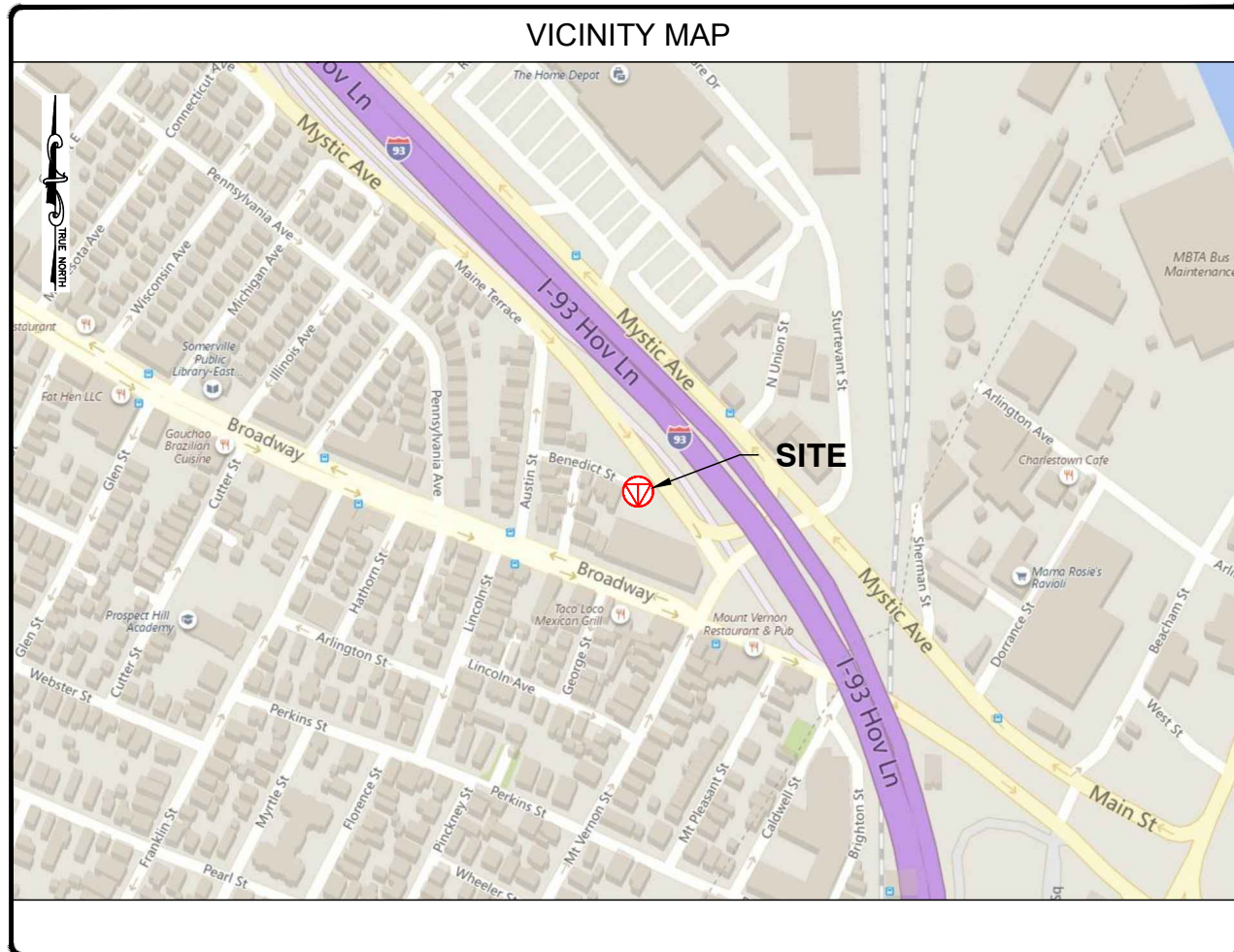

ENGINEERING FIRM

APPLICANT

SITE INFORMATION

DESIGN RECORD

PROFESSIONAL STAMP

ENGINEER

SHEET TITLE

SHEET NUMBER

BS90XSG91  
ODAS\_2D-24 / 406411  
1 BENEDICT STREET  
SOMERVILLE, MA 02145  
MIDDLESEX COUNTY

REVISIONS

REV	DATE	DESCRIPTION	BY
1	09/06/19	FINAL	DRG
0	07/27/18	PRELIMINARY	DRG



KRUPAKARAN KOLANDAIVELU, P.E.  
MA PROFESSIONAL ENGINEER LIC. #50019

TITLE SHEET

SHEET  
**01 OF 07**

PROJECT INFORMATION	
PROJECT NAME:	SPRINT BOSTON
NODE:	BS90XSG91
CROWN ID:	ODAS_2D-24 / 406411
NB+C ES PROJECT NUMBER:	100154-1014
JURISDICTION:	CITY OF SOMERVILLE
CROWN CASTLE PROJECT MANAGER:	SOPHIA BUCKLEY 67 SHARP STREET, UNIT 5 HINGHAM, MA 02043 (339) 205-7023
ELECTRIC COMPANY:	EVERSOURCE
TELEPHONE COMPANY:	VERIZON

CODE COMPLIANCE	
ALL WORK AND MATERIALS SHALL BE PERFORMED AND INSTALLED IN ACCORDANCE WITH THE CURRENT EDITIONS OF THE FOLLOWING CODES AS ADOPTED BY THE LOCAL GOVERNING AUTHORITIES. NOTHING IN THESE PLANS IS TO BE CONSTRUED TO PERMIT WORK NOT CONFORMING TO THE LATEST EDITIONS OF THE FOLLOWING CODES.	
<ul style="list-style-type: none"> <li>2015 INTERNATIONAL BUILDING CODE (MASSACHUSETTS AMENDED 9TH EDITION)</li> <li>2017 NATIONAL ELECTRICAL CODE</li> <li>NFPA 1-2015 EDITION</li> <li>2015 IFC - REFERENCE 527 CMR</li> <li>AMERICAN CONCRETE INSTITUTE</li> <li>AMERICAN INSTITUTE OF STEEL CONSTRUCTION</li> <li>MANUAL OF STEEL CONSTRUCTION 13TH EDITION</li> </ul>	<ul style="list-style-type: none"> <li>ANSI/TIA-222-G</li> <li>TIA 607</li> <li>INSTITUTE FOR ELECTRICAL &amp; ELECTRONICS ENGINEER 81</li> <li>IEEE C2 NATIONAL ELECTRIC SAFETY CODE LATEST EDITION</li> <li>TELECORDIA GR-1275</li> <li>ANSI/T 311</li> </ul>

DRAWING INDEX	
01	TITLE SHEET
02	NOTES
03	SITE PLAN
04	ELEVATIONS AND BILL OF MATERIALS
05	ANTENNA DETAILS
06	EQUIPMENT DETAILS
07	GROUNDING DETAILS

**GENERAL NOTES:**

- THE CONTRACTOR SHALL GIVE ALL NOTICE AND COMPLY WITH ALL LAWS, ORDINANCES, RULES, REGULATIONS AND LAWFUL ORDERS OF ANY PUBLIC AUTHORITY, MUNICIPAL AND UTILITY COMPANY SPECIFICATIONS, AND LOCAL AND STATE JURISDICTIONS BEARING ON THE PERFORMANCE OF THE WORK. THE WORK PERFORMED ON THE PROJECT AND THE MATERIALS INSTALLED SHALL BE IN STRICT ACCORDANCE WITH ALL APPLICABLE CODES, REGULATIONS AND ORDINANCES.
- THE ARCHITECT/ENGINEER HAS MADE EVERY EFFORT TO SET FORTH IN THE CONSTRUCTION AND CONTRACT DOCUMENTS THE COMPLETE SCOPE OF WORK. THE CONTRACTOR BIDDING THE JOB IS NEVERTHELESS CAUTIONED THAT MINOR OMISSIONS OR ERRORS IN THE DRAWINGS AND SPECIFICATIONS SHALL NOT EXCUSE SAID CONTRACTOR FROM COMPLETING THE PROJECT AND IMPROVEMENTS IN ACCORDANCE WITH THE INTENT OF THESE DOCUMENTS.
- THE CONTRACTOR OR BIDDER SHALL BEAR THE RESPONSIBILITY OF NOTIFYING (IN WRITING) THE CROWN CASTLE CONSTRUCTION MANAGER OF ANY CONFLICTS, ERRORS, OR OMISSIONS PRIOR TO THE SUBMISSION OF CONTRACTOR'S PROPOSAL OR PERFORMANCE OF WORK. IN THE EVENT OF DISCREPANCIES THE CONTRACTOR SHALL PRICE THE MORE COSTLY OR EXTENSIVE WORK, UNLESS DIRECTED IN WRITING OTHERWISE.
- THE SCOPE OF WORK SHALL INCLUDE FURNISHING ALL MATERIALS, EQUIPMENT, LABOR AND ALL OTHER MATERIALS AND LABOR DEEMED NECESSARY TO COMPLETE THE WORK/PROJECT AS DESCRIBED HEREIN, EXCEPT FOR FIBER OPTIC CABLE AND OTHER MATERIALS IDENTIFIED BY CROWN CASTLE.
- THE CONTRACTOR SHALL VISIT THE JOB SITE PRIOR TO THE SUBMISSION OF BIDS OR PERFORMING WORK TO FAMILIARIZE HIMSELF WITH THE FIELD CONDITIONS AND TO VERIFY THAT THE PROJECT CAN BE CONSTRUCTED IN ACCORDANCE WITH THE CONTRACT DOCUMENTS.
- THE CONTRACTOR SHALL OBTAIN AUTHORIZATION TO PROCEED WITH CONSTRUCTION PRIOR TO STARTING WORK ON ANY ITEM NOT CLEARLY DEFINED BY THE CONSTRUCTION DRAWING/CONTRACT DOCUMENTS.
- THE CONTRACTOR SHALL INSTALL ALL EQUIPMENT AND MATERIALS ACCORDING TO THE MANUFACTURER'S/VENDOR'S SPECIFICATION UNLESS NOTED OTHERWISE OR WHERE LOCAL CODES OR ORDINANCES TAKE PRECEDENCE.
- THE CONTRACTOR SHALL PROVIDE A FULL SET OF CONSTRUCTION DOCUMENTS AT THE SITE UPDATED WITH THE LATEST REVISIONS AND ADDENDUMS OR CLARIFICATIONS AVAILABLE FOR THE USE BY ALL PERSONNEL INVOLVED WITH THE PROJECT.
- THE CONTRACTOR SHALL SUPERVISE AND DIRECT THE PROJECT DESCRIBED HEREIN. THE CONTRACTOR SHALL BE SOLELY RESPONSIBLE FOR ALL CONSTRUCTIONS MEANS, METHODS, TECHNIQUES, SEQUENCES AND PROCEDURES AND FOR COORDINATING ALL PORTIONS OF THE WORK UNDER THE CONTRACT.
- THE CONTRACTOR SHALL BE RESPONSIBLE FOR OBTAINING, AND KEEPING A COPY ON SITE, ALL PERMITS AND INSPECTIONS WHICH MAY BE REQUIRED FOR THE ARCHITECT/ENGINEER, THE STATE, COUNTY OR LOCAL GOVERNMENT AUTHORITY.
- THE CONTRACTOR SHALL MAKE NECESSARY PROVISIONS TO PROTECT EXISTING IMPROVEMENTS, EASEMENTS, PAVING, CURBING, ETC. DURING CONSTRUCTION. UPON COMPLETION OF WORK, THE CONTRACTOR SHALL REPAIR ANY DAMAGE THAT MAY HAVE OCCURRED DUE TO CONSTRUCTION ON OR ABOUT THE PROPERTY TO ORIGINAL OR BETTER CONDITION.
- THE CONTRACTOR SHALL KEEP THE GENERAL WORK AREA CLEAN AND HAZARD FREE DURING CONSTRUCTION AND DISPOSE OF ALL DIRT, DEBRIS, RUBBISH AND REMOVE EQUIPMENT NOT SPECIFIED AS REMAINING ON THE PROPERTY. PREMISES SHALL BE LEFT IN CLEAN CONDITION AND FREE FROM PAINT SPOTS, DUST, OR SMUDGES OF ANY NATURE.
- THE CONTRACTOR SHALL COMPLY WITH ALL OSHA REQUIREMENTS AS THEY APPLY TO THIS PROJECT.
- THE CONTRACTOR SHALL NOTIFY THE CROWN CASTLE CONSTRUCTION MANAGER WHERE A CONFLICT OCCURS ON ANY OF THE CONTRACT DOCUMENTS. THE CONTRACTOR IS NOT TO ORDER MATERIAL OR CONSTRUCT ANY PORTION OF THE WORK THAT IS IN CONFLICT UNTIL IS RESOLVED BY THE CROWN CASTLE CONSTRUCTION MANAGER.
- THE CONTRACTOR SHALL VERIFY ALL DIMENSIONS, ELEVATIONS, PROPERTY LINES, ETC. ON THE PROJECT.
- OWNER/CONTRACTOR SHALL CONTACT ONE CALL NUMBER 72 HOURS PRIOR TO THE START OF CONSTRUCTION FOR LOCATION OF EXISTING UNDERGROUND UTILITIES.
- SUBMITTAL OF BID INDICATES THAT THE CONTRACTOR IS COGNIZANT OF ALL JOB SITE CONDITIONS AND WORK TO BE PERFORMED UNDER THIS CONTRACT.
- THESE PLANS ARE DIAGRAMMATIC ONLY, FOLLOW AS CLOSELY AS POSSIBLE.
- CONTRACTOR SHALL COORDINATE ALL WORK BETWEEN TRADES AND ALL OTHER SCHEDULING AND PROVISIONARY CIRCUMSTANCES SURROUNDING THE PROJECT.
- CONTRACTOR SHALL PROVIDE ALL LABOR, MATERIALS, INSURANCE, EQUIPMENT, INSTALLATION CONSTRUCTION TOOLS, TRANSPORTATION, ETC., FOR COMPLETE AND FUNCTIONALLY OPERATING SYSTEMS ENERGIZED AND READY FOR USE THROUGHOUT AS INDICATED ON DRAWINGS, AS SPECIFIED HEREIN AND/OR AS OTHERWISE REQUIRED.
- CLEAN PREMISES OF ALL DEBRIS RESULTING FROM WORK AND LEAVE WORK IN A COMPLETE AND UNDAMAGED CONDITION. LEGALLY DISPOSE OF ALL REMOVED, UNUSED AND EXCESS MATERIAL GENERATED BY THE WORK OF THIS CONTRACT. DELIVER ITEMS INDICATED ON THE DRAWINGS TO THE OWNER IN GOOD CONDITION. OBTAIN SIGNED RECEIPT UPON DELIVERY.
- AFTER COMPLETION OF CONSTRUCTION, RED LINED AS-BUILT PLANS SHALL BE PROVIDED TO CROWN CASTLE CONSTRUCTION MANAGER.

**ELECTRICAL NOTES:**

- CONTRACTOR SHALL PERFORM ALL VERIFICATIONS, OBSERVATION TESTS, AND EXAMINATION WORK PRIOR TO ORDERING OF ANY EQUIPMENT AND THE ACTUAL CONSTRUCTION. CONTRACTOR SHALL ISSUE A WRITTEN NOTICE OF ALL FINDINGS TO THE PROJECT MANAGER LISTING ALL MALFUNCTIONS, FAULTY EQUIPMENT AND DISCREPANCIES.
- VERIFY HEIGHTS WITH PROJECT MANAGER PRIOR TO INSTALLATION.
- ALL MATERIALS AND EQUIPMENT SHALL BE NEW AND IN PERFECT CONDITION WHEN INSTALLED AND SHALL BE OF THE BEST GRADE AND OF THE SAME MANUFACTURER THROUGHOUT FOR EACH CLASS OR GROUP OF EQUIPMENT. ELECTRICAL MATERIALS SHALL BE LISTED AND APPROVED BY UNDERWRITER'S LABORATORIES AND SHALL BEAR THE INSPECTION LABEL "I" WHERE SUBJECT TO SUCH APPROVAL. MATERIALS SHALL MEET WITH APPROVAL OF ALL GOVERNING BODIES HAVING JURISDICTION OVER THE CONSTRUCTION. MATERIALS SHALL BE MANUFACTURED IN ACCORDANCE WITH ALL CURRENT APPLICABLE STANDARDS ESTABLISHED BY ANSI, NEMA AND NBFU. ALL MATERIALS AND EQUIPMENT SHALL BE APPROVED FOR THEIR INTENDED USE AND LOCATION.
- ALL WORK SHALL COMPLY WITH ALL APPLICABLE GOVERNING STATE, COUNTY AND CITY CODES AND OSHA, NFPA, NEC & ASHRAE REQUIREMENTS.
- ENTIRE JOB SHALL BE GUARANTEED FOR A PERIOD OF ONE (1) YEAR AFTER THE DATE OF JOB ACCEPTANCE. ALL WORK, MATERIAL AND EQUIPMENT FOUND TO BE FAULTY DURING THAT PERIOD SHALL BE CORRECTED AT ONCE, UPON WRITTEN NOTIFICATION, AT THE EXPENSE OF THE CONTRACTOR.
- PROPERLY SEAL ALL PENETRATIONS. PROVIDE UL LISTED FIRE-STOPS WHERE PENETRATIONS ARE MADE THROUGH FIRE-RATED ASSEMBLIES. WATER-TIGHT USING SILICONE SEALANT.
- DELIVER ALL BROCHURES, OPERATING MANUALS, CATALOGS AND SHOP DRAWINGS TO THE PROJECT MANAGER AT JOB COMPLETION. PROVIDE MAINTENANCE MANUALS FOR MECHANICAL EQUIPMENT. AFFIX MAINTENANCE LABELS TO MECHANICAL EQUIPMENT.
- ALL CONDUCTORS SHALL BE COPPER. MINIMUM CONDUCTOR SIZE SHALL BE #12 AWG., UNLESS OTHERWISE NOTED. CONDUCTORS SHALL BE TYPE THW, RATED IN ACCORDANCE WITH NEC 110-14(C).
- ALL CIRCUIT BREAKERS, FUSES AND ELECTRICAL EQUIPMENT SHALL HAVE AN INTERRUPTING RATING NOT LESS THAN THE MAXIMUM INTERRUPTING CURRENT TO WHICH THEY MAY BE SUBJECTED.
- THE ENTIRE ELECTRICAL INSTALLATION SHALL BE GROUNDED IN ACCORDANCE WITH THE NATIONAL ELECTRICAL CODE; ARTICLES 250 & 810 AND THE UTILITY COMPANY STANDARDS.
- CONDUIT:**
  - RIGID CONDUIT SHALL BE U.L. LABEL GALVANIZED ZINC COATED WITH ZINC INTERIOR AND SHALL BE USED WHEN INSTALLED IN OR UNDER CONCRETE SLABS, IN CONTACT WITH THE EARTH, UNDER PUBLIC ROADWAYS, IN MASONRY WALLS OR EXPOSED ON BUILDING EXTERIOR. RIGID CONDUIT IN CONTACT WITH EARTH SHALL BE 1/2 LAPPED WRAPPED WITH HUNTS WRAP PROCESS NO. 3.
  - ELECTRICAL METALLIC TUBING SHALL HAVE U.L. LABEL, FITTINGS SHALL BE GLAND RING COMPRESSION TYPE. EMT SHALL BE USED ONLY FOR INTERIOR RUNS.
  - LIQUID-TIGHT FLEXIBLE METAL CONDUIT SHALL BE U.L. LISTED AND SHALL BE USED AT FINAL CONNECTIONS TO MECHANICAL EQUIPMENT & RECTIFIERS AND WHERE PERMITTED BY CODE. ALL CONDUIT IN EXCESS OF SIX FEET IN LENGTH SHALL CONTAIN A FULL-SIZE GROUND CONDUCTOR.

- CONDUIT RUNS SHALL BE SURFACE MOUNTED ON CEILINGS OR WALLS UNLESS NOTED OTHERWISE. ALL CONDUIT SHALL RUN PARALLEL OR PERPENDICULAR TO WALLS, FLOOR, CEILING, OR BEAMS. VERIFY EXACT ROUTING OF ALL EXPOSED CONDUIT WITH THE PROJECT MANAGER PRIOR TO INSTALLING.
- PVC CONDUIT MAY BE PROVIDED ONLY WHERE SHOWN, OR IN UNDERGROUND INSTALLATIONS. PROVIDE UV-RESISTANT CONDUIT WHERE EXPOSED TO THE ATMOSPHERE. PROVIDE GROUND CONDUCTOR IN ALL PVC RUNS; EXCEPT WHERE PERMITTED BY CODE TO OMIT.
- ALL ELECTRICAL EQUIPMENT SHALL BE LABELED WITH PERMANENT ENGRAVED PLASTIC LABELS. BACKGROUND SHALL BE BLACK WITH WHITE LETTERS; EXCEPT AS REQUIRED BY CODE TO FOLLOW A DIFFERENT SCHEME.
- UPON COMPLETION OF WORK, CONDUCT CONTINUITY, SHORT CIRCUIT, AND FALL OF POTENTIAL GROUNDING TESTS FOR APPROVAL. SUBMIT TEST REPORTS TO PROJECT MANAGER. GROUNDING SYSTEM RESISTANCE SHALL NOT EXCEED 5 OHMS. IF THE RESISTANCE VALUE IS EXCEEDED, NOTIFY THE PROJECT MANAGER FOR FURTHER INSTRUCTION ON METHODS FOR REDUCING THE RESISTANCE VALUE.
- COORDINATE WITH UTILITY COMPANY FOR CONNECTION OF TEMPORARY AND PERMANENT POWER TO THE SITE. THE TEMPORARY POWER AND ALL HOOKUP COSTS SHALL BE PAID BY THE CONTRACTOR.
- VERIFY ALL EXISTING CIRCUITRY PRIOR TO REMOVAL AND NEW WORK. MAINTAIN POWER TO ALL OTHER AREAS & CIRCUITS NOT SCHEDULED FOR REMOVAL.

**GROUNDING NOTES:**

- GROUNDING SHALL COMPLY WITH ARTICLE 250 OF THE NATIONAL ELECTRICAL CODE.
- ALL GROUNDING DEVICES SHALL BE U.L. APPROVED OR LISTED FOR THEIR INTENDED USE.
- ALL WIRES SHALL BE AWG THHN/THWN COPPER UNLESS NOTED OTHERWISE.
- GROUNDING CONNECTIONS TO GROUND RODS, GROUND RING WIRE, TOWER BASE AND FENCE POSTS SHALL BE EXOTHERMIC ("CADWELDS") UNLESS NOTED OTHERWISE. CLEAN SURFACES TO SHINY METAL. WHERE GROUND WIRES ARE CADWELDED TO GALVANIZED SURFACES, SPRAY CADWELD WITH GALVANIZING PAINT.
- GROUNDING CONNECTIONS TO GROUND BARS ARE TO BE TWO-HOLE BRASS MECHANICAL CONNECTORS WITH STAINLESS STEEL HARDWARE (INCLUDING SCREW SET) CLEAN GROUND BAR TO SHINY METAL. AFTER MECHANICAL CONNECTION, TREAT WITH PROTECTIVE ANTIOXIDANT COATING.
- GROUND COAXIAL CABLE SHIELDS AT BOTH ENDS WITH MANUFACTURER'S GROUNDING KITS.
- ROUTE GROUNDING CONDUCTORS THE SHORTEST AND STRAIGHTEST PATH POSSIBLE. BEND GROUNDING LEADS WITH A MINIMUM 12" RADIUS.
- INSTALL #6 AWG GREEN-INSULATED STRANDED WIRE FOR ABOVE GRADE GROUNDING AND #4 TINNED SOLID COPPER WIRE FOR BELOW GRADE GROUNDING UNLESS OTHERWISE NOTED.
- REFER TO GROUNDING PLAN FOR GROUND BAR LOCATIONS. GROUNDING CONNECTIONS SHALL BE EXOTHERMIC TYPE ("CADWELDS") TO ANTENNA MOUNTS AND GROUND RING. REMAINING GROUNDING CONNECTIONS SHALL BE COMPRESSION FITTINGS. CONNECTIONS TO GROUND BARS SHALL BE MADE WITH TWO-HOLE LUGS.
- THE GROUND ELECTRODE SYSTEM SHALL CONSIST OF DRIVEN GROUND RODS POSITION ACCORDING TO GROUNDING PLAN. THE GROUND RODS SHALL BE 5/8"x8"-0" COPPER CLAD STEEL INTERCONNECTED WITH #4 TINNED SOLID COPPER WIRE BURIED 36" BELOW GRADE. BURY GROUND RODS A MAXIMUM OF 15' APART, AND A MINIMUM OF 6' APART (SECOND GROUND ROD ONLY REQUIRED IF RESISTIVITY TEST FAILS).
- IF ROCK IS ENCOUNTERED GROUND RODS SHALL BE PLACED AT AN OBLIQUE ANGLE NOT TO EXCEED 45°.
- EXOTHERMIC WELDS SHALL BE MADE IN ACCORDANCE WITH ERICO PRODUCTS BULLETIN A-AT OR EQUAL.
- CONSTRUCTION OF GROUND RING AND CONNECTIONS TO EXISTING GROUND RING SYSTEM SHALL BE DOCUMENTED WITH PHOTOGRAPHS PRIOR TO BACKFILLING SITE. PROVIDE PHOTOS TO THE CROWN CASTLE CONSTRUCTION MANAGER.
- ALL GROUND LEADS EXCEPT THOSE TO THE EQUIPMENT ARE TO BE #2 TINNED SOLID COPPER WIRE. ALL EXTERIOR GROUND BARS TINNED COPPER.
- PRIOR TO INSTALLING LUGS ON GROUND WIRES, APPLY THOMAS & BETTS KOPR-SHIELD (TM OF JET LUBE INC.). PRIOR TO BOLTING GROUND WIRE LUGS TO GROUND BARS, APPLY KOPR-SHIELD OR EQUAL.
- ENGAGE AN INDEPENDENT ELECTRICAL TESTING FIRM TO TEST AND VERIFY THAT IMPEDANCE DOES NOT EXCEED FIVE OHMS TO GROUND BY MEANS OF "FALL OF POTENTIAL TEST".
- WHERE BARE COPPER GROUND WIRES ARE ROUTED FROM ANY CONNECTION ABOVE GRADE TO GROUND RING, INSTALL WIRE IN 3/4" PVC SLEEVE, FROM 1' BELOW GRADE AND SEAL TOP WITH SILICONE MATERIAL.
- PREPARE ALL BONDING SURFACES FOR GROUNDING CONNECTIONS BY REMOVING ALL PAINT AND CORROSION DOWN TO SHINY METAL. FOLLOWING CONNECTION, APPLY APPROPRIATE ANTI-OXIDIZATION PAINT.
- ANY SITE WHERE THE EQUIPMENT (BTS, CABLE BRIDGE, PPC, GENERATOR, ETC.) IS LOCATED WITHIN 6 FEET OF METAL FENCING, THE GROUND RING SHALL BE BONDED TO THE NEAREST FENCE POST USING (3) RUNS OF #2 BARE TINNED COPPER WIRE.

**GROUNDING GUIDELINES:**

ALL EQUIPMENT THAT IS INSTALLED AND MAY CAUSE ANY KIND OF ELECTRICAL CHARGE OR BUILD UP MUST HAVE PROPER AND ADEQUATE GROUNDING IN PLACE TO PREVENT FROM EQUIPMENT DAMAGE AND SHOCK HAZARDS.

**RHH'S**  
MUST BE GROUND TO A MAIN BUSS BAR OR HOME RUN GROUND FROM THE GROUND PIN OR STUD THAT IS ON THE CHASSIS. IF ANY EQUIPMENT HAS A GROUND POINT ON IT, IT SHOULD BE GROUND TO THE GROUNDING CABLE SIZE SHOULD FOLLOW LOCAL GUIDELINES ON EQUIPMENT GROUNDING. NORMALLY THE STANDARD IS 6 UV RATED STRANDED GROUND CABLE TO BE USED ON RHH'S. THE LUG NEEDS TO FIT THE PROPER CABLE SIZE AS WELL AS THE HOLE SIZE FOR THE STUD. IF IT'S A SINGLE STUD IT SHOULD BE A ONE HOLE LUG, IF IT HAS A PLACE FOR TWO HOLE LUG THEN THAT SHOULD BE USED. (I.E. COMMSCOPE ION M HAS A SINGLE STUD GROUND, TE PRISM HAS A GROUND FOR A 2 HOLE LUG.) DO NOT CUT THE LUGS TO FIT. THEY MAKE LUGS IN ALL SHAPES AND SIZES. ORDER THE CORRECT ONE AND ATTACH IT PROPERLY.

**COAX GROUNDS**  
IN LINE GROUNDS SHOULD BE INSTALLED WITH THE PROPER SIZE GROUND KITS ON ALL COAX CABLES. THE KITS ARE INSTALLED ON FRONT AND BACK OF COAX RUNS OVER APPROXIMATELY 15 FEET. ANYTHING OVER 300 FEET NEEDS AN ADDITIONAL GROUND AROUND THE 150 FOOT MARK.

**SURGE ARRESTORS**  
IF IT HAS A PLACE FOR A GROUND - GROUND IT.

**MAST PIPES**  
ALL MAST PIPES SHOULD BE GROUND WITH BEAR METAL ON THE PLACE THE GROUND IS ATTACHED AND THEN COLD GALVANIZATION OVER THE BARE METAL TO PREVENT RUST. THE GROUND CAN BE ATTACHED MECHANICALLY TO AN EXOTHERMIC WELD (CAD WELD) MAY BE USED. IF THE MAST PIPE IS THE TALLEST POINT ON A BUILDING IT SHOULD ALSO HAVE A LIGHTNING ROD ATTACHED TO IT AS WELL.

**DIPLEXERS/DUPLEXERS/SPLITTERS/PASSIVE COMPONENTS**  
IF IT HAS A PLACE FOR A GROUND TO BE INSTALLED - INSTALL IT.

ANY STRUCTURE OR FRAME SHOULD HAVE 2 GROUND WIRE, I.E. MAST PIPES, OUTDOOR ENCLOSURES, SHROUDS, BUSS BAR HOME RUN TO EARTH GROUND. ALL EQUIPMENT HAS 6 TO BUSS BARS.

ALL BUSS BARS NEED TO HAVE A LINK TO AN EARTH GROUND SYSTEM AND MUST BE ISOLATED IF MOUNTED ON ANYTHING THAT MAY RETAIN AN ELECTRIC CHARGE. NO EXCEPTIONS. ALL EQUIPMENT SHOULD RUN TO BUSS BARS. LUGS ON BUSS BARS SHOULD HAVE FRONT AND BACK FLAT WASHERS SANDWICHING THE LUG(S) TO THE BAR AND NOT OVERLAPPING CAUSING IT TO HOLD OR PIN DOWN OTHER LUGS ON THE BAR. THERE SHOULD ALWAYS BE A LOCK WASHER CLOSEST TO THE NUT ON THE BOLT FOR A LUG. NEVER IS IT OK TO STACK LUGS ON TOP OF EACH OTHER. IF THERE IS NOT ENOUGH SPACE, GET A BIGGER BUSS BAR. THEY SHOULD ALL HAVE A DIRECT CONTACT TO A BUSS BAR WITH NO-OX COATED BETWEEN THE LUG AND THE BUSS BAR. ALL GROUNDS SHOULD HAVE HEAT SHRINK OVER THE LUG (UNLESS IT'S NON-JACKETED WIRE). ALL LUGS NEED TO BE CRIMPED ON SECURELY WITH THE PROPER DYE AND TOOL (NOT CHANNEL LOCK CRIMPED). THERE SHOULD BE NO MORE THAN 1/16 INCH BARE CABLE SHOWING (SHINER) BETWEEN THE JACKET AND THE LUG. INSIDE LUGS SHOULD HAVE CLEAR HEAT SHRINK TO INSPECT THE CRIMPS AND SHINERS. INSIDE LUGS SHOULD HAVE INSPECTION WINDOWS TO SHOW THE GROUND WIRE IS INSERTED INTO THE LUG ALL THE WAY AND IS PROPERLY INSTALLED. OUTDOOR LUGS MAY HAVE BLACK OR GREEN HEAT SHRINK.

**WEATHER SEAL GUIDELINES:**

**BUTYL**

- PRE WRAP ALL CONNECTIONS WITH BLACK ELECTRICAL TAPE TO COVER ALL METAL SHOWING TO PREVENT DAMAGE TO CONNECTOR WHEN WEATHER SEAL IS TO BE REMOVED. 3/4 INCH OR 2 INCH TAPE CAN BE USED FOR THIS PROCESS.
- WRAP CONNECTIONS WITH BUTYL WEATHER SEALANT WITH TWO LAYERS TO FORM A CONE LIKE SHAPE. OVER LAPPING THE LAYERS BY AT LEAST 50%. MOLD SEALANT TO PROPER SHAPE. THIS STEP IS CRUCIAL OR THE BUTYL WILL LEAK OVER TIME.
- WRAP SEALANT WITH 2 LAYERS OF 2 INCH TAP. (YOU CAN CUT INTO STRIPS IN TIGHT AREAS). FIRST WRAP SHOULD BE PULLED SMOOTH TO MAKE FINAL WRAPS CLEAN AND CRISP. 2ND WRAP SHOULD BE PULLED TIGHTER THAN FIRST TO HOLD SEALANT INTO PROPER (CONE LIKE) SHAPE. OVER LAPPING TAPE SHOULD COVER AT LEAST 50% OF EACH LAYER OF TAPE PRIOR.
- UPON COMPLETION OF 2 LAYERS OF 2 INCH TAPE FINALIZE WITH AT LEAST 3 LAYERS OF 3/4 INCH TAPE. EACH WRAP OF TAPE SHOULD BE PULLED TIGHTER THAN WRAP BEFORE TO SQUEEZE SEALANT INTO A MOLD AND WILL PREVENT ANY SEALANT FROM LEAKING OUT THE SIDES OVER TIME. EACH LAYER SHOULD COVER PRIOR LAYERS AT LEAST 50%.
- OVERLAP THE TAPE 50% OF THE PREVIOUS LAYER.
- ALWAYS FINISH THE LAST WRAP OF TAPE GOING UP TO CREATE A SHINGLING OF THE TAPE SO IN THE WEATHER ANYTHING THAT RUNS DOWN THE CABLE WILL NOT LEAK INTO THE SEALANT. CUT THE END OF THE TAPE AND LAY IT ONTO THE FINISH. DO NOT STRETCH THE END OF THE TAPE. THIS WILL CAUSE THE TAPE TO PULL OFF OVER TIME AND CREATE A FLAGGING AFFECT.

**FUSION TAPE**

- CHECK TO MAKE SURE ALL CONNECTORS ARE TORQUED TO PROPER SPECIFICATIONS BEFORE YOU BEGIN.
- NOTE: THIS STEP DOES NOT NEED A CURTUSY WRAP BECAUSE THE TAPE DOES NOT ACTUALLY ADHERE TO THE CONNECTOR ITSELF BUT BINDS TO ITSELF. ALSO KNOWN AS "SELF-AMALGAMATING TAPE."
- WRAP CONNECTIONS FUSION TAPE SEALANT WITH TWO LAYERS TO FORM A CONE LIKE SHAPE. FUSION TAPE MUST OVER LAP AT LEAST 50% TO FORM A PROPER SEAL. COVER ALL OF THE BARE METAL SHOWING (AT LEAST 1-1/2 INCH PAST END OF CONNECTOR.)
- IF THIS "TAPE" IS NOT PULLED TIGHT WHILE WRAPPING YOU WILL NOT CREATE A PROPER SEAL, IT MUST BE STRETCHED TO CREATE BOND TO ITSELF.
- WRAP AT LEAST 2 LAYERS OF 3/4 INCH TAPE. EACH LAYER SHOULD COVER AT LEAST 50% OF PREVIOUS TAPE WRAP.
- ALWAYS FINISH THE LAST WRAP OF TAPE GOING UP TO CREATE A SHINGLING OF THE TAPE SO IN THE WEATHER ANYTHING THAT RUNS DOWN THE CABLE WILL NOT LEAK INTO THE SEALANT. CUT THE END OF THE TAPE AND LAY IT ONTO THE FINISH. DO NOT STRETCH THE END OF THE TAPE. THIS WILL CAUSE THE TAPE TO PULL OFF OVER TIME AND CREATE A FLAGGING AFFECT.

**HEAT SHRINK**

- PRE WRAP ALL CONNECTIONS WITH BLACK ELECTRICAL TAPE TO COVER ALL METAL SHOWING TO PREVENT DAMAGE TO CONNECTOR WHEN WEATHER SEAL IS TO BE REMOVED. 3/4 INCH OR 2 INCH TAPE CAN BE USED FOR THIS PROCESS.
- USE ONLY OUTDOOR RATED HEAT SHRINK THAT HAS THE SELF-ADHESIVE WHEN HEATED PROPERLY. THIS IS WHAT WILL CREATE THE SEAL TO THE CONNECTOR.
- MAKE SURE HEAT SHRINK COVERS ALL OF THE COUPLERS AND CONNECTIONS. HEAT THE HEAT SHRINK TO SHRINK TIGHTLY TO THE CONNECTIONS AND CABLE. MAKE SURE THE HEAT SHRINK IS SEALED TOP AND BOTTOM OF THE CONNECTIONS. ALSO CHECK TO MAKE SURE HEAT SHRINK WAS NOT OVER HEATED AND THERE ARE NO BREAKS IN SEAL THROUGH-OUT THE SHRINK TUBING.

**ANDREWS CLAM SHALL**

- PROPERLY TORQUE CONNECTOR TO SPECIFICATION.
- APPLY ONE LAYER OF 3/4 INCH BLACK TAPE AROUND ENTIRE CONNECTOR ENDING AT LEAST 1-1/2 INCHES PAST TOP AND BOTTOM OF CONNECTOR TO PREVENT ANY MOISTURE FROM STICKING TO THE CONNECTOR.
- INSPECT THE DEVICE TO MAKE SURE IT IS NOT CHIPPED, CRACKED OR ANY SIGNS OF NEGLECT THAT WILL TAKE AWAY FROM MAKING A FULL SEAL AROUND THE CONNECTOR.
- USE ONLY CORRECT SIZE PER CABLE AND CONNECTOR TYPE - I.E. 1/2 INCH FOR 1/2 INCH NOT 7/8TH FOR 1/2 INCH.
- FOLLOW DIRECTIONS THAT COME WITH PRODUCT - MOST CLAM SHELL TYPE SEALANT DEVICES WRAP AROUND OR CLAMP AROUND A CONNECTION POINT.
- BE CAREFUL WHEN SETTING LOCKING DEVICE INTO PLACE ON CLAM SHELL STYLE SEALANTS (THEY ARE PLASTIC AND TEND TO BREAK OR CRACK IN EXTREME WEATHER CONDITIONS WHEN LOCKING DEVICE CLOSED TO CREATE THE SEAL.) IF THE LOCKING MECHANISM CRACKS OR BREAKS, REPLACE IT. DO NOT TAPE THE CLAMP CLOSED OR TRY TO RE-ENGINEER IT.
- ONCE THE CLAMP IS ON AND LOCKED AROUND THE CONNECTOR THE PROCESS IS COMPLETE.

**PPC BOOT**

- PLACE BOOT OVER CABLE BEFORE CONNECTOR IS ATTACHED TO CABLE. THIS IS ONLY RATED FOR PPC TYPE CONNECTORS. (NOTE: IF THIS STEP IS SKIPPED OR NOT COMPLETED BEFORE MAKING A CONNECTOR THE SUBCONTRACTOR WILL NOT BE ABLE TO USE THE BOOT STYLE DEVICE TO SEAL THE CONNECTOR. IT IS NOT RECOMMENDED TO WASTE A CONNECTOR AND CUT IT OFF AND START AT STEP NO. 1 AGAIN. SINCE PPC CONNECTORS ARE NOT REUSABLE AND CAN GET QUITE EXPENSIVE. DO NOT TRY TO STRETCH THE BOOT TO SLIDE IT OVER THE CONNECTION.)
- PLACE THE BOOT OVER THE CABLE, AND THEN MAKE THE CONNECTOR.
- TORQUE THE CONNECTION TO PROPER SPECIFICATIONS.
- SLIDE BOOT UP TO COVER THE ENTIRE CONNECTOR, FOLLOWING THE PPC GUIDELINES.
- THIS PROCESS IS COMPLETE AT THIS TIME.

**ENGINEERING FIRM**

**APPLICANT**

**SITE INFORMATION**

BS90XSG91  
ODAS\_2D-24 / 406411  
1 BENEDICT STREET  
SOMERVILLE, MA 02145  
MIDDLESEX COUNTY

**DESIGN RECORD**

REVISIONS			
REV	DATE	DESCRIPTION	BY
1	09/06/19	FINAL	DRG
0	07/27/18	PRELIMINARY	DRG

**PROFESSIONAL STAMP**

**ENGINEER**

KRUPAKARAN KOLANDAIVELU, P.E.  
MA PROFESSIONAL ENGINEER LIC. #50019

**SHEET TITLE**

**NOTES**

**SHEET NUMBER**

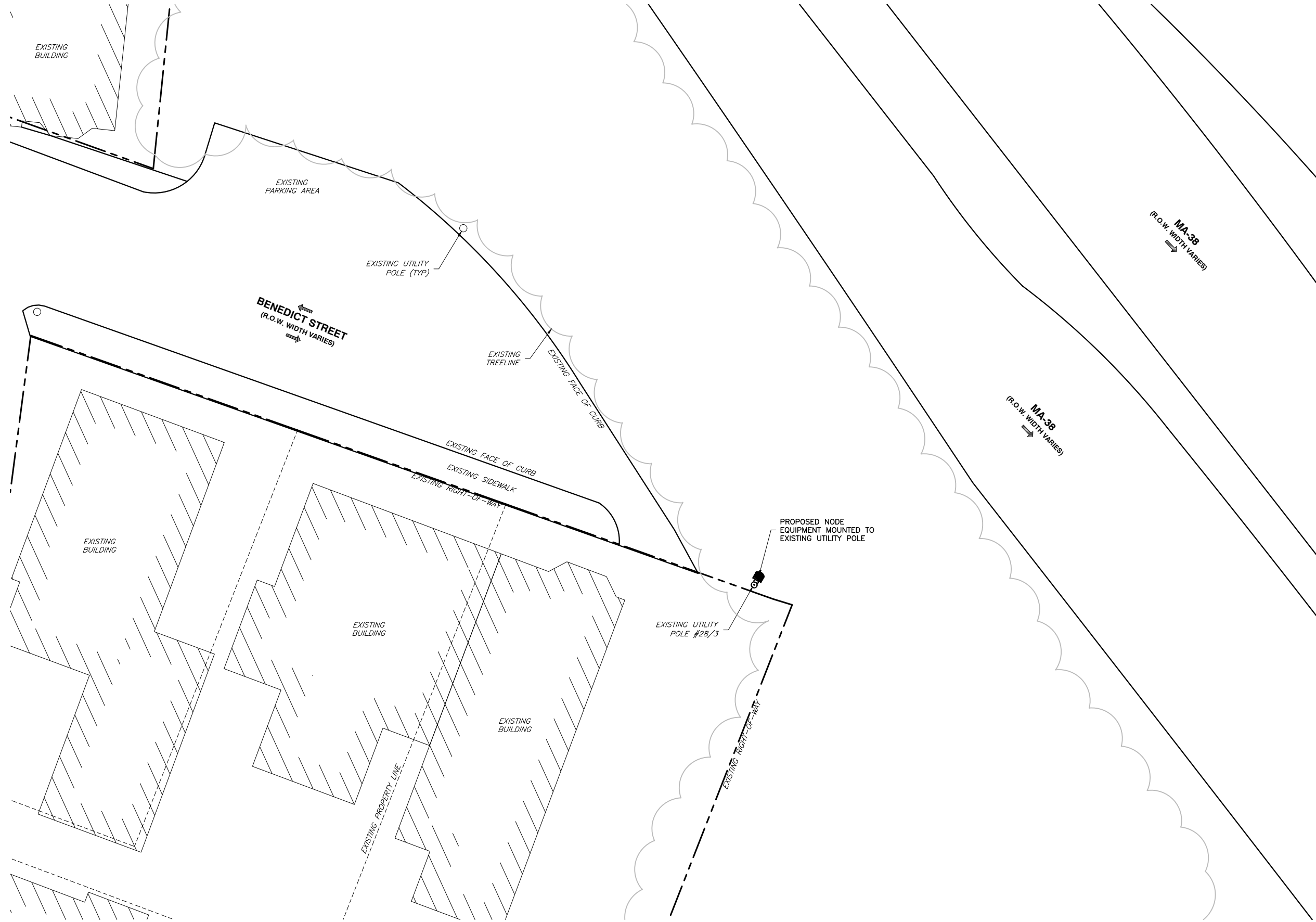

SHEET  
**02 OF 07**

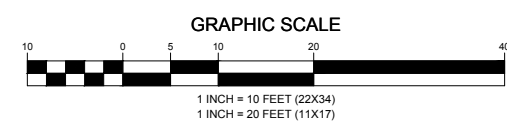

**SITE PLAN**

**NOTE:**  
 EXISTING UTILITY INFORMATION SHOWN REPRESENTS THE BEST DATA AVAILABLE FROM EXISTING DOCUMENTATION AND FIELD EVIDENCE. ALL LOCATIONS SHOULD BE CONSIDERED APPROXIMATE, AND A FIELD INVESTIGATION MUST BE PERFORMED IN THE VICINITY OF ANY CONSTRUCTION ACTIVITIES. NOTE THAT THESE PLANS MAY NOT SHOW ALL UTILITIES THAT ARE PRESENT AT THE SITE.



ENGINEERING FIRM	 <b>TOTALLY COMMITTED.</b> <b>NB+C ENGINEERING SERVICES, LLC.</b> <small>100 APOLLO DRIVE, SUITE 303        CHELMSFORD, MA 01824        (978) 856-8308</small>																
APPLICANT	 <b>CROWN CASTLE</b> <small>CROWN CASTLE NG CENTRAL, LLC        2000 CORPORATE DRIVE        CANONSBURG, PA 15317        (713) 570-3000</small>																
SITE INFORMATION	<small>BS90XSG91        ODAS_2D-24 / 406411        1 BENEDICT STREET        SOMERVILLE, MA 02145        MIDDLESEX COUNTY</small>																
DESIGN RECORD	<table border="1"> <thead> <tr> <th colspan="4">REVISIONS</th> </tr> <tr> <th>REV</th> <th>DATE</th> <th>DESCRIPTION</th> <th>BY</th> </tr> </thead> <tbody> <tr> <td>1</td> <td>09/06/19</td> <td>FINAL</td> <td>DRG</td> </tr> <tr> <td>0</td> <td>07/27/18</td> <td>PRELIMINARY</td> <td>DRG</td> </tr> </tbody> </table>	REVISIONS				REV	DATE	DESCRIPTION	BY	1	09/06/19	FINAL	DRG	0	07/27/18	PRELIMINARY	DRG
REVISIONS																	
REV	DATE	DESCRIPTION	BY														
1	09/06/19	FINAL	DRG														
0	07/27/18	PRELIMINARY	DRG														
PROFESSIONAL STAMP																	
ENGINEER	<small>KRUPAKARAN KOLANDAIVELU, P.E.        MA PROFESSIONAL ENGINEER LIC. #50019</small>																
SHEET TITLE	<p align="center"><b>SITE PLAN</b></p>																
SHEET NUMBER	<p align="center"><b>SHEET 03 OF 07</b></p>																

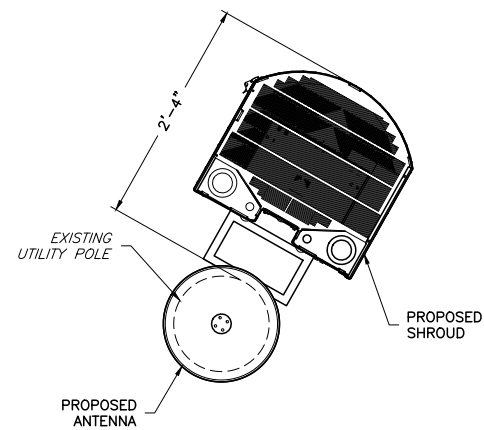

**TOP VIEW**  
NOT TO SCALE

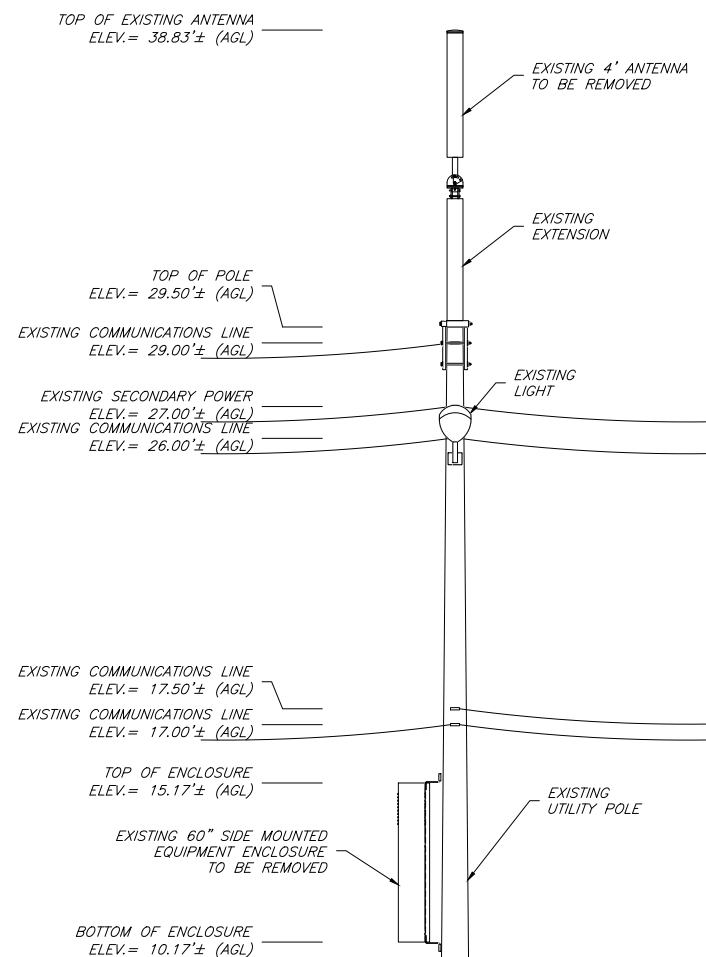

GROUND ELEV. = 0.00'

**EXISTING ELEVATION (LOOKING SOUTHEAST)**

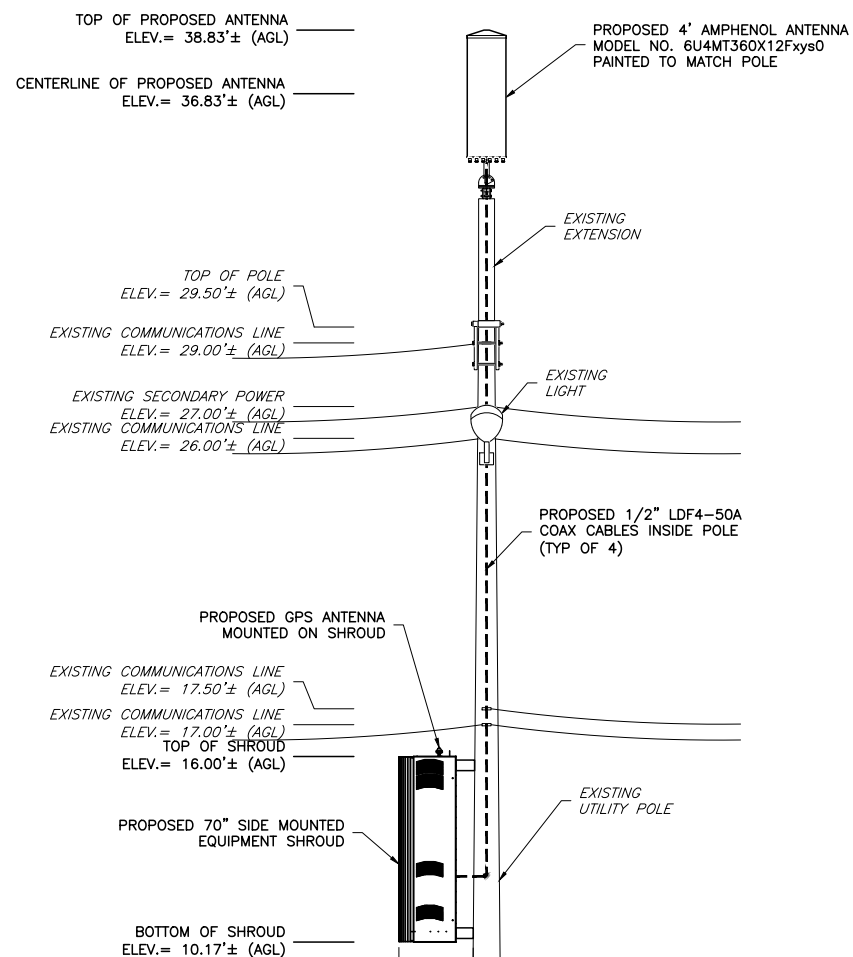
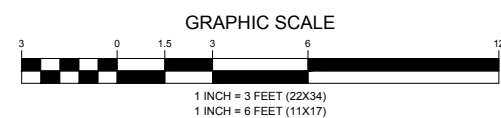

GROUND ELEV. = 0.00'

**PROPOSED ELEVATION (LOOKING SOUTHEAST)**

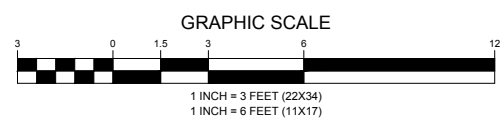

**EXISTING CONDITIONS**



**PROPOSED CONDITIONS**

**BILL OF MATERIALS:**

1. (1) PROPOSED AMPHENOL ANTENNA 48.0" X 14.6"ø MODEL NO. 6U4MT360X12FxyS0
2. (1) PROPOSED NOKIA GPS ANTENNA
3. (4) PROPOSED 1/2" LDF4-50A COAX CABLES
4. (1) PROPOSED NOKIA TD-LTE, BAND 41, 2x20W MINI-MACRO RADIO (FWHR)
5. (2) PROPOSED COMMSCOPE ION-ML 7P/85P/17P/19P (PN: 7629728-0006)
6. (1) PROPOSED CHARLES INDUSTRIES SHROUD PART# SHRD60-601x7GN1
7. (1) PROPOSED AC LOAD CENTER LOCATED INSIDE SHROUD

ENGINEERING FIRM

**NB+C**  
TOTALLY COMMITTED.  
NB+C ENGINEERING SERVICES, LLC.  
100 APOLLO DRIVE, SUITE 303  
CHELMSFORD, MA 01824  
(978) 856-8308

APPLICANT

**CROWN CASTLE**  
CROWN CASTLE NG CENTRAL, LLC  
2000 CORPORATE DRIVE  
CANONSBURG, PA 15317  
(713) 570-3000

SITE INFORMATION

BS90XSG91  
ODAS\_2D-24 / 406411  
1 BENEDICT STREET  
SOMERVILLE, MA 02145  
MIDDLESEX COUNTY

DESIGN RECORD

**REVISIONS**

REV	DATE	DESCRIPTION	BY
1	09/06/19	FINAL	DRG
0	07/27/18	PRELIMINARY	DRG

PROFESSIONAL STAMP



ENGINEER

KRUPAKARAN KOLANDAIVELU, P.E.  
MA PROFESSIONAL ENGINEER LIC. #50019

SHEET TITLE

**ELEVATIONS  
AND BILL OF  
MATERIALS**

SHEET NUMBER

SHEET  
**04 OF 07**



ENGINEERING FIRM

APPLICANT

SITE INFORMATION

DESIGN RECORD

PROFESSIONAL STAMP

ENGINEER

SHEET TITLE

SHEET NUMBER

REVISIONS

REV	DATE	DESCRIPTION	BY
1	09/06/19	FINAL	DRG
0	07/27/18	PRELIMINARY	DRG



KRUPAKARAN KOLANDAIVELU, P.E.  
MA PROFESSIONAL ENGINEER LIC. #50019

ANTENNA DETAILS

SHEET  
**05 OF 07**

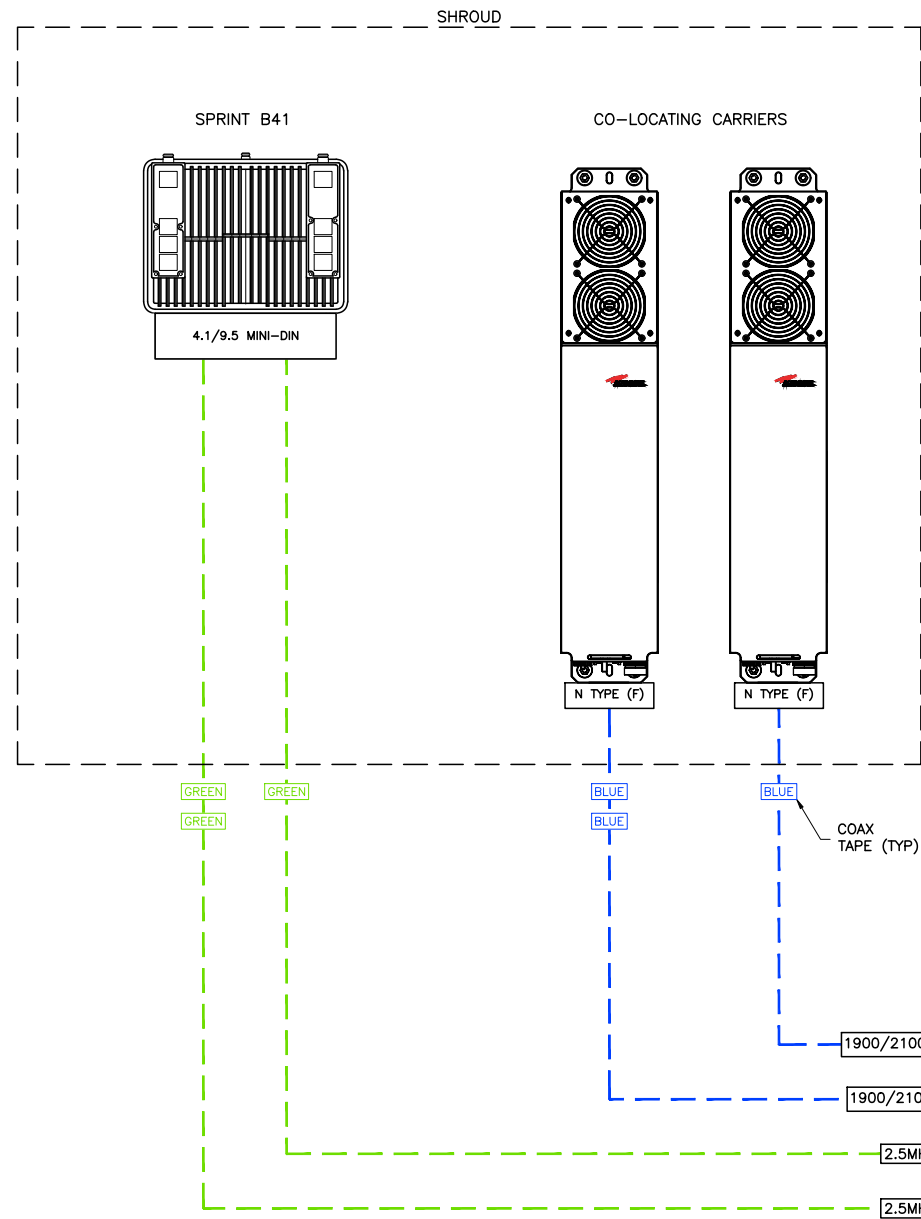

1  
05  
NTS  
ANTENNA PLUMBING DIAGRAM

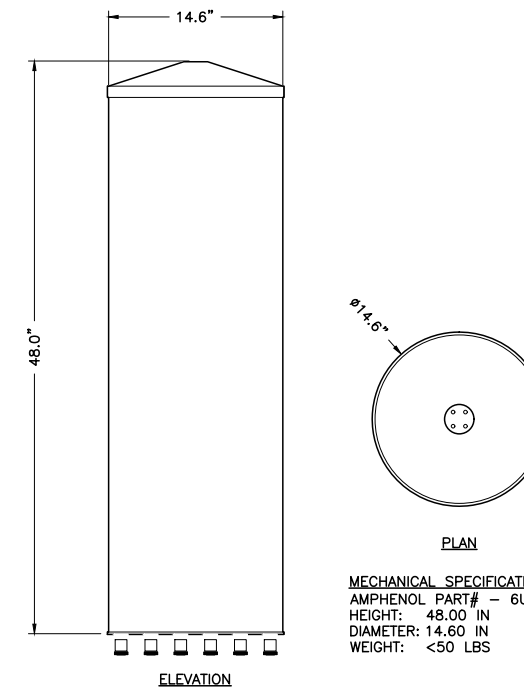
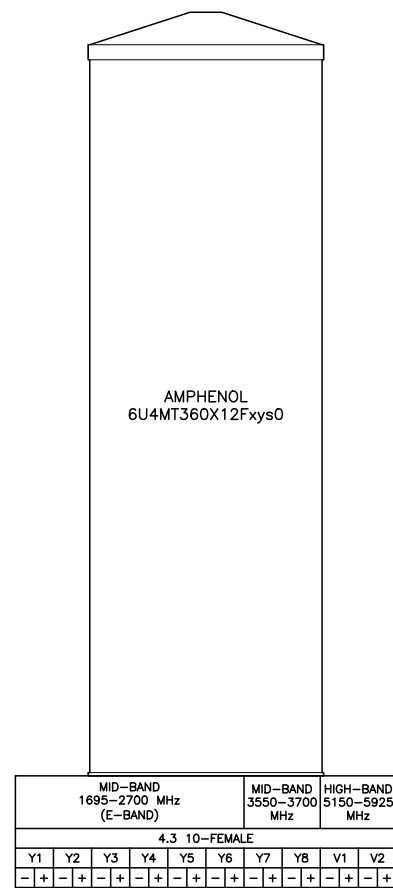

2  
05  
NTS  
ANTENNA DETAIL

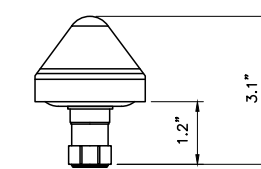

3  
05  
NTS  
GPS ANTENNA DETAIL

RF CABLE-FIELD FAB  
HELIAX 1/2" LDF4-50A  
COAXIAL CABLE (TYP)

COAX TAPE (TYP)

**GENERAL NOTES:**

- METAL TO METAL CONTACT IS NOT ALLOWED WITHOUT AN INTENTIONAL BOND.
- DISSIMILAR METALS IN DIRECT CONTACT, CAUSE CHEMICAL REACTION BETWEEN THE METALS, LEADING TO CORROSION.
- ALL ABOVE GROUND CONNECTIONS TO THE VERTICAL GROUND RISER (VGR) SHALL BE IRREVERSIBLE CLAMP TYPE AND WEATHER PROOFED.
- WHERE APPLICABLE EARTH GROUND RESISTANCE OF 5 OHMS OR LESS IS PREFERRED. 25 OHMS IS ACCEPTABLE SEE NEC 250.53.
- ALL METALLIC SURFACES AND/OR GROUND COMPONENTS INSTALLED W/IN 6" OF EACH OTHER MUST BE PROPERLY BONDED TO VGR, INCLUDING BUT NOT LIMITED TO, RADIO SHROUD, ANTENNA BRACKETS, STREET LIGHTS AND THE METER/LOAD CENTER OF THE AC SERVICE.
- RF GROUND KITS ARE NOT REQUIRED WHERE RF SURGE PROTECTION DEVICES (SPDS) ARE INSTALLED AHEAD OF THE RF CABLES ENTRY POINT INTO THE SHROUD. GROUND AVAILABLE SPDS TO VGR.
- WHEN A NEW FOUNDATION IS INSTALLED, BOND THE AVAILABLE REBAR TO THE SITE GROUNDING.
- WHEN GROUNDING EQUIPMENT INSIDE A SHROUD, CONNECT TO THE SHROUD MANUFACTURER'S GROUND BUSS BAR, AND WATERFALL THE GROUND WIRE FROM THE SHROUD IN A DOWNWARD SWEEPING MOTION TO THE VGR. AVOID GROUND LOOPS THROUGH THE EQUIPMENT CHASSIS TO THE METALLIC SHROUD.
- FOR METAL POLES BOND THE POLE TO THE VGR. FOR ELECTRIC METERS INSTALLED ON METAL POLES, AVOID UNINTENTIONAL BONDING THROUGH THE CHASSIS OF THE METER AND THE METAL POLE. ALL BONDS SHOULD BE INTENTIONAL.
- THE NEUTRAL GROUND BOND SHOULD IDEALLY BE AT THE FIRST LOAD CENTERING MEANS AFTER THE ELECTRICAL SERVICE. SEE NEC CODE 250.24 FOR NEUTRAL GROUND BONDING CONNECTION.
- WHEN SITE IS POWERED UP, BEFORE ACCEPTANCE, TEST FOR OBJECTIONABLE CURRENT AND FOREIGN VOLTAGE.

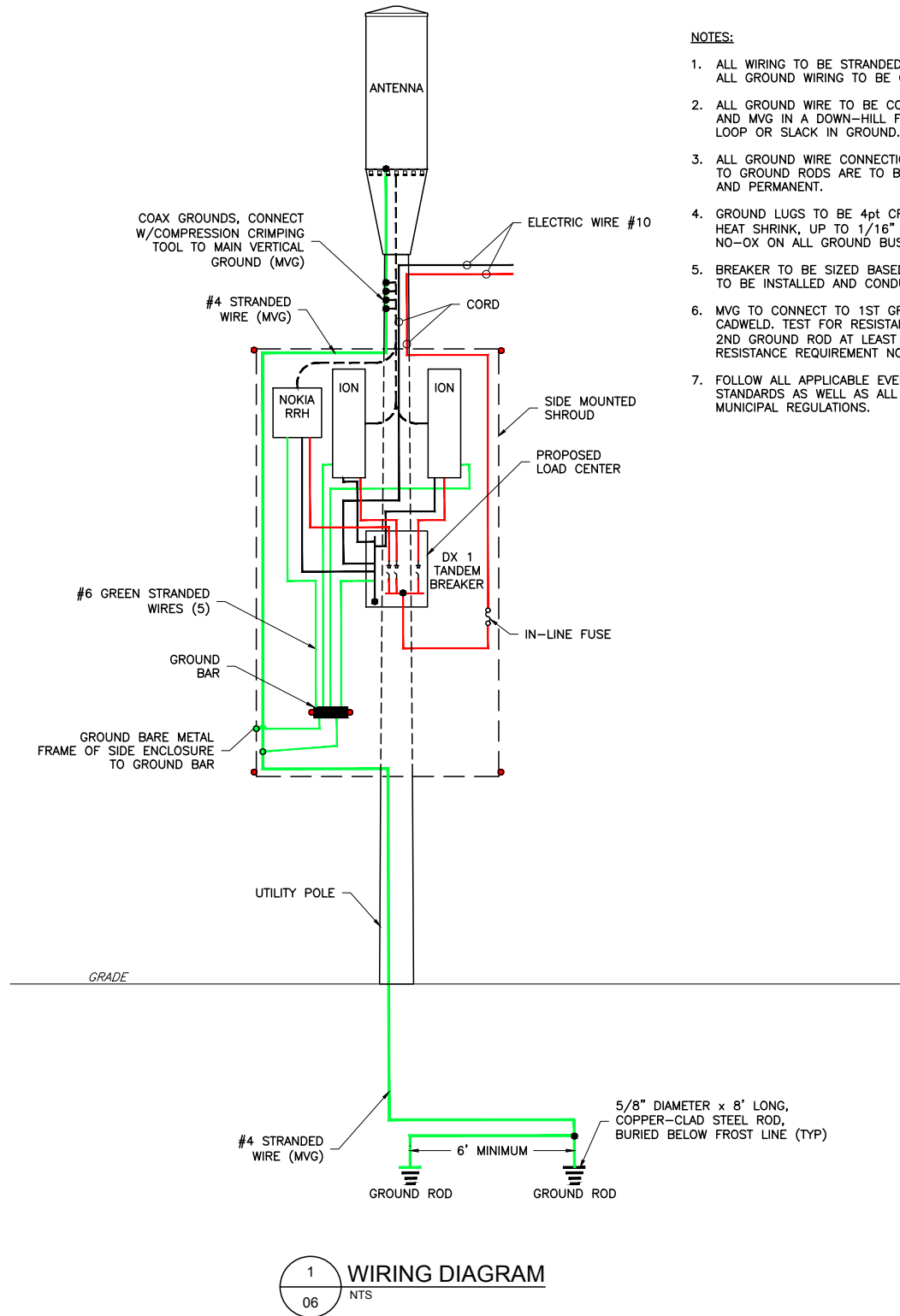

1 WIRING DIAGRAM  
06 NTS

CHARLES INDUSTRIES INC. SHROUD  
PART NO. SHRD60-601  
SHROUD WEIGHT: 110 LBS

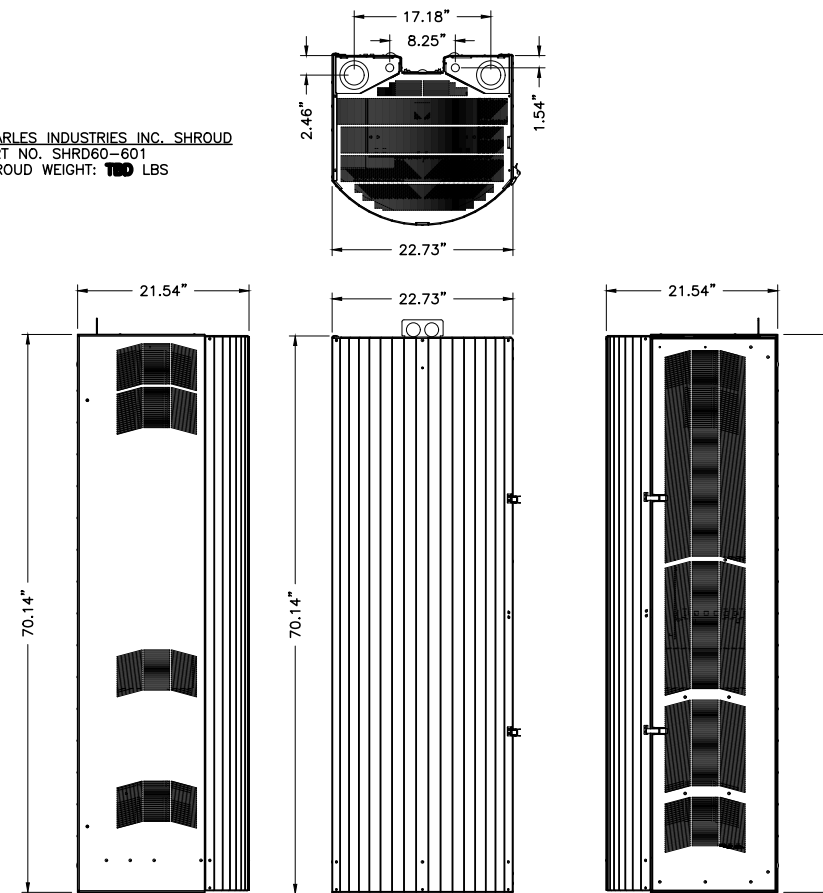

2 SHROUD DETAIL  
06 NTS

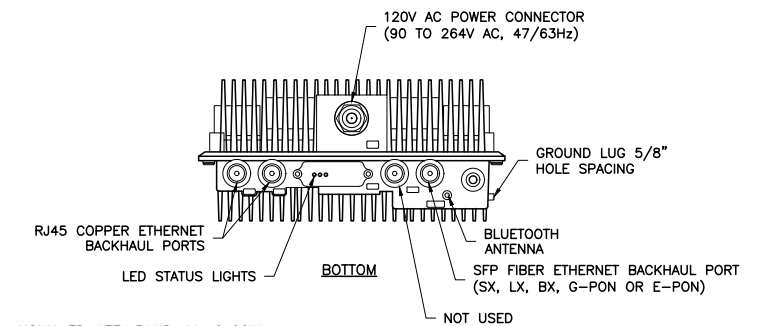

NOKIA TD-LTE, BAND 41, 2x20W  
MINI-MACRO RADIO (FWHR)  
WEIGHT=26.45 LBS

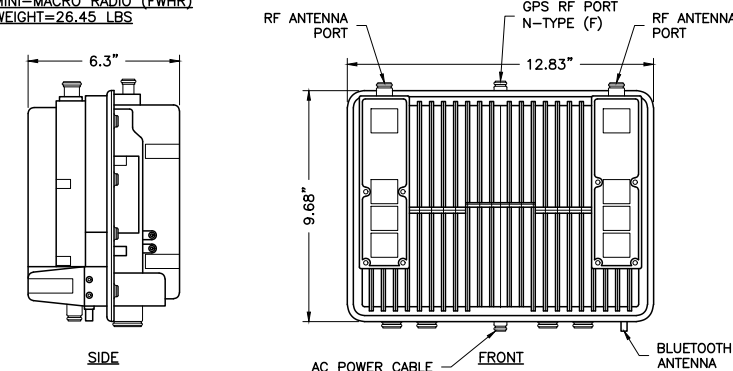

3 NOKIA MINI-MACRO RADIO  
06 NTS

**NOTES:**

- ALL WIRING TO BE STRANDED COPPER THHN; ALL GROUND WIRING TO BE GREEN JACKETED.
- ALL GROUND WIRE TO BE CONNECTED TO MGB AND MVG IN A DOWN-HILL FASHION, NO DRIP LOOP OR SLACK IN GROUND.
- ALL GROUND WIRE CONNECTIONS TO MVG AND TO GROUND RODS ARE TO BE IRREVERSIBLE AND PERMANENT.
- BREAKER TO BE SIZED BASED ON EQUIPMENT TO BE INSTALLED AND CONDUCTOR SIZE.
- MVG TO CONNECT TO 1ST GROUND ROD VIA CADWELD. TEST FOR RESISTANCE AND INSTALL 2ND GROUND ROD AT LEAST 6' FROM 1ST IF RESISTANCE REQUIREMENT NOT MET.
- FOLLOW ALL APPLICABLE EVERSOURCE STANDARDS AS WELL AS ALL APPLICABLE MUNICIPAL REGULATIONS.

ENGINEERING FIRM



APPLICANT



SITE INFORMATION

BS90XSG91  
ODAS\_2D-24 / 406411  
1 BENEDICT STREET  
SOMERVILLE, MA 02145  
MIDDLESEX COUNTY

DESIGN RECORD

REVISIONS			
REV	DATE	DESCRIPTION	BY
1	09/06/19	FINAL	DRG
0	07/27/18	PRELIMINARY	DRG

PROFESSIONAL STAMP



ENGINEER

KRUPAKARAN KOLANDAVILU, P.E.  
MA PROFESSIONAL ENGINEER LIC. #50019

SHEET TITLE

EQUIPMENT  
DETAILS

SHEET NUMBER

SHEET  
06 OF 07

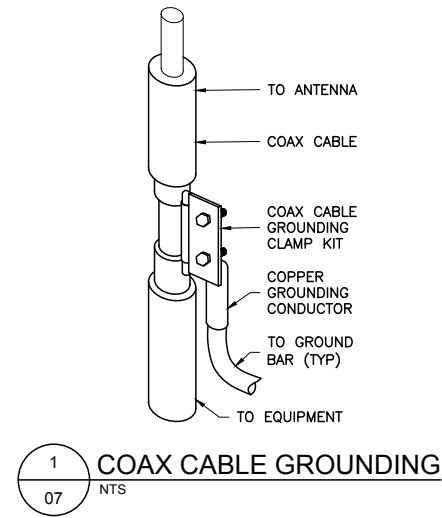

1  
07  
NTS  
COAX CABLE GROUNDING

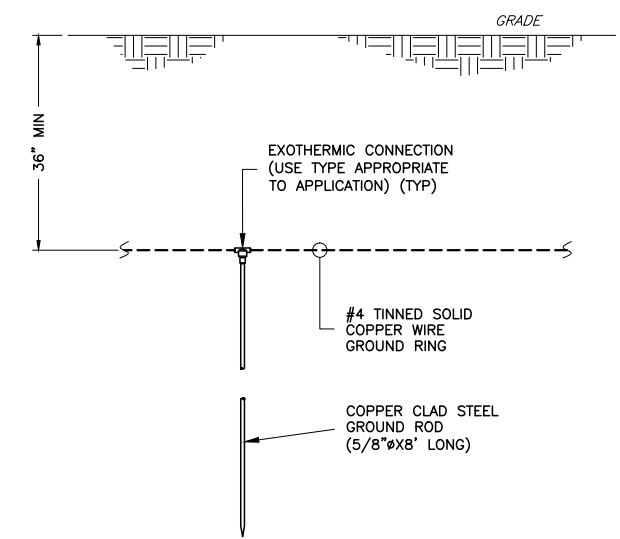

2  
07  
NTS  
TYPICAL GROUND ROD DETAIL

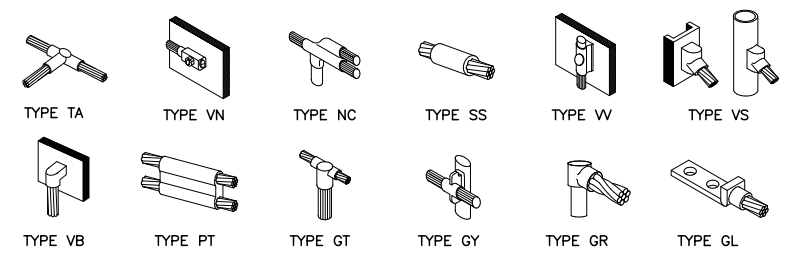

3  
07  
NTS  
GROUNDING CONNECTION DETAILS

ENGINEERING FIRM

**TOTALLY COMMITTED.**

NB+C ENGINEERING SERVICES, LLC.  
100 APOLLO DRIVE, SUITE 303  
CHELMSFORD, MA 01824  
(978) 856-8308

APPLICANT

**CROWN CASTLE**

CROWN CASTLE NG CENTRAL, LLC  
2000 CORPORATE DRIVE  
CANONSBURG, PA 15317  
(713) 570-3000

SITE INFORMATION

BS90XSG91  
ODAS\_2D-24 / 406411  
1 BENEDICT STREET  
SOMERVILLE, MA 02145  
MIDDLESEX COUNTY

DESIGN RECORD

REVISIONS			
REV	DATE	DESCRIPTION	BY
1	09/06/19	FINAL	DRG
0	07/27/18	PRELIMINARY	DRG

PROFESSIONAL STAMP

ENGINEER

KRUPAKARAN KOLANDAIVELU, P.E.  
MA PROFESSIONAL ENGINEER LIC. #50019

SHEET TITLE

**GROUNDING  
DETAILS**

SHEET NUMBER

SHEET  
**07 OF 07**